

Bowen™ Wide Catch Overshot

Instruction Manual 1600

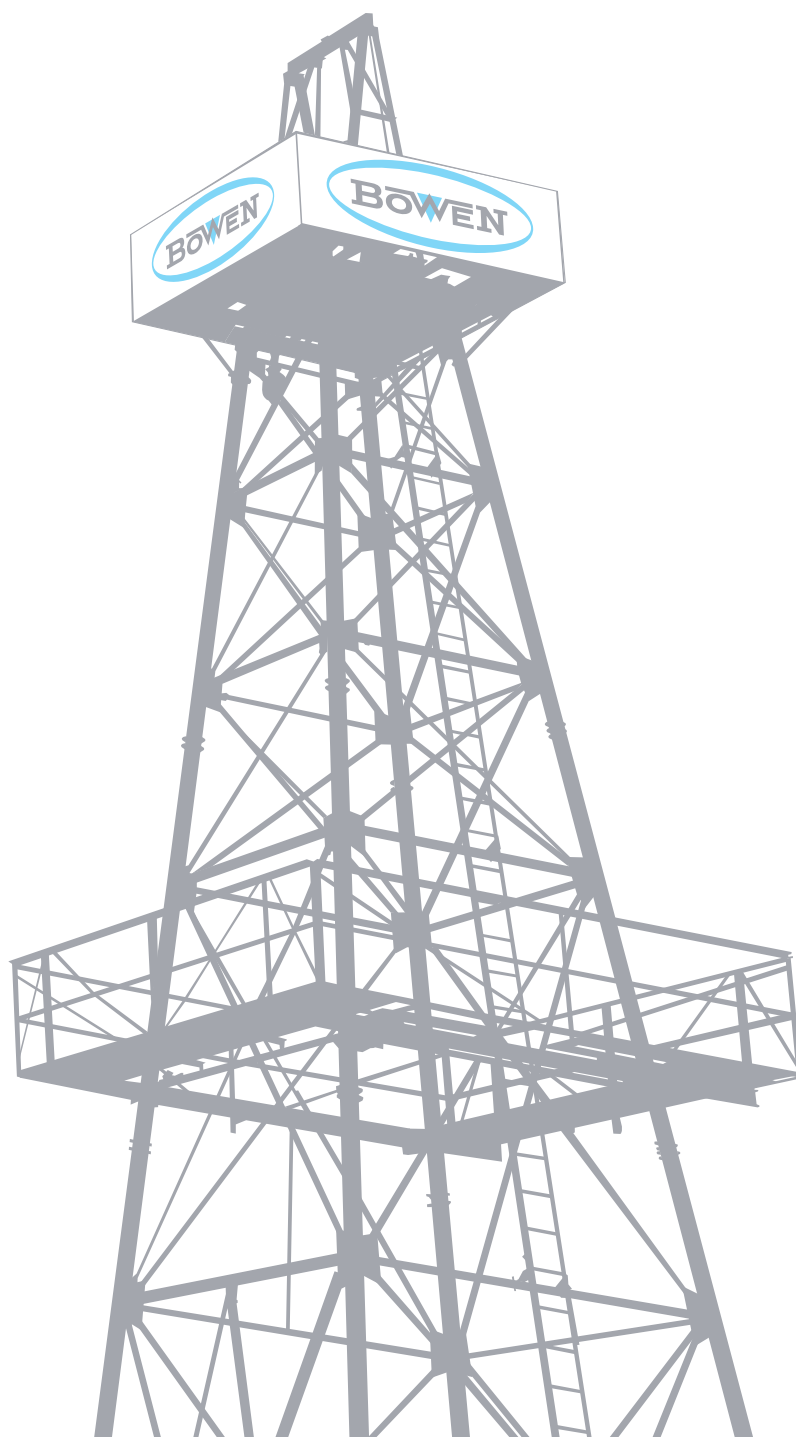

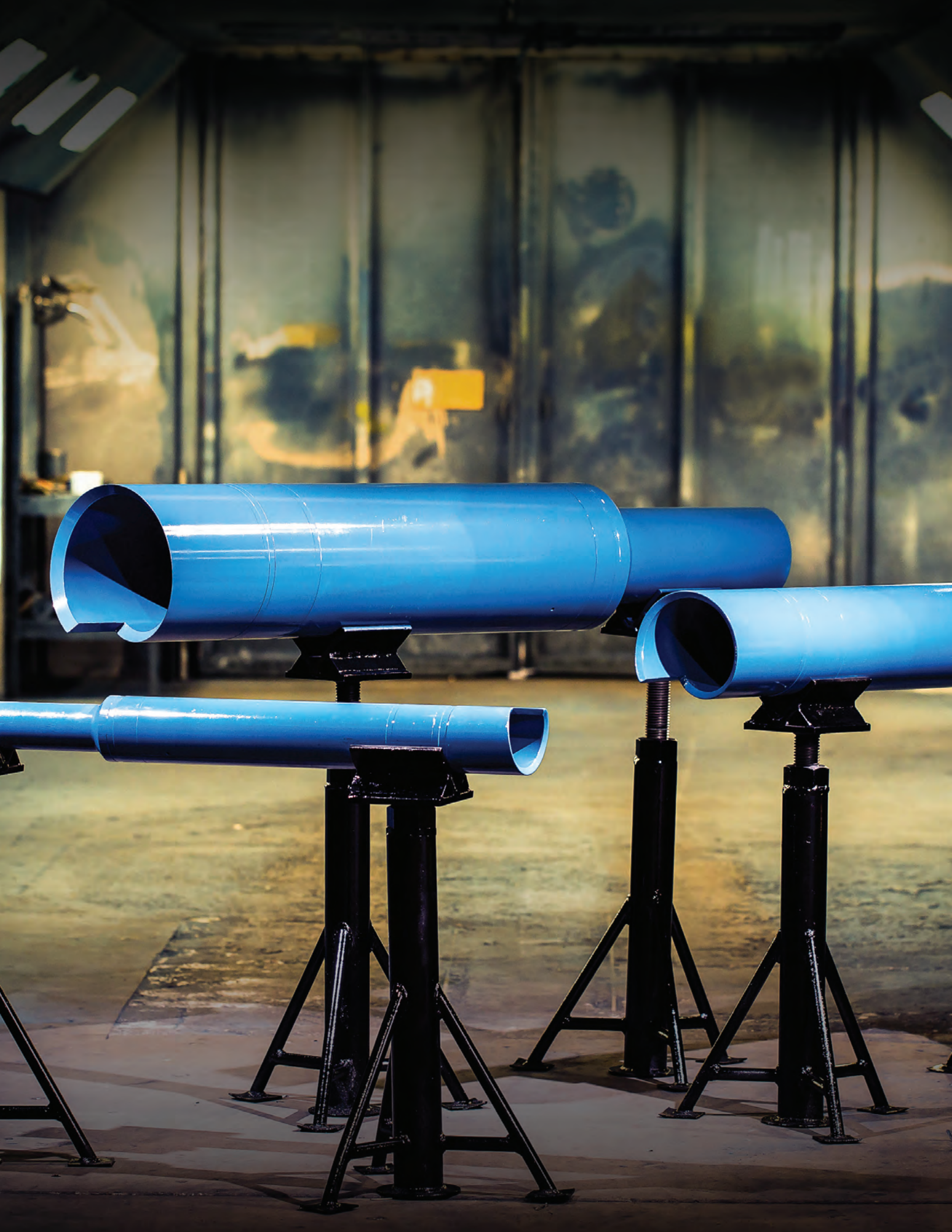

Bowen™ Wide Catch Overshot

Index

General Description	4
Use	4
Construction.....	4
Gripping and Releasing Mechanism	5
Pack-off Mechanism	5
Special Features	6
Assembly	7-11
Operation.....	12-13
Disassembly	14
Parts	16
Specifications and Replacement Parts	17-20
Tool Data	21-22

The designs and specifications for the tools described in this instruction manual were in effect at the time this manual was approved for printing. National Oilwell Varco, whose policy is one of continuous improvement, reserves the right to discontinue models at any time, or to change designs and specifications without notice or without incurring obligation.

Bowen™ Wide Catch Overshot

1. General Description

The Wide Catch overshot offers an extended range that's up to four times greater than any other overshot on the market. It is the most effective tool available to externally engage, pack-off, and pull a fish that has been significantly worn. This rugged tool has the ability to interchange the bottom guide with the full range of existing components used with the standard Bowen™ Series 150 overshot.

In service, the Wide Catch overshot takes a positive grip over a large area of fish and is capable of withstanding heavy pulling, torsional, and jarring strains without causing damage to the tools or the fish. The Wide Catch overshot will allow you to reduce your grapple inventory, decrease your number of trips, and increase your success in fishing, reducing your overall intervention costs.

In addition to the large catch range, the Wide Catch overshot has the ability to seal across very large extrusion gaps at either standard or high pressure and provide full circulation through the fish, should it be required.

Coarse threads at the connection between the top sub and bowl allow for quick assembly while maximizing the torsional and tensile strength.

A seal is created between the connections of the top sub, extension sub, and bowl, which prevents the connection from washing out should the overshot be required to be flowed through for a long period of time. In order to lock the top sub/extension sub to the bowl from backing off during operation, set screws have become standard and will gall the threads should the connection break free.

2. Use

The Wide Catch overshot engages, packs off and retrieves twisted-off, stuck or lost tubing, drill pipe, casing coupling, tool joint, casing or other similar fish.

3. Construction

The standard Wide Catch overshot is composed of three external parts: the top sub, bowl, and guide. You may dress the basic overshot with either of two sets of internal grapple parts, depending

on whether the fish to be caught is near maximum catch size for the particular overshot. You may also assemble the overshot with optional extension subs.

If the fish diameter is near the maximum catch of the overshot, use a spiral grapple, spiral grapple control, and support ring. If the fish diameter is considerably below the maximum catch size (usually ½ in. or more), use a basket grapple and mill control or optional plain control.

The overshot may also be dressed with either of two sets of sealing assemblies depending on the amount of pressure the packers may be subjected to when attempting to circulate fluid. If the operating pressure is low, use the standard pressure assembly consisting of the housing, packer, retainer and O-ring. If you desire a higher operating pressure, use the high pressure assembly consisting of a non-extrusion ring, solid ring, C-ring, housing, packer, retainer, and O-ring.

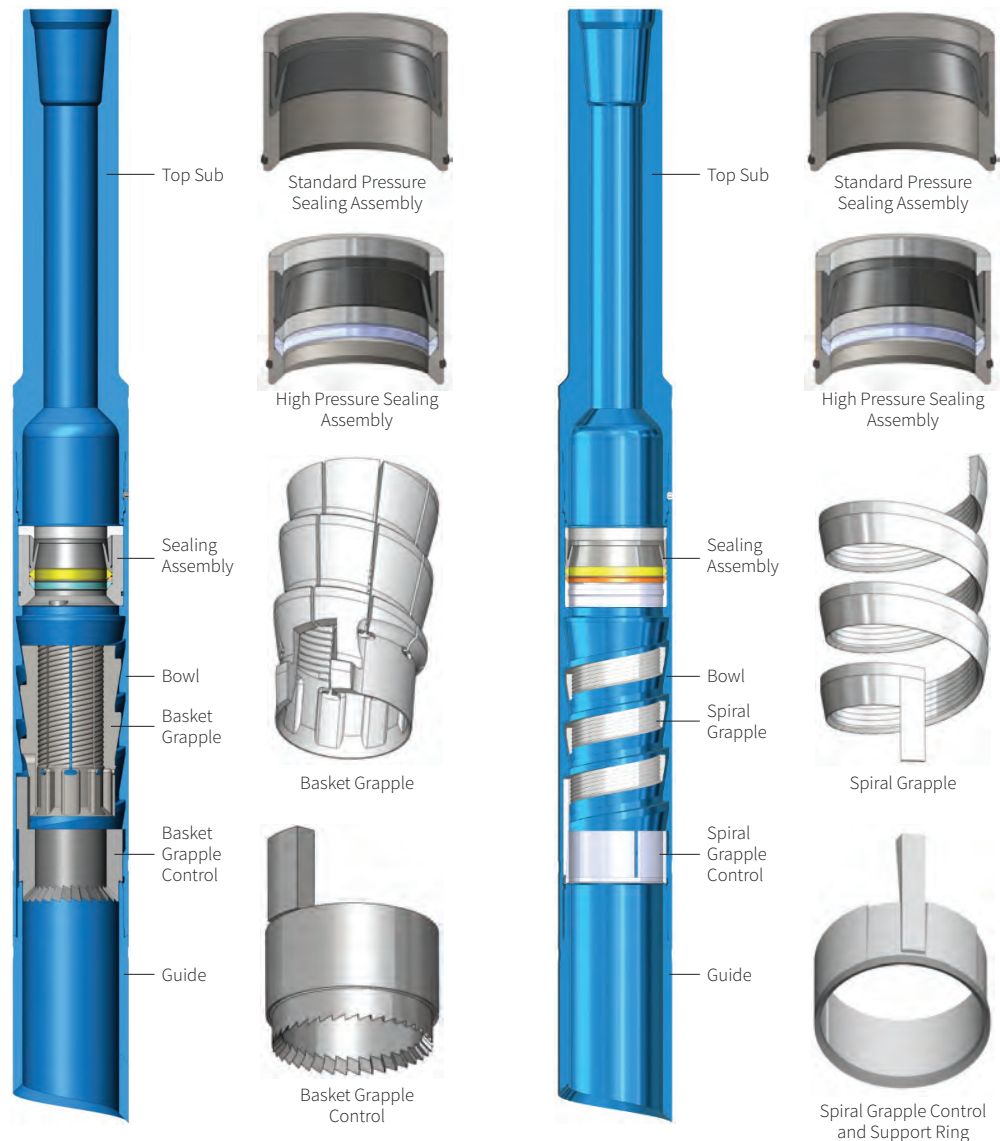

4. Gripping and Releasing Mechanism

The bowl of the overshot has a helically tapered spiral section in its ID. The grapple is threaded into this section of the bowl, as it has a helically tapered spiral on its OD that directly matches the ID of the bowl. When an upward pull is exerted against a fish, an expansion strain spreads evenly over a long section of the fish. The design permits a far stronger tool with a smaller outside diameter than is possible with an overshot that employs a single tapered section which supports slips.

The spiral grapple is formed as a left-hand helix with a tapered exterior to conform with the helically tapered section in the ID of the bowl. A basket grapple is an expandible cylinder with a tapered exterior to conform to the helically tapered section in the bowl. Both have wickered interiors for engagement with the fish.

Grapple controls are used as a special key to allow the grapple to move up and down during operation while simultaneously transmitting full torque from the grapple to the bowl.

There are two types of grapple controls: spiral grapple controls are used with spiral grapples; mill controls are used with basket grapples. (Optional plain basket grapple controls are available upon request.)

Spiral grapple controls are plain, while basket mill controls have hardened teeth on the bottom to allow a light milling operation in order to dress the top of the fish.

During the engagement operation, as the overshot rotates to the right and lowers, the grapple will expand

when the fish is engaged, allowing the fish to enter the grapple. With rotation ceased and upward pull exerted, the grapple contracts by the tapers in the bowl and the wickers grip the fish firmly.

During the releasing operation, a sharp downward bump places the larger portion of the bowl tapers opposite the grapple smaller tapered portion, breaking the hold. Thereafter, when the overshot rotates to the right and slowly elevates, the wickers will unscrew the grapple off the fish, effectively releasing.

The fact that that the Wide Catch overshot requires right-hand rotation only during both the engaging and releasing operations is extremely important. This feature eliminates the dangers that are present when it is necessary to rotate the string to the left.

5. Pack-off Mechanism

The type of pack-off used depends on the amount of pressure on the fish when attempting to pump fluid. If you would like the overshot to seal off with only a minimal pressure applied, use a standard pressure assembly. If your fishing operation requires a high sealing pressure, use the high pressure assembly.

The packer used in the Wide Catch overshot, while similar to a standard Series 150 Type A packer, seals across a large extrusion gap. It includes an outer lip that seals against the ID of the bowl and an inner lip that seals around the OD of the fish. Because each seal packs off a specific size of fish, the cross section of the seal does not change as the nominal size diameter for a specific overshot decreases. As the fish size decreases, the seal housing reduces accordingly.



Standard Pressure Sealing Assembly

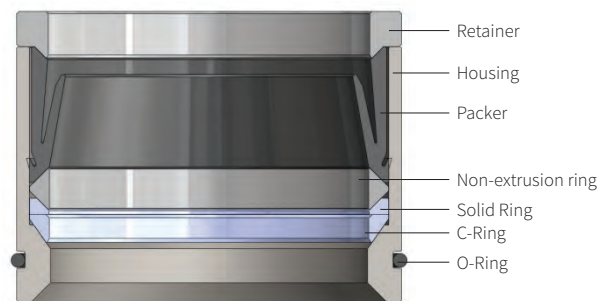

High Pressure Sealing Assembly

Bowen™ Wide Catch Overshot

6. Special Features

You may be concerned that fishing in high profile areas could cause the connection between the top sub and bowl to loosen during engaging and releasing, causing the tool to back off. The Series 150 overshot addresses this concern with a set of lock rings that requires a substantial amount of torque before the connection can be broken. While this is still an option for the Wide Catch overshot, many in the field have requested a more permanent solution. Therefore, the top sub to bowl connection has three equally spaced set screws that are inserted through the threads. In the event that the torque is great enough to break the connection, the threads will be galled by the set screws, preventing the connection from backing off. This feature is included on all bowls, top subs, and extension subs.

Due to the inclusion of the set screw ports on the box connections, with added circulation, the pin connection has been fitted to include an O-ring. This will protect the ports if you do not require the use of set screws and will protect the ports from potential washout. These features are highlighted in the figure.

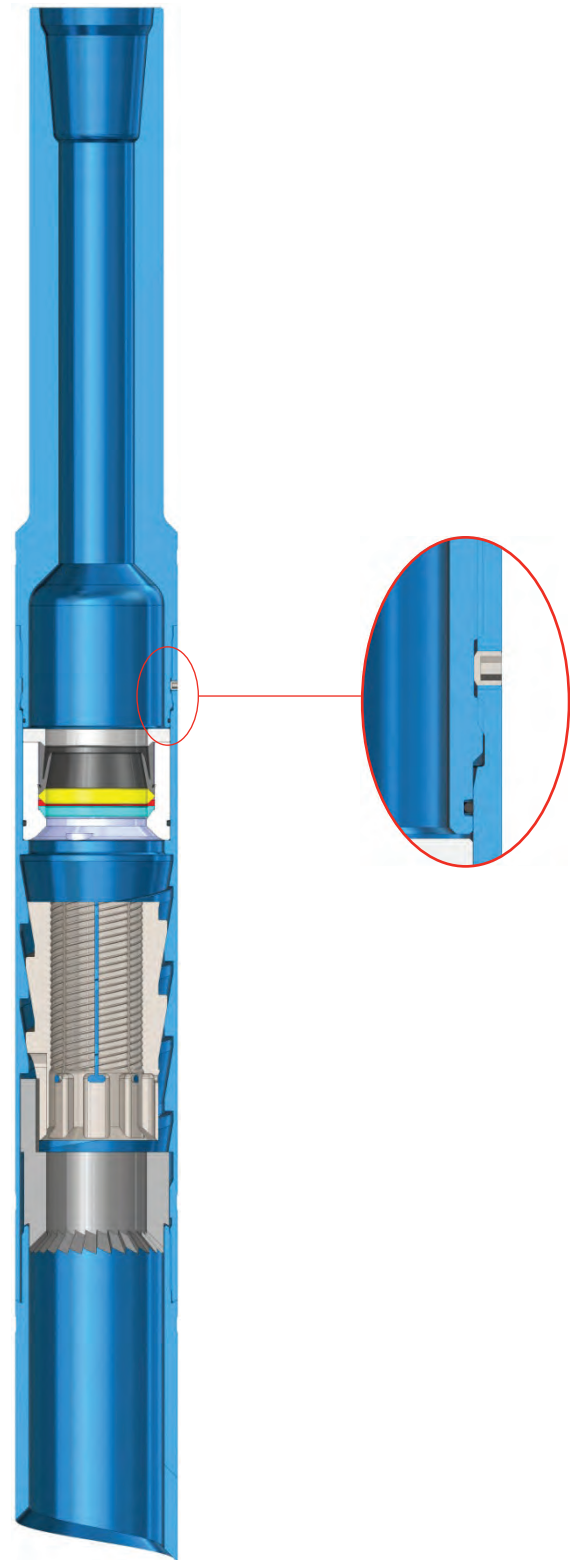

Bowen™ Wide Catch Overshot

7. Assembly

Seal Assembly – Standard Pressure

- For all sizes other than maximum spiral size (e.g., 5¾ in. tool with max spiral grapple size 4¾ in.), a housing is used for the seal assembly. The housings for these sizes are restricted by an insert that holds the seal in place. The seal bore for these sizes are the ID of the bowl.
- Each seal assembly contains an O-ring which is installed into the groove on the OD of the housing.
- **The standard pressure housing has an integral lip that the seal will rest in, seen below.**
- The seal is installed with the small outer lip first into the housing opposite the O-ring groove side. The profile of the seal fits under the machined groove in the housing, which retains the seal.
- The retainer fits against the back of the seal and the face of the housing.
- Both the retainer and the O-ring are interchangeable between the standard and high pressure sealing assemblies.

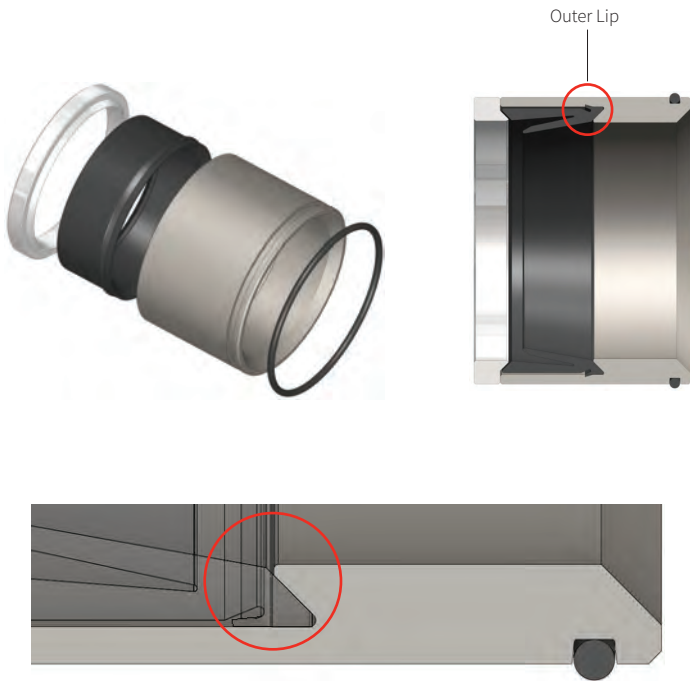

Standard Pressure Housing Includes Integral Lip For Seal

Seal Assembly – High Pressure

- For all sizes other than maximum spiral size (e.g., 5¾ in. tool with max spiral grapple size 4¾ in.), a housing is used for the seal assembly. The housings for these sizes are restricted by an insert that holds the seal in place. The seal bore for these sizes are the ID of the bowl.
- Each seal assembly contains an O-ring which is installed into the groove on the OD of the housing
- **The high pressure housing does NOT have an integral lip that the seal will rest in, seen below. The seal is held in place by the non-extrusion ring.**
- Install the cut C-ring first so that the angle mates with the machined angle inside of the housing.
- Install the solid ring so the larger flat face mates with the face of the C-ring.
- Install the non-extrusion ring, which will mate to the back of the solid ring.
- Install the seal with the small outer lip first into the housing, opposite the O-ring groove side on the housing, with the profile fitting under the angled face of the non-extrusion ring.
- The retainer then fits against the back of the seal and the face of the housing.
- Both the retainer and the O-ring are interchangeable between the standard and high pressure sealing assemblies.

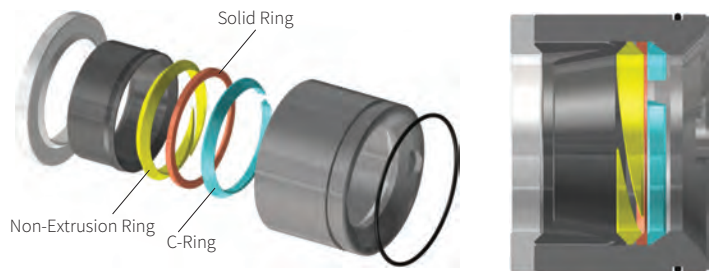

High Pressure Assembly Housing DOES NOT Include the Lip For Seal

Bowen™ Wide Catch Overshot

Installation of the Seal Assembly Into Bowl

- Before inserting the sealing assembly, be sure to secure the bowl in a vice as a certain amount of force may be required to install the sealing assembly.

NOTE: Because of the thin wall section of the bowl, it is best to use the vice over the helical section of the bowl. Placing the vice over the threads or seal area can warp the bowl under excessive force.

- Upon applying a thin layer of grease to the O-ring, the housing slides into the top of the bowl, O-ring side first.
- Press the housing in using a rubber mallet and brass rod or similar tool until it comes into contact with the stop inside the bowl. Take care not to damage any of the internal components of the housing.

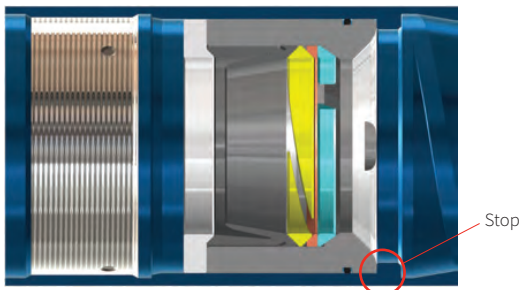
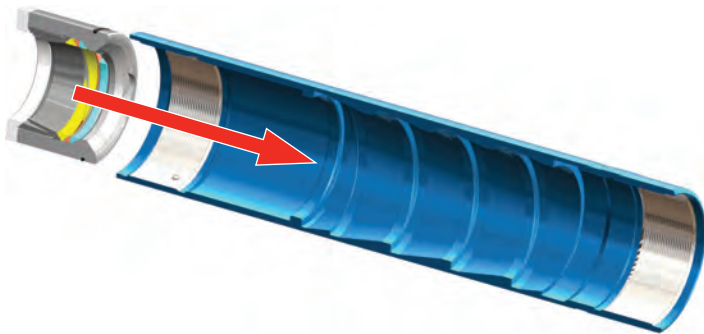

Sealing Assembly Shouldered Against Stop in Bowl

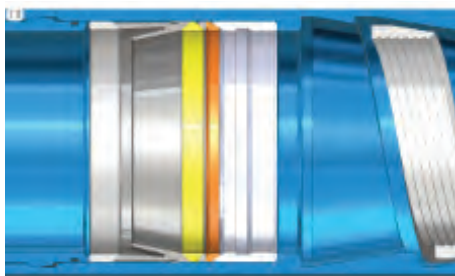

Sealing Assembly Shown for Max Catch Application

Installation of the O-ring on Top Sub/Extension Sub Pin Connection

- The O-ring for the top sub is installed into the groove on the end of the pin connection. A light coating of oil may be used for ease of installation. This O-ring is also used on the pin connection of any extension subs where high circulation is a possibility.

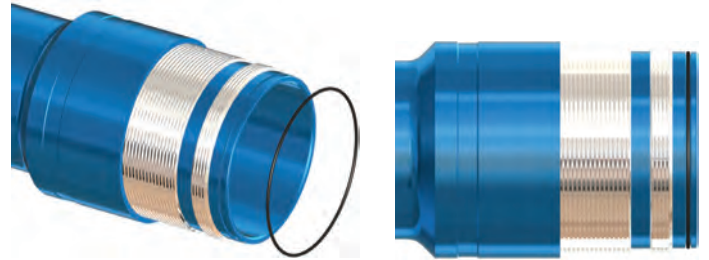

Top Sub/Bowl

- Install the top sub after the sealing assembly. Use right-hand rotation unless otherwise noted.
- Take care to make sure that the retainer ring does not fall over once installed, as this can prevent the top sub from being made up. If this is a concern, place a small amount of grease between the retainer and housing. This will temporarily hold the retainer to the housing and prevent it from falling out of place.
- Once the top sub shoulders up to the bowl, apply the appropriate makeup torque. This value can be found on page 21.



Right-Hand Rotation Required for Top Sub

- Once installed, the top sub will shoulder against the bowl and retain all of the sealing components in place.

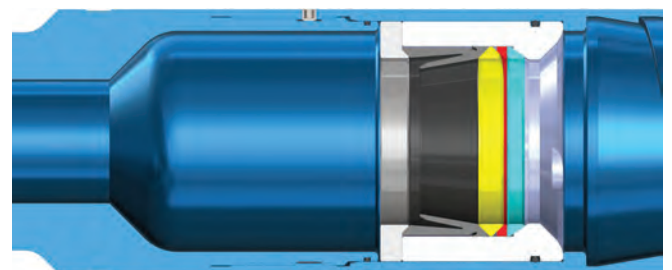

Section View Seal Assembly Retained Between Bowl and Top Sub

Bowen™ Wide Catch Overshot

Installation of Set Screws

- Install three set screws through the threaded ports on the bowl/extension sub box connection. These screws are to be installed until they bottom out against the groove that is machined in the top sub.

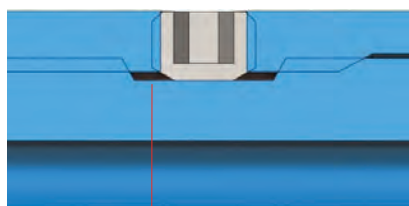
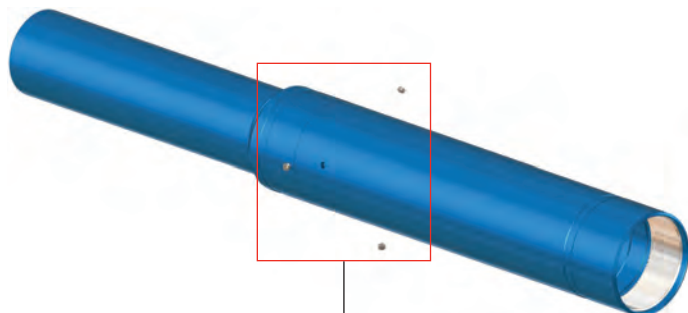

Groove on Top Sub/Extension Sub Pin Thread

Grapple Installation

- Before grapple installation, move the assembly so that the jaws of the vice are positioned on the fishing neck of the top sub. Putting the bowl in the vice may warp it slightly if you tighten the vice too much.
- Install the grapple from the bottom end of the bowl.
- Unless otherwise noted, install both grapples by rotating them to the left.

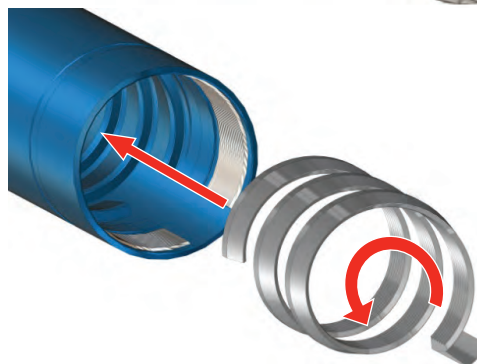
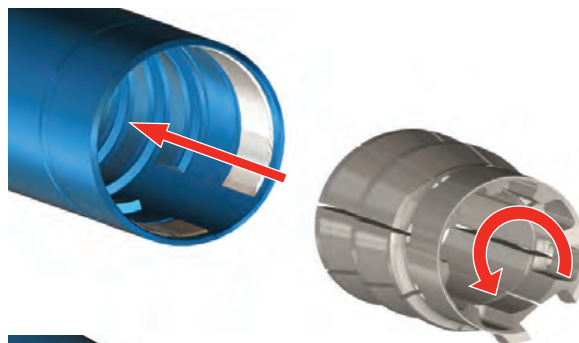

Each standard grapple is assembled with left-hand rotation from the bottom of the bowl

Basket Grapple

- Rotate the grapple in the bowl until the slot in the grapple and bowl line up together.
- The grapple is in the right location when the full helix section on the grapple has shouldered against the helix in the bowl where the machined slot has ended.

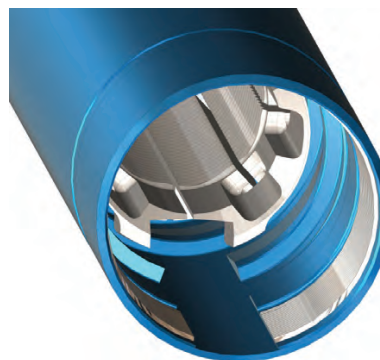

Bowen™ Wide Catch Overshot

Spiral Grapple

- The grapple rotates in the bowl until the tang on the grapple is inserted into the slot in the bowl.
- The grapple is in the correct position when the end of the grapple has shouldered against the portion of the bowl without the machined slot.
- Assembly of the grapple is complete when the tang is pushed to the right, as seen in the picture below.

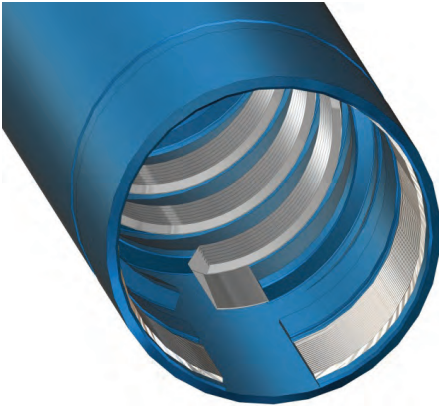

- The finger will fit into the grapple slot, but there should not be interference between the face of the control and the bottom of the grapple.

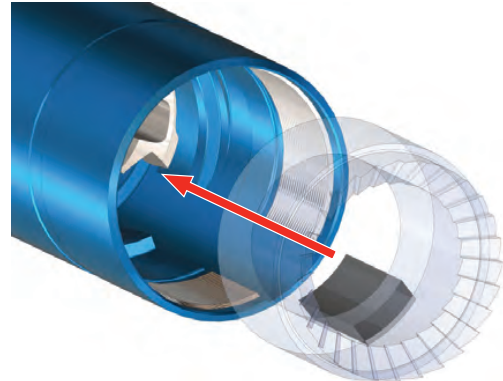

- When the control has been installed correctly, the major OD of the control will not cover the threads. However, the teeth will cover a small portion of the threads.

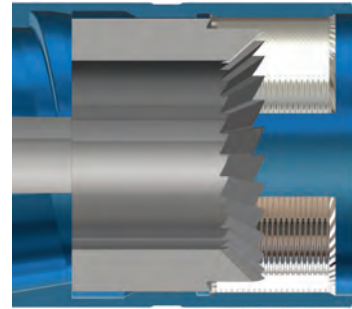

Control Installation

Basket Grapple Control

- The control is oriented so that the protruding finger is inserted first.
- The control finger will follow the bowl slot until it bottoms out against the portion of the bowl where the helix starts. This can be seen on the highlighted portion of the bowl.

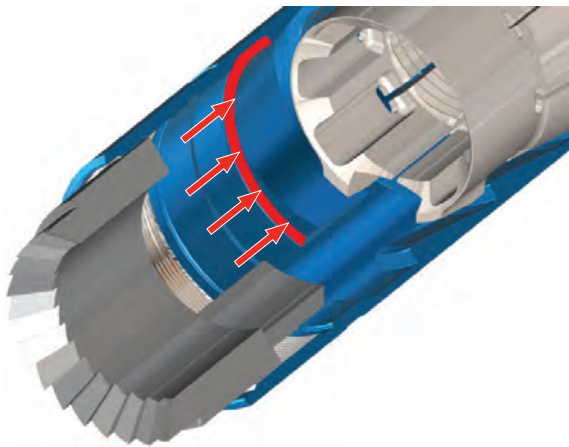

Spiral Grapple Control and Support Ring

- The spiral grapple control is oriented so that the protruding finger is inserted first.
- The finger will follow the bowl slot until it bottoms out against the portion of the bowl where the helix starts.
- As seen in the picture below, the finger on the control will lay to the left of the grapple tang.
- Take care to make sure the tang of the grapple is held in place between the bowl and the control.

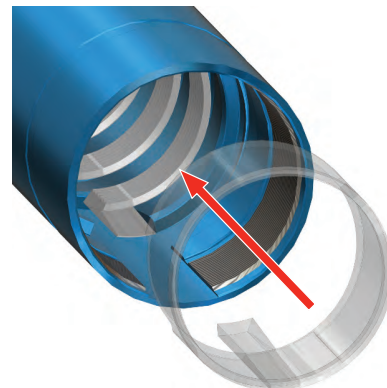

Bowen™ Wide Catch Overshot

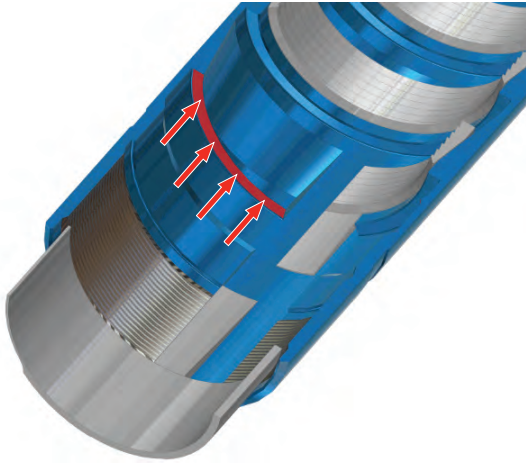

Guide Installation

- The guide is installed once all internal components have been installed.
- Unless otherwise noted, install the guide with right-hand rotation.
- Once the guide shoulders up to the bowl, apply the appropriate makeup torque. This value can be found on page 21.

NOTE: When assembling with a spiral grapple control and support ring, because the ring may shift when the guide is being installed, a small amount of grease may be placed between the support ring and the control. This will stick the support ring to the control and prevent it from falling out of place.

- The flat face of the support ring will shoulder against the bottom flat face of the control.
- A small amount of grease may be placed between the support ring and the control to temporarily hold the support ring to the control and prevent it from falling out of place.
- When the control and support ring have been installed correctly, the major OD of the ring will not cover the threads.

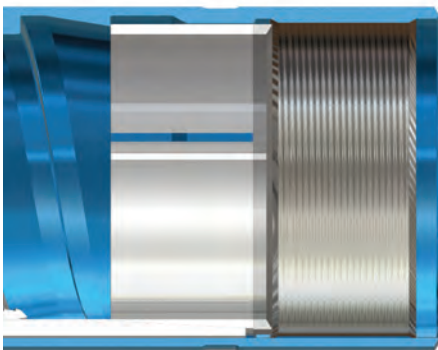
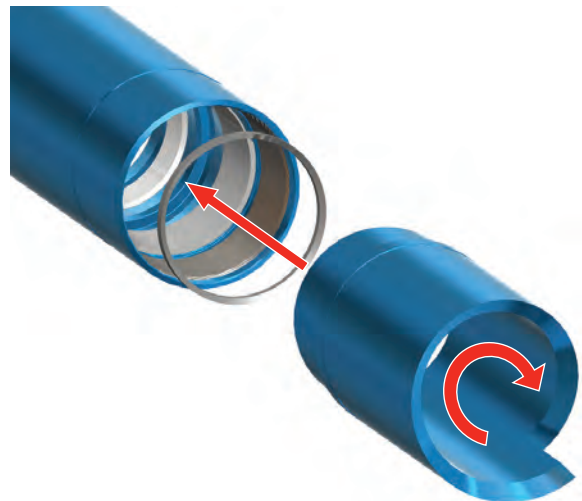
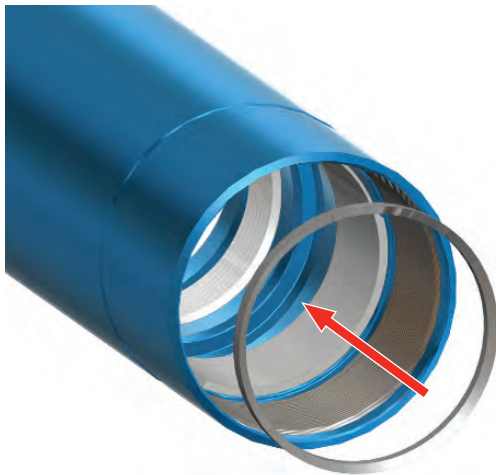
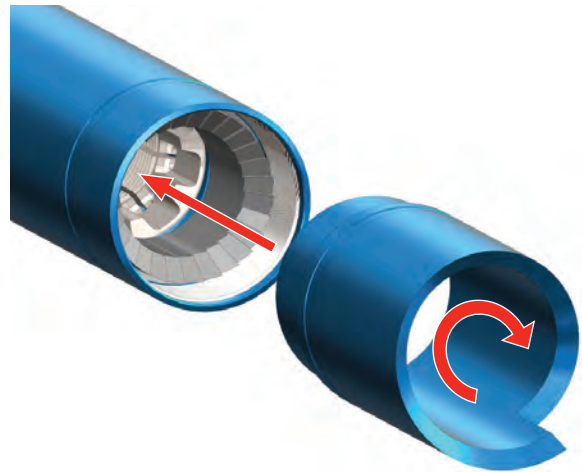

Bowen™ Wide Catch Overshot

- As shown in the pictures below, the guide will fit against the control and hold it in place against the bowl.

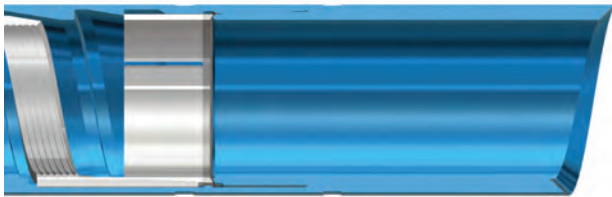
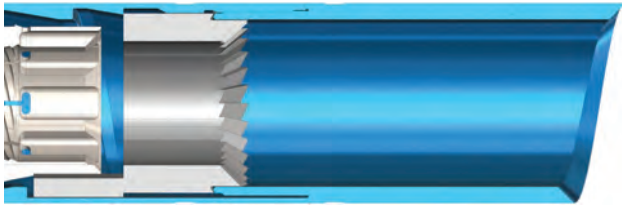

8. Operation

Preliminary Checklist

- First, determine that the overshot is properly assembled, is dressed with the proper size grapple, and that all parts are in good working condition.
- If the fish is smaller than the maximum OD that the overshot was designed to engage, install undersize parts.
- If the hole size is so much greater than the fish size that it is possible for the overshot to pass alongside the fish, install an appropriate wallhook guide or an oversize guide in place of the standard guide. (Note: wallhook guides are typically used only with Lebus knuckle joints.)
- If the top of the fish is a heavily burred tool joint, replace the standard guide with the proper milling guide, type A or C.
- If the fish has an unmanageable upper end, install an extension between the top sub and the bowl.
- Using the top sub, connect the overshot to the fishing string and run it in the hole.

To Engage and Pull the Fish

As the top of the fish is reached, slowly rotate the fishing string to the right and gradually lower the overshot over the fish; combined rotation and lowering is important. Rotating the overshot will allow the grapple to easily centralize the fish and minimize the load required for engagement.

Once the overshot is over the fish, allow the right-hand rotation to slack out of the fishing string and then pull on the fish by elevating the fishing string.

If the fish does not come out, turn on the circulating pumps and maintain an upward strain while circulation is forced through the fish.

NOTE: If jarring operations are required, start with minimal jarring force and gradually increase as required to free the fish. Take care to avoid further damage or tensile failure of the fish itself.

To Release From the Fish

Bump down, then simultaneously rotate to the right and slowly elevate the fishing string until the overshot is clear of the fish; combined rotating and elevating is important.

To release from a recovered fish, follow the same procedure while holding the fish below the overshot.

NOTE: With the conventional Bowen™ Series 150 overshot, when you were unable to release through the standard method of bumping down and rotating to the right, oilfield convention was to disassemble the guide, remove the control, and remove the grapple with the fish still engaged. This procedure is not always possible with the Wide Catch overshot, as the increased catch range does not allow for easy passage of the grapple past the guide threads while still engaged with a fish.

Precautions

- Rotation of the fishing string to the left while the fish is engaged in the overshot is not recommended and should be avoided. Doing so may loosen the connections at the top sub or the bowl.
- Should it be necessary to rotate to the left, maintain an upward

Bowen™ Wide Catch Overshot

strain on the overshot at all times. Without an upward strain, the overshot may lose its ability to bump down to release the fish.

- Always bump the full weight of the fishing string before starting releasing operations.
- Always shut off the circulation pumps before lowering the overshot over the fish.
- Once the fish enters the seal assembly and adequate pressure has been applied, the overshot may be released as noted previously. However, take care not to re-engage the fish once it has disengaged; a second engagement may damage the seal and/or the non-extrusion ring assembly. If a second engagement is necessary, bring the tool to the surface and inspect it for any possible issues before attempting a second run.

Function of the Overshot when Engaging the Fish

After the overshot has reached the top of the fish, combined rotation and lowering results in the following:

1. The guide will direct the fish into the overshot.
2. The control will centralize the fish to align with the grapple.
3. The grapple will expand and the fish will pass through it.
4. The fish will pass through the sealing assembly and will halt when it contacts the shoulder in the top sub pin end.
 - a. In the case where an external upset section is engaged by a basket grapple with a long catch

stop, the fish will halt by the solid steel stop in the upper end of the basket grapple.

- b. Should a separate stop be required, make a stop by using a piece of bar stock that fits into the seal housing bore. This may also be done by using a smaller sized seal housing than the grapple size would require.

5. The fish is now properly located in the overshot and thereafter when an upwards pull is exerted, the grapple contracts by the tapers in the bowl and the hold will be secure.

6. Likewise, once the fish is in this position, the circulation will seal the seal assembly around the fish and prevent fluid passage around the outside of the fish. Thus, by increasing pressure with the pumps, the fluid can be forced down through the fish.

Function of the Overshot when Releasing

The sharp downward bump places the largest portion of the bowl tapers opposite the grapple and breaks the hold. Right-hand rotation expands the grapple, and by maintaining right-hand rotation, you may withdraw the overshot by slowly lifting upward while continually rotating to the right.

Function of the Spiral Grapple

The mechanical conditions which cause the spiral grapple to expand and contract are as follows:

1. The spiral grapple is a left-hand helix.
2. The lower end of the spiral

grapple is anchored in the overshot bowl.

3. The ID of the spiral grapple is smaller than the OD of the fish.

As the overshot rotates to the right and lowers over the fish, the drag of the fish against the spiral grapple causes it to unwind and expand sufficiently to allow the fish to enter.

As the overshot rotates to the right and withdraws from the fish, the drag of the fish against the spiral grapple causes it to unwind and expand sufficiently to allow the overshot to be withdrawn. The wickers that are machined with a left-hand lead allow the grapple to effectively unscrew itself from the fish.

Function of the Basket Grapple

The mechanical conditions which cause the basket grapple to expand and contract are as follows:

1. The basket grapple is machined with a left-hand helix.
2. The lower end of the basket grapple is anchored in the overshot bowl.
3. The inside diameter of the basket grapple is smaller than the outside diameter of the fish.
4. The bottom end of the basket grapple acts as a C-ring.

As the overshot lowers over the fish, the fish pushes against the bottom C-ring of the basket grapple and causes it to expand sufficiently to allow the fish to enter.

As the overshot rotates to the right and withdraws from the fish, the wickers that are machined with a left-hand lead allow the basket grapple to effectively unscrew itself from the fish.

Bowen™ Wide Catch Overshot

9. Disassembly

Guide Disassembly

- Clamp the vice onto the bowl OD across the threads at the top sub connection.
- Remove the guide by applying left-hand rotation. If you applied torque to install the guide, a pipe wrench may be required to loosen the guide.

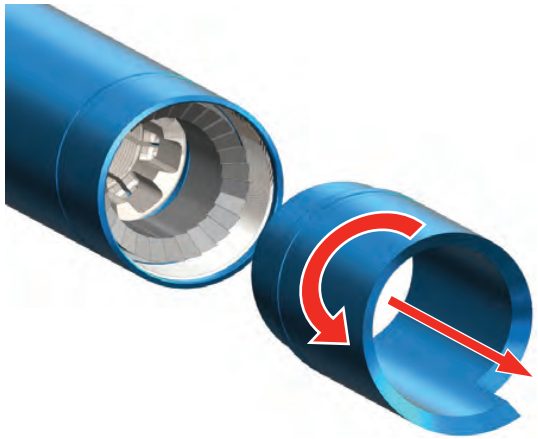

Control Removal

- Remove the control from the bowl after the guide has been removed.

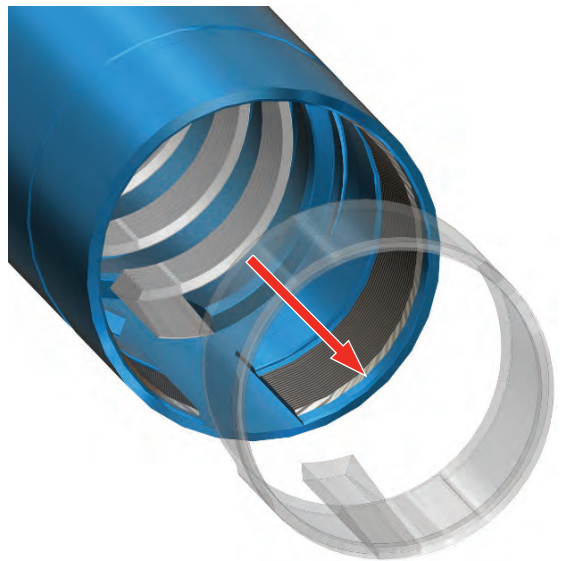
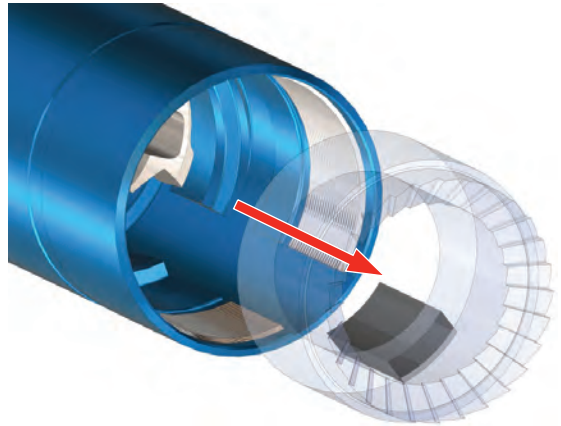

Bowen™ Wide Catch Overshot

Grapple Removal

- Remove the grapple from the bowl using right-hand rotation.

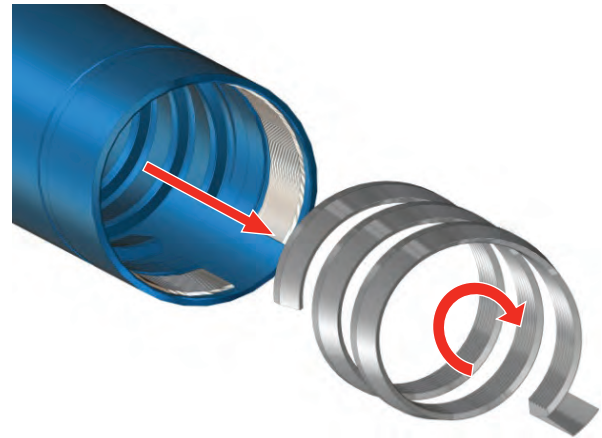
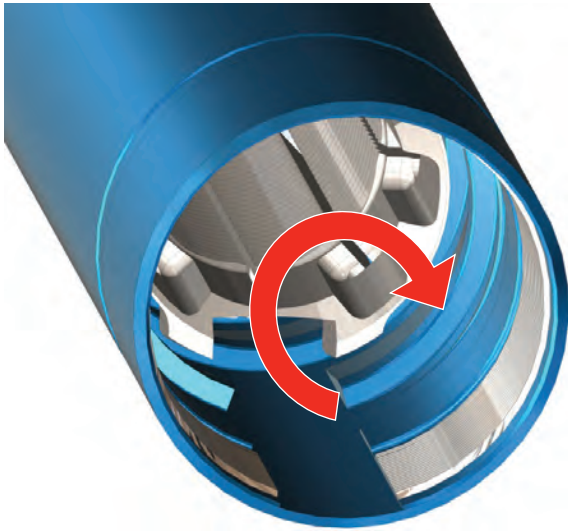

Top Sub Removal

- Remove the set screws before removing the top sub. Failure to do so can result in galled threads and can prevent the top sub from being removed.
- As the bowl and top sub have been torqued together, take care when removing the top sub. Unless otherwise noted, the top sub is removed with left-hand rotation.

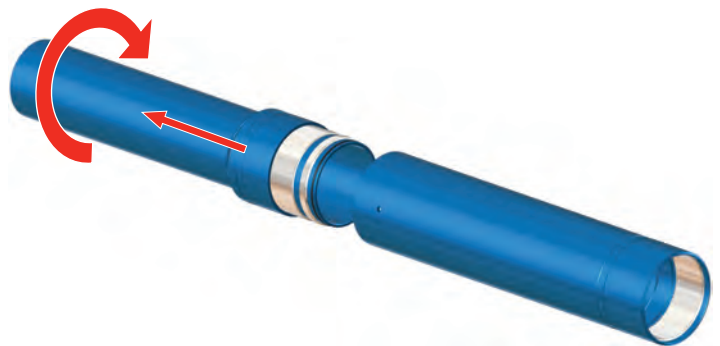
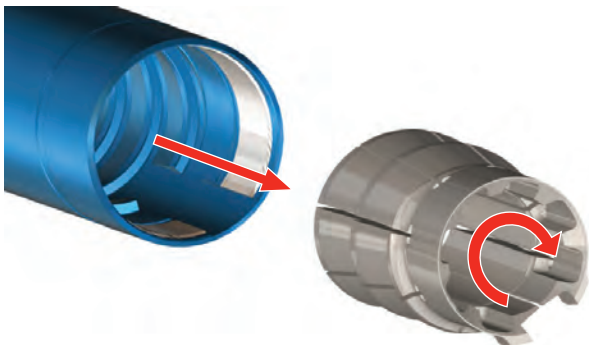
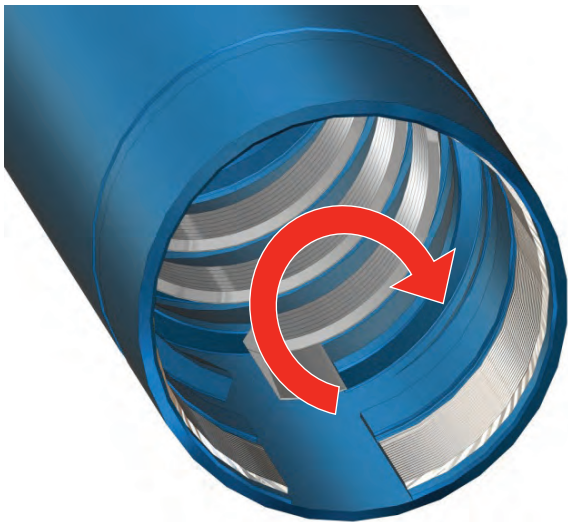

Bowen™ Wide Catch Overshot

Top Sub/Extension Sub O-ring Removal

- Remove the O-ring of the pin thread of the top sub/extension sub using a pick or other tool to pry it out of the groove.

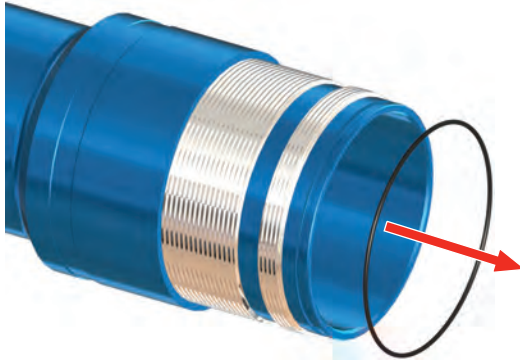

Seal Assembly Removal

- The O-ring groove on the OD of the sealing assembly housing increases the standard squeeze. As a result, you may have to push the housing out from the bottom of the bowl. Small groove shoulders on the housing will aid you in pushing the housing out from the bowl. A rod or similar tool can be used on these faces to push the housing out, if necessary.

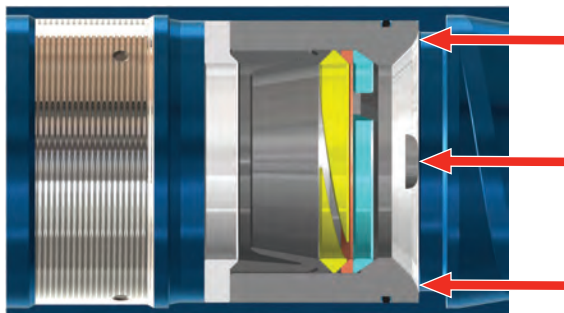
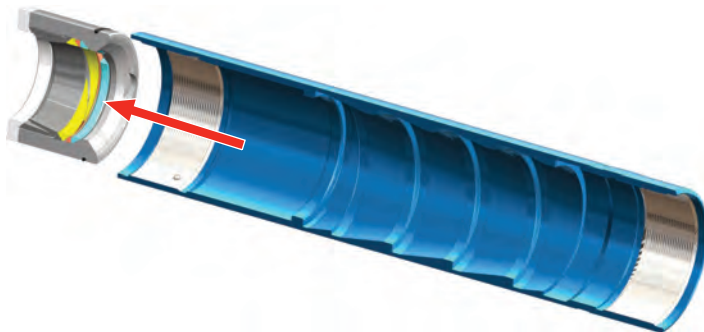

10. Parts

Spiral Parts

Spiral grapples can catch sizes that range from the maximum catch spiral grapple down to maximum catch basket grapple, as listed in the specifications tables.

These spiral grapples and seal assemblies should be changed for each different size fish. They will effectively catch and pack off worn fish that are significantly under the nominal size. The over-range of each grapple is approximately $\frac{1}{32}$ in.

Basket Parts

Basket parts can catch sizes that range from the maximum catch basket grapple, as listed in the specification table, down to any smaller size.

Basket grapples, sealing assemblies, and mill controls should be changed for each size fish to be caught. An optional plain control can be used in place of a mill control if it is deemed unnecessary to dress the top of the fish.

Basket grapples and sealing assemblies effectively catch and pack off worn fish that are significantly under the nominal size. The over-range of each grapple is approximately $\frac{1}{32}$ in.

Sealing Assemblies

All sealing is done above the grapple with the use of a sealing assembly. The assemblies are specific to each catch size but are independent of whether the grapple is a spiral or basket.

Note: once an assembly has been run downhole, it is recommended that the packer (non-extrusion ring, solid ring, C-ring, and O-ring when applicable) be replaced.

Unless there is noticeable damage, the housing and retainer may be reused multiple times.

Extension Subs

If a twist-off has left the upper end of a fish difficult to engage, install an extension sub between the top sub and the bowl of the overshot. This will permit lowering of the overshot over the fish far enough to ensure proper engagement and optimize pack off during the fishing operation.

Guides/ Mill Extensions/ Miscellaneous Bottom Accessories

If the hole size is much greater than the fish size, making it possible for the overshot to pass alongside the fish, install an oversized guide or a wallhook guide in place of the standard guide to ensure alignment of the fish with the overshot.

(Note: wallhook guides are typically used only with knuckle joints.)

The bottom connection is a modified version of the standard Series 150 overshot, such that any existing guides, extensions, and shoes for the same size overshot are interchangeable.

Bowen™ Wide Catch Overshot

11. Specifications and Replacement Parts

Specifications

Maximum Catch Size (Spiral)		3 2½ in.	4 ¾ in.	6 ½ in.	7 in.	8 in.	10 ½ in.
Maximum Catch Size (Basket)		3 ½ in.	4 ⅞ in.	5 ⅞ in.	6 ¼ in.	7 ¼ in.	9 in.
Overshot OD		4 1¼ in.	5 ¾ in.	7 ⅞ in.	8 ⅞ in.	9 ⅞ in.	11 ¾ in.
Standard Box Connection		2 ¾ in. IF Box	3 ½ in. IF Box	3 ½ in. IF Box	4 ½ in. IF Box	4 ½ in. IF Box	6 ¾ in. REG Box
Complete Assembly	Part No.	506586	506366	507460	506458	506585	507331

Replacement Parts

Top Sub	Part No.	506493	506148	507405	506249	506292	507192
	Weight	45 lbs	72 lbs	79 lbs	152 lbs	158 lbs	283 lbs
Bowl	Part No.	506491	506149	507409	506250	506296	507228
	Weight	25 lbs	29 lbs	40 lbs	60 lbs	66 lbs	141 lbs
Spiral Grapple	Part No.	506494	505565	507457	506251	506297	507195
	Weight	5 lbs	6 lbs	9 lbs	8 lbs	23 lbs	23 lbs
Spiral Grapple Control	Part No.	506504	505567	507443	506253	506298	507230
	Weight	1 lbs	2 lbs	3 lbs	4 lbs	5 lbs	10 lbs
Support Ring	Part No.	506661	506662	507456	506659	506660	507456
	Weight	0.1 lbs	0.1 lbs	0.5 lbs	0.1 lbs	0.1 lbs	0.1 lbs
SP Seal Housing	Part No.	See page 18	505578	507411	See page 19	See page 20	-
	Weight	7 lbs	14 lbs	15 lbs	22 lbs	25 lbs	-
Retainer	Part No.	506478	505576	507429	505981	506348	506887
	Weight	1 lbs	1 lbs	0.44 lbs	2 lbs	5 lbs	4 lbs
Packer	Part No.	See page 18	See page 18	507464	See page 19	See page 20	See page 20
	Weight	0.25 lbs	0.25 lbs	0.28 lbs	0.25 lbs	0.25 lbs	0.5 lbs
O-Ring (Housing)	Part No.	See page 18	See page 18	See page 19	See page 19	See page 20	See page 20
	Weight	0.1 lbs	0.1 lbs	0.1 lbs	0.1 lbs	0.1 lbs	0.1 lbs
O-Ring (Top Sub/ Ext Sub)	Part No.	568154	568158	568166	568168	568172	568275
	Weight	0.1 lbs	0.1 lbs	0.1 lbs	0.1 lbs	0.1 lbs	0.1 lbs
Set Screws (Qty. 3)	Part No.	506187/005	506187/005	507415/005	506187/005	506187/005	506187/005
	Weight	0.1 lbs	0.1 lbs	0.1 lbs	0.1 lbs	0.1 lbs	0.1 lbs
Standard Guide	Part No.	6667	6121	507424	9226	A5272	5336
	Weight	13 lbs	23 lbs	38 lbs	40 lbs	45 lbs	88 lbs

Basket Grapple Parts

Basket Grapple	Part No.	506494	505565	-	506251	506297	507195
	Weight	15 lbs	24 lbs	-	35 lbs	35 lbs	57 lbs
Basket Mill Control	Part No.	506502	505568	-	506252	506299	507292
	Weight	5 lbs	5 lbs	-	20 lbs	20 lbs	29 lbs

High Pressure Sealing Assembly

HP Seal Housing	Part No.	See page 18	505903	-	See page 19	See page 20	506883
	Weight	5 lbs	14 lbs	-	22 lbs	25 lbs	4 lbs
Retainer	Part No.	506478	505576	-	505981	506348	506887
	Weight	1 lbs	1 lbs	-	2 lbs	3 lbs	4 lbs
Seals	Part No.	See page 18	See page 18	-	See page 19	See page 20	506888
	Weight	0.25 lbs	0.25 lbs	-	0.25 lbs	0.25 lbs	0.5 lbs
Non-Extrusion Ring	Part No.	See page 18	505904	-	See page 19	See page 20	506886
	Weight	0.25 lbs	0.25 lbs	-	0.25 lbs	0.25 lbs	1.5 lbs
Solid Ring	Part No.	See page 18	505905	-	See page 19	See page 20	506885
	Weight	0.1 lbs	0.1 lbs	-	0.1 lbs	0.1 lbs	0.86 lbs
C-Ring	Part No.	See page 18	505906	-	See page 19	See page 20	506884
	Weight	0.1 lbs	0.1 lbs	-	0.1 lbs	0.1 lbs	1 lbs

Bowen™ Wide Catch Overshot

4 1/16 in. Bowen™ WCOS Seal Kits - Assembly # 506586

Grapple Size	2 3/8 in.	2 3/4 in.	2 7/8 in.	3 1/16 in.	3 1/8 in.	3 1/4 in.	3 1/2 in.	3 23/32 in.
Catch Range	2.406 in.	2.650 in.	2.906 in.	3.094 in.	3.156 in.	3.406 in.	3.531 in.	3.687 in.
(Reference Only)	2.156 in.	2.400 in.	2.656 in.	2.844 in.	2.906 in.	3.156 in.	3.281 in.	3.437 in.

Standard Pressure

Complete Standard Pressure Kit	507273/011	507273/010	507273/009	507273/008	507273/007	507273/006	507273/012	507273/005
---------------------------------------	------------	------------	------------	------------	------------	------------	------------	------------

Standard Pressure Kit Components

SP Housing	506481/011	506481/010	506481/009	506481/008	506481/007	506481/006	506482/005	506481/005
Retainer	506478/012	506478/011	506478/010	506478/009	506478/008	506478/007	506478/006	506478/005
Packer	506479/011	506479/010	506479/009	506479/008	506479/007	506479/006	506480/005	506479/005
O-Ring (Housing)**	568154/020	568154/020	568154/020	568154/020	568154/020	568154/020	568154/020	N/A

High Pressure

Complete High Pressure Kit	507269/011	507269/010	507269/009	507269/008	507269/007	507269/006	507269/012	507269/005
-----------------------------------	------------	------------	------------	------------	------------	------------	------------	------------

High Pressure Kit Components

HP Housing	506483/011	506483/010	506483/009	506483/008	506483/007	506483/006	506484/005	506483/005
Retainer	506478/012	506478/011	506478/010	506478/009	506478/008	506478/007	506478/006	506478/005
Packer	506479/011	506479/010	506479/009	506479/008	506479/007	506479/006	506480/005	506479/005
O-Ring (Housing)**	568154/020	568154/020	568154/020	568154/020	568154/020	568154/020	568154/020	N/A
Solid Backup Ring	506487/011	506487/010	506487/009	506487/008	506487/007	506487/006	506488/005	506487/005
Non-Extrusion Ring	506489/011	506489/010	506489/009	506489/008	506489/007	506489/006	506490/005	506489/005
C-Ring	506485/011	506485/010	506485/009	506485/008	506485/007	506485/006	506486/005	506485/005

**Note - These Parts Can Be Used In Multiple Catch Ranges.

5 3/4 in. Bowen™ WCOS Seal Kits - Assembly # 506366

Grapple Size	2 3/8 in.	2 3/4 in.	2 7/8 in.	3 1/16 in.	3 1/8 in.	3 1/4 in.	4 in.	4 1/8 in.
Catch Range	2.406 in.	2.656 in.	2.906 in.	3.219 in.	3.531 in.	3.781 in.	4.031 in.	4.156 in.
(Reference Only)	2.094 in.	2.344 in.	2.594 in.	2.906 in.	3.219 in.	3.469 in.	3.719 in.	3.843 in.

Standard Pressure

Complete Standard Pressure Kit	507272/009	507272/022	507272/018	507272/021	507272/011	507272/014	507272/012	507272/010
---------------------------------------	------------	------------	------------	------------	------------	------------	------------	------------

Standard Pressure Kit Components

SP Housing	505578/007	505578/022	505578/008	505578/021	505578/013	505578/015	505578/012	505578/011
Retainer	505576/007	505576/022	505576/008	505576/021	505576/012	505576/015	505576/013	505576/011
Packer	505537/006	505537/019	505537/015	505537/018	505537/008	505537/011	505537/009	505537/007
O-Ring (Housing)**	568249/020	568249/020	568249/020	568249/020	568249/020	568249/020	568249/020	568249/020

High Pressure

Complete High Pressure Kit	507268/009	507268/022	507268/018	507268/021	507268/011	507268/014	507268/012	507268/010
-----------------------------------	------------	------------	------------	------------	------------	------------	------------	------------

High Pressure Kit Components

HP Housing	505903/005	505903/009	505903/006	505903/010	505903/007	505903/011	505903/012	505903/013
Retainer	505576/007	505576/022	505576/008	505576/021	505576/012	505576/015	505576/013	505576/011
Packer	505537/006	505537/019	505537/015	505537/018	505537/008	505537/011	505537/009	505537/011
O-Ring (Housing)**	568249/020	568249/020	568249/020	568249/020	568249/020	568249/020	568249/020	568249/020
Solid Backup Ring	505905/005	505905/013	505905/006	505905/014	505905/007	505905/011	505905/010	505905/015
Non-Extrusion Ring	505904/005	505904/013	505904/006	505904/014	505904/007	505904/011	505904/010	505904/015
C-Ring	505906/005	505906/013	505906/006	505906/014	505906/007	505906/011	505906/010	505906/015

Grapple Size	4 1/4 in.	4 7/16 in.	4 1/2 in.	4 3/4 in.
Catch Range	4.281 in.	4.468 in.	4.531 in.	4.781 in.
(Reference Only)	3.969 in.	4.156 in.	4.219 in.	4.469 in.

Standard Pressure

Complete Standard Pressure Kit	507272/008	507272/006	507272/007	507272/005
---------------------------------------	------------	------------	------------	------------

Standard Pressure Kit Components

SP Housing	505578/006	505578/009	505578/010	505578/005
Retainer	505576/006	505576/009	505576/010	505576/005
Packer	505537/005	505536/006	505536/007	505536/005
O-Ring (Housing)**	568249/020	568249/020	568249/020	N/A

High Pressure

Complete High Pressure Kit	507268/008	507268/006	507268/007	507268/005
-----------------------------------	------------	------------	------------	------------

High Pressure Kit Components

HP Housing	505903/014	505903/015	505903/016	505903/017
Retainer	505576/006	505576/009	505576/010	505576/005
Packer	505537/005	505536/006	505536/007	505536/005
O-Ring (Housing)**	568249/020	568249/020	568249/020	N/A
Solid Backup Ring	505905/008	505905/016	505905/017	505905/018
Non-Extrusion Ring	505904/008	505904/016	505904/017	505904/018
C-Ring	505906/008	505906/016	505906/017	505906/018

**Note - These parts can be used in multiple catch ranges.

Bowen™ Wide Catch Overshot

7 3/8 in. Bowen™ WCOS Seal Kits - Assembly # 507460

Grapple Size	5 5/16 in.	6 1/2 in.	6 21/64 in.	6 1/2 in.
Catch Range	6.015 in.	6.188 in.	6.359 in.	6.531 in.
(Reference Only)	5.828 in.	6.000 in.	6.172 in.	6.344 in.

Standard Pressure

Complete Standard Pressure Kit	507442/008	507442/007	507442/006	507442/005
---------------------------------------	------------	------------	------------	------------

Standard Pressure Kit Components

SP Housing	507411/008	507411/007	507411/006	507411/005
Retainer	507429/008	507429/007	507429/006	507429/005
Packer	507464/008	507464/007	507464/006	507464/005
O-Ring (Housing)**	568166/020	568166/020	568166/020	N/A

**Note - These Parts Can Be Used In Multiple Catch Ranges.

8 1/8 in. Bowen™ WCOS Seal Kits - Assembly # 506458

Grapple Size	4 3/8 in.	4 1/2 in.	4 3/4 in.	5 in.	5 1/4 in.	5 1/2 in.	5 3/4 in.	5 7/8 in.
Catch Range	4.406 in.	4.531 in.	4.781 in.	5.031 in.	5.281 in.	5.531 in.	5.781 in.	5.906 in.
(Reference Only)	4.094 in.	4.219 in.	4.469 in.	4.719 in.	4.969 in.	5.219 in.	5.469 in.	5.594 in.

Standard Pressure

Complete Standard Pressure Kit	507271/015	507271/032	507271/010	507271/009	507271/014	507271/013	507271/033	507271/012
---------------------------------------	------------	------------	------------	------------	------------	------------	------------	------------

Standard Pressure Kit Components

SP Housing	505980/021	505980/005	505980/017	505980/014	505980/020	505980/019	505980/006	505980/018
Retainer	505981/022	505981/006	505981/017	505981/014	505981/021	505981/020	505981/008	505981/019
Packer	505979/025	505979/007	505979/013	505979/010	505979/024	505979/023	505979/026	505979/022
O-Ring (Housing)**	568262/020	568262/020	568262/020	568262/020	568262/020	568262/020	568262/020	568262/020

High Pressure

Complete High Pressure Kit	507267/015	507267/031	507267/010	507267/009	507267/014	507267/013	507267/032	507267/012
-----------------------------------	------------	------------	------------	------------	------------	------------	------------	------------

High Pressure Kit Components

HP Housing	506003/021	506003/010	506003/009	506003/008	506003/020	506003/019	506003/011	506003/008
Retainer	505981/022	505981/006	505981/017	505981/014	505981/021	505981/020	505981/008	505981/019
Packer	505979/025	505979/007	505979/013	505979/010	505979/024	505979/023	505979/026	505979/022
O-Ring (Housing)**	568262/020	568262/020	568262/020	568262/020	568262/020	568262/020	568262/020	568262/020
Solid Backup Ring	506005/021	506005/015	506005/009	506005/009	506005/020	506005/019	506005/022	506005/018
Non-Extrusion Ring	506004/021	506004/015	506004/009	506004/008	506004/020	506004/019	506004/022	506004/018
C-Ring	506006/021	506006/015	506006/009	506006/008	506006/020	506006/019	506006/022	506006/018

Grapple Size	6 in.	6 1/4 in.	6 3/8 in.	6 1/2 in.	6 3/4 in.	7 in.
Catch Range	6.031 in.	6.281 in.	6.406 in.	6.531 in.	6.781 in.	7.031 in.
(Reference Only)	5.719 in.	5.969 in.	6.094 in.	6.219 in.	6.469 in.	6.719 in.

Standard Pressure

Complete Standard Pressure Kit	507271/031	507271/008	507271/011	507271/007	507271/006	507271/005
---------------------------------------	------------	------------	------------	------------	------------	------------

Standard Pressure Kit Components

SP Housing	505980/007	505980/010	505980/016	505980/009	506342/005	506342/006
Retainer	505981/011	505981/010	505981/016	505981/009	505981/007	505981/005
Packer	505979/011	505979/006	505979/014	505979/005	505979/021	505978/005
O-Ring (Housing)**	568262/020	568262/020	568262/020	568262/020	568262/020	N/A

High Pressure

Complete High Pressure Kit	507267/033	507267/008	507267/011	507267/007	507267/006	507267/005
-----------------------------------	------------	------------	------------	------------	------------	------------

High Pressure Kit Components

HP Housing	506003/012	506003/007	506003/006	506003/005	506326/005	506326/006
Retainer	505981/011	505981/010	505981/016	505981/009	505981/007	505981/005
Packer	505979/011	505979/006	505979/014	505979/005	505978/007	505978/005
O-Ring (Housing)**	568262/020	568262/020	568262/020	568262/020	568262/020	N/A
Solid Backup Ring	506005/016	506005/007	506005/006	506005/005	506328/005	506328/006
Non-Extrusion Ring	506004/016	506004/007	506004/006	506004/005	506327/005	506327/006
C-Ring	506006/016	506006/007	506006/006	506006/005	506329/005	506329/006

**Note - These parts can be used in multiple catch ranges.

Bowen™ Wide Catch Overshot

9 1/8 in. Bowen™ WCOS Seal Kits - Assembly # 506585

Grapple Size	6 3/4 in.	6 1/2 in.	6 3/4 in.	7 in.	7 1/4 in.	7 1/2 in.	7 3/4 in.	8 in.
Catch Range	6.406 in.	6.531 in.	6.781 in.	7.031 in.	7.281 in.	7.531 in.	7.781 in.	8.031 in.
(Reference Only)	6.094 in.	6.219 in.	6.469 in.	6.719 in.	6.969 in.	7.219 in.	7.469 in.	7.719 in.

Standard Pressure

Complete Standard Pressure Kit	507270/011	507270/007	507270/006	507270/005	507270/035	507270/034	507270/032	507270/031
--------------------------------	------------	------------	------------	------------	------------	------------	------------	------------

Standard Pressure Kit Components

SP Housing	506350/011	506350/010	506350/009	506350/008	506350/006	506350/005	506349/006	506349/005
Retainer	506348/013	506348/012	506348/011	506348/010	506348/008	506348/007	506348/006	506348/005
Packer	505979/014	505979/005	505979/021	505979/020	505979/019	505979/018	505978/008	505978/009
O-Ring (Housing)**	568266/020	568266/020	568266/020	568266/020	568266/020	568266/020	568266/020	N/A

High Pressure

Complete High Pressure Kit	507266/011	507266/007	507266/006	507266/005	507266/035	507266/034	507266/032	507266/031
----------------------------	------------	------------	------------	------------	------------	------------	------------	------------

High Pressure Kit Components

HP Housing	506352/011	506352/010	506352/009	506352/008	506352/006	506352/005	506351/006	506351/005
Retainer	506348/013	506348/012	506348/011	506348/010	506348/008	506348/007	506348/006	506348/005
Packer	505979/014	505979/005	505979/021	505979/020	505979/019	505979/018	505978/008	505978/009
O-Ring (Housing)**	568266/020	568266/020	568266/020	568266/020	568266/020	568266/020	568266/020	N/A
Solid Backup Ring	506005/006	506005/005	506005/014	506005/013	506005/011	506005/010	506328/008	506328/007
Non-Extrusion Ring	506004/006	506004/005	506004/014	506004/013	506004/011	506004/010	506327/008	506327/007
C-Ring	506006/006	506006/005	506006/014	506006/013	506006/011	506006/010	506329/008	506329/007

**Note - These Parts Can Be Used In Multiple Catch Ranges.

11 3/4 in. Bowen™ WCOS Seal Kits - Assembly # 507331

Grapple Size	4-7/8 in.	5-1/4 in.	5-23/32 in.	6-3/16 in.	6-1/4 in.	6-21/32 in.	7-1/8 in.	7-19/32 in.
Catch Range	4.906 in.	5.281 in.	5.750 in.	6.219 in.	6.281 in.	6.688 in.	7.156 in.	7.625 in.
(Reference Only)	4.406 in.	4.781 in.	5.250 in.	5.719 in.	5.781 in.	6.188 in.	6.656 in.	7.125 in.

High Pressure Components

Complete High Pressure Kit	507255/017	507255/019	507255/015	507255/018	507255/013	507255/012	507255/020	507255/016
----------------------------	------------	------------	------------	------------	------------	------------	------------	------------

High Pressure Kit Components

HP Housing	506883/017	506883/019	506883/015	506883/018	506883/013	506883/012	506883/020	506883/016
Retainer	506887/017	506887/019	506887/015	506887/018	506887/013	506887/012	506887/020	506887/016
Packer	506888/017	506888/019	506888/015	506888/018	506888/013	506888/012	506888/020	506888/016
O-Ring (Housing)**	568275/020	568275/020	568275/020	568275/020	568275/020	568275/020	568275/020	568275/020
Solid Backup Ring	506885/017	506885/019	506885/015	506885/018	506885/013	506885/012	506885/020	506885/016
Non-Extrusion Ring	506886/017	506886/019	506886/015	506886/018	506886/013	506886/012	506886/020	506886/016
C-Ring	506884/017	506884/019	506884/015	506884/018	506884/013	506884/012	506884/020	506884/016

Grapple Size	7 3/4 in.	8 1/16 in.	8 17/32 in.	9 in.	9 3/16 in.	9 21/32 in.	10 1/8 in.
Catch Range	7.781 in.	8.093 in.	8.562 in.	9.031 in.	9.219 in.	9.688 in.	10.156 in.
(Reference Only)	7.281 in.	7.593 in.	8.062 in.	8.531 in.	8.719 in.	9.188 in.	9.656 in.

High Pressure

Complete High Pressure Kit	507255/011	507255/014	507255/010	507255/008	507255/007	507255/006	507255/005
----------------------------	------------	------------	------------	------------	------------	------------	------------

High Pressure Kit Components

HP Housing	506883/011	506883/014	506883/010	506883/008	506883/007	506883/006	506883/005
Retainer	506887/011	506887/014	506887/010	506887/008	506887/007	506887/006	506887/005
Packer	506888/011	506888/014	506888/010	506888/008	506888/007	506888/006	506888/005
O-Ring (Housing)**	568275/020	568275/020	568275/020	568275/020	568275/020	568275/020	N/A
Solid Backup Ring	506885/011	506885/014	506885/010	506885/008	506885/007	506885/006	506885/005
Non-Extrusion Ring	506886/011	506886/014	506886/010	506886/008	506886/007	506886/006	506886/005
C-Ring	506884/011	506884/014	506884/010	506884/008	506884/007	506884/006	506884/005

**Note - These parts can be used in multiple catch ranges.

Bowen™ Wide Catch Overshot

Tool Data

Calculated Strengths for the Wide Catch Overshot

Bowl No.	Max Catch Size w/ Spiral Grapple	OD	Load Capacity at Yield Point		Bowl Burst Pressure	Max Seal Operating Pressure	
			Spiral Grapple	Basket Grapple		Standard Assembly ²	High Pressure Assembly ³
506491	3 2 ¹ / ₃₂ in.	4 1 ¹ / ₁₆ in.	332,100 lbs ¹	290,900 lbs ¹	17,800 psi	3,500 psi	10,000 psi
506149	4 3 ¹ / ₄ in.	5 3 ¹ / ₄ in.	407,100 lbs ¹	407,100 lbs ¹	8,000 psi	2,500 psi	6,500 psi
507409	6 1 ¹ / ₂ in.	7 3 ¹ / ₈ in.	435,200 lbs ¹	435,200 lbs ¹	9,200 psi	3,500 psi	-
506250	7 in.	8 1 ¹ / ₈ in.	548,900 lbs ¹	512,300 lbs ¹	10,200 psi	2,200 psi	8,000 psi
506296	8 in.	9 1 ¹ / ₈ in.	548,900 lbs ¹	512,300 lbs ¹	9,000 psi	2,200 psi	7,200 psi
506942	10 1 ¹ / ₈ in.	11 3 ¹ / ₄ in.	969,000 lbs ¹	950,200 lbs ¹	8,200 psi	-	6,600 psi

Calculated Strengths for the Wide Catch Overshot - Reduced OD Specifications

Bowl No.	Max Catch Size w/ Spiral Grapple	OD	Load Capacity at Yield Point		Bowl Burst Pressure	Max Seal Operating Pressure	
			Spiral Grapple	Basket Grapple		Standard Assembly ²	High Pressure Assembly ³
506491	3 2 ¹ / ₃₂ in.	4 1 ¹ / ₁₆ in. to 4 3 ¹ / ₈	300,400 lbs ¹	263,200 lbs ¹	16,000 psi	3,400 psi	9,900 psi

Connection Torque Requirements

OD	Part Numbers			Makeup Torque w/ Bowl	
	Top Sub	Bowl	Guide	Top Sub	Guide
4 1 ¹ / ₁₆ in.	506493	506491	6667	5,200 ft-lbs ⁴	1,100 ft-lbs ⁴
5 3 ¹ / ₄ in.	506148	506149	6121	8,000 ft-lbs ⁴	1,400 ft-lbs ⁴
7 3 ¹ / ₈ in.	507405	507409	507424	13,800 ft-lbs ⁴	4,400 ft-lbs ⁴
8 1 ¹ / ₈ in.	506249	506250	9226	17,800 ft-lbs ⁴	4,200 ft-lbs ⁴
9 1 ¹ / ₈ in.	506292	506296	A5272	22,600 ft-lbs ⁴	6,000 ft-lbs ⁴
11 3 ¹ / ₄ in.	507192	506942	5336	39,600 ft-lbs ⁴	15,100 ft-lbs ⁴

Bowen™ Wide Catch Overshot

Connection Torque Requirements - Reduced OD Specifications

OD in Inches	Part Numbers			Makeup Torque w/ Bowl (ft-lbs) ⁴		
	Top Sub	Bowl	Guide	Top Sub	Guide	Guide
4 1 ¹ / ₁₆ in. to 4 3 ¹ / ₁₆ in.	506493	506491	6667	5,000	1,100	6667

¹ All load capacities listed are calculated theoretical yield points and are considered accurate to within 20%. Note, however, that all strengths assume straight, steady pull and full grapple engagement of a round fish. Anything less than full engagement or straight pulling will reduce the listed strengths substantially. This includes tong marks or other damage to the bowl surface. The above strengths are calculated with a zero pressure differential across the bowl. Should a positive pressure differential occur, there can be a substantial decrease in the allowable pull load due to a pump open effect occurring over the fish. The pressure differential multiplied by the respective top fish area will yield the amount that the operator needs to account for and pull load capacity should be adjusted accordingly. See below for an example:

Example:

- For bowl 506149 (5³/₄ in. Wide Catch overshot) the load capacity is 407,100 lbs.
- Assuming that the fish diameter is 2⁷/₈ in. and an estimated pressure differential of 1000 psi is present, the decrease in load applied is:

$$\begin{aligned} \text{Standard Load Capacity (L}_s\text{)} &= 407,100 \text{ lbs} \\ \text{Fish Diameter (D)} &= 2.875 \text{ in} \\ \text{Pressure Differential (P)} &= 1000 \text{ psi} \\ \pi &= 3.14 \\ \text{Area of Fish (A)} &= \left(\frac{\pi * D^2}{4}\right) = \left(\frac{3.14 * 2.875^2}{4}\right) = 6.49 \text{ in}^2 \end{aligned}$$

$$\begin{aligned} \text{Area of fish(A)*Pressure Differential (P)} &= \text{Decrease in Load Capacity(L}_d\text{)} \\ 6.49 * 1000 &= 6490 \text{ lbs} \end{aligned}$$

$$\begin{aligned} \text{Standard Load Capacity (L}_s\text{)} - \text{Decrease in Load Capacity (L}_d\text{)} &= \text{Max Allowable Load Capacity (L}_m\text{)} \\ 407100 - 6490 &= 400,610 \text{ lbs} \end{aligned}$$

² Standard pressure: The seal operating pressures listed above are for a fish of nominal diameter. As the fish OD decreases, the seal operating pressure reduces. Pressure ratings are given for ambient temperature. As the temperature increases, the ability to maintain a seal diminishes.

³ High pressure: The seal operating pressures listed above are for a fish of nominal diameter. The high pressure assemblies were tested to 250°F and above the published pressure rating. The current limitation is the bowl. Any attempt to maintain a pressure over the published value will increase your risk of bursting the bowl.

⁴ The above torque values are the maximum recommended and set at 50% of the calculated theoretical yield torque. Maximum torque is not required for all fishing jobs and lower torque values will reduce wear and tear to the threads. Torque should be applied evenly to the OD so as to not collapse the OD.



National Oilwell Varco has produced this brochure for general information only, and it is not intended for design purposes. Although every effort has been made to maintain the accuracy and reliability of its content, National Oilwell Varco does not warrant the accuracy or completeness of any data or information contained herein. National Oilwell Varco in no way assumes responsibility for any claim or liability for any loss, damage or injury related to or arising from the use and/or interpretation of the data and information contained herein. The user retains full responsibility for all inferences drawn or decisions made in connection with any such information and data or interpretations of such information and data, and all applications for the material described are at the user's risk and are the user's responsibility.

© 2016 National Oilwell Varco All Rights Reserved
nov.com/patents
10114412-400-ENG-MKT-41/02

Corporate Headquarters
7909 Parkwood Circle Drive
Houston, Texas 77036, USA
Phone: 713 375 3700
Fax: 713 346 7687

For a complete list of NOV Wellbore Technologies locations, visit us online:
nov.com/locations