

1-14 in. Fittings and Accessories

Centricast™ Piping Systems



NOV Fiber Glass Systems offers a complete line of fittings manufactured from both epoxy and vinyl ester resins. These fittings and adhesives provide the same corrosion resistance and temperature ratings as the compatible grade of pipe. Press molded fittings are manufactured from a resin-rich compound which is corrosion resistant throughout the fitting wall. Hand layup fittings have a 100 mil resin-rich corrosion barrier. Epoxy RB fittings are color-coded brown; Z-CORE fittings are dark green or black; CL vinyl ester fittings are off-white. Because the fittings are designed for the most severe services, they are suitable for the broad range of chemicals shown in the **Chemical Resistance Guide**. All 1-14 in. fittings are available with either a socket fitting or flanged type connection for easy field assembly. Adapters to iron pipe threads are also available.

Order by figure (Fig.) number prefixed with CL for vinyl ester, RB for epoxy and ZC for Z-Core followed by construction type (if applicable), diameter, and outlet sizes.

Example: Fig. 34C HLU 3x2

PM - Represents Press Molded Fittings
 HLU - Represents Hand Layup Fittings

Index

Accessories	19
Adhesives	18
Assembled fitting dimensions	14
Centriclump	13
Couplings	3
Crosses	11
Elbows	7
End caps	4
Flanges	6
Floor drains	12
How to read flanged or reducer fittings	17
Laterals	11
Maintenance repair kits	19
Nipples	3
Pipe support/wear pad	12
Pressure ratings	2
Reducers	5
Saddles	4
Special configuration	17
Take off dimensions	17
Tees	10
Threaded adapters	3
Threaded inserts	4

Pressure Ratings

Pressure Rating of CL Vinyl Ester Fittings up to 200°F based on Weldfast™ CL-200 and/or CL-200QS Adhesive Uninsulated Piping

Size (in.)	Elbows, Tees, Reducers Couplings, Flanges, End Caps, Socket and Threaded Nipples		Laterals, Crosses, and Saddles (psi)
	Socket Ftgs. (psi)	Flanged Ftgs. (psi)	
1	200	200	-
1½	200	200	-
2	200	200	125
3	200	200	125
4	150	150	100
6	150	150	100
8	150	150	100
10	150	150	75
12	150	150	75
14	125	150	-

Reduce pressure by 25% for 175°F to 200°F operating temperatures.

Pressure Rating of ZC Epoxy Fittings up to 225°F based on Weldfast ZC-275 Adhesive Uninsulated Piping

Size (in.)	Elbows, Tees, Reducers Couplings, Flanges, End Caps, Socket and Threaded Nipples		Flanges (psi)	Laterals, Crosses, and Saddles (psi)
	Socket Ftgs. (psi)	Flanged Ftgs. (psi)		
1	200	200	300	--
1½	200	200	300	--
2	200	200	300	125
3	200	200	200	125
4	150	150	150	100
6	150	150	150	100
8	150	150	150	100
10	150	150	150	75
12	150	150	150	75
14	125	150	150	--

For insulated and/or heat traced piping systems, use 100% of uninsulated piping recommendations up to 225°F and reduce these ratings 25% for 225°F to 275°F operating temperatures. For uninsulated ZC piping, reduce these ratings 25% for 250°F to 275°F operating temperatures.

Note: Quotations for specially fabricated higher pressure fittings are available on request.

Pressure Rating of RB Epoxy Fittings up to 225°F based on Weldfast ZC-275 Adhesive Uninsulated Piping

Size (in.)	Elbows, Tees, Reducers Couplings, Flanges, End Caps, Socket and Threaded Nipples		Flanges (psi)	Laterals, Crosses, and Saddles (psi)
	Socket Ftgs. (psi)	Flanged Ftgs. (psi)		
1	200	200	300	--
1½	200	200	300	--
2	200	200	300	125
3	200	200	200	125
4	150	150	150	100
6	150	150	150	100
8	150	150	150	100
10	150	150	150	75
12	150	150	150	75
14	125	150	150	--

For insulated and/or heat traced piping systems, use 100% of uninsulated piping recommendations up to 200°F and reduce these ratings 50% for 200°F to 250°F operating temperatures. For uninsulated CENTRICAST PLUS RB-2530 piping, reduce these ratings 30% for 225°F to 250°F operating temperatures.

Couplings

Fig. 14 Socket

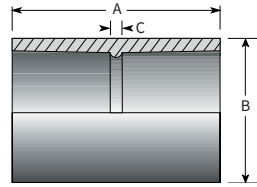

Size (in.)	A ± 1/8 (in.)	B		C Ref (in.)	Wt. † (lb.)
		PM Ref (in.)	HLU Ref (in.)		
1	3	2 1/8	-	5/8	0.5
1 1/2	3	2 3/4	-	3/8	0.5
2	4	3 1/16	-	3/8	0.7
3	4	4 3/16	-	3/8	1.0
4	4	5 1/4	-	3/8	1.5
6	4	8	-	3/8	3.2
8	5 5/8	9 7/8	-	3/8	4.4
10	8 3/8	-	11 3/8	3/8	13.2
12	8 3/8	-	13 1/2	3/8	14.0
14	8 3/8	15 5/16	-	3/8	17.2

Fig. 30 RSR Repair Coupling

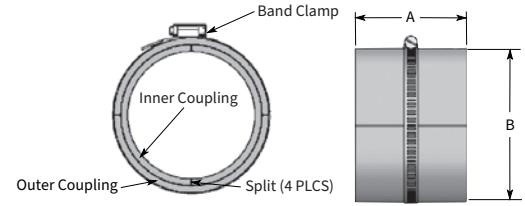

Size (in.)	A ± 1/8 (in.)	B Ref (in.)	Wt. † (lb.)
1	2 5/8	2 3/8	1.0
1 1/2	3 1/4	3	1.0
2	4	3 7/16	1.4
3	4	4 1/16	2.0
4	4	4 1/16	3.0
6	4 3/4	7 11/16	6.5
8	5 1/4	9	8.8
10	5 3/4	11 1/8	26
12	6 1/4	13 1/8	28
14	6 1/4	15 1/8	34

Nipples

Fig. 6S Iron Pipe Male Thread

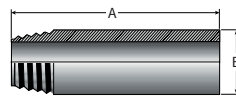

Size (in.)	A ± 1/8 (in.)	B (in.)	Wt. † (lb.)
1	8	1 5/16	0.5
1 1/2	8	1 15/16	0.8
2	8	2 3/8	1.1
3	8	3 1/2	1.9
4	8	4 1/2	2.6
6	8	6 5/8	5.0

Fig. 3S* Iron Pipe

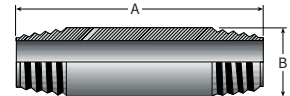

Size (in.)	A ± 1/8 (in.)	B (in.)	Wt. † (lb.)
1	8	1 5/16	0.5
1 1/2	8	1 15/16	0.8
2	8	2 3/8	1.1
3	8	3 1/2	1.9
4	8	4 1/2	2.6
6	8	6 5/8	5.0

Threaded Adapters

Fig. 2 Iron Pipe Thread

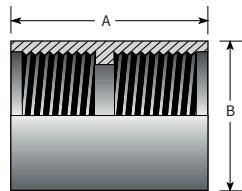

Size (in.)	A ± 3/16 (in.)	B + 0 - 1/16 (in.)	Wt. † (lb.)
1*	3	2 11/16	0.7
1 1/2*	4	3 3/8	0.7
2	3 1/16	3 1/2	1.0
3	4	4 1/2	1.5
4	4 1/2	5 3/4	2.9

Fig. 29S* Iron Pipe Thread x Socket

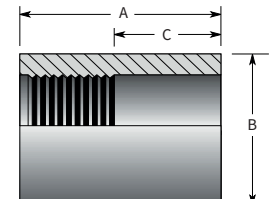

Size (in.)	A + 1/8 - 1/16 (in.)	B ± 1/8 (in.)	C ± 1/16 (in.)	Wt. † (lb.)
2	3 1/16	3 1/2	1 1/2	1.0
3	4	4 1/2	1 13/16	1.4
4	4 1/2	5 3/4	1 13/16	2.8
6	4 1/4	7 1/4	1 13/16	1.6

*Available on order only - nonreturnable. †CL weight, multiply by 1.07 for RB, 1.1 for ZC.

Threaded Insert

Fig. 33S Insert

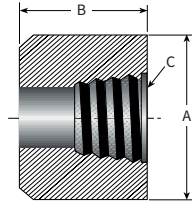

Size (in.)	A Ref (in.)	B ± 1/16 (in.)	C Ref (in.)	Wt. † (lb.)
1 x blank*	1 5/16	1 1/4	-	0.1
1 1/2 x blank*	1 15/16	1 1/2	-	0.2
2 x blank*	2 3/8	1 1/2	-	0.4
3 x blank*	3 1/2	2	-	1.2
2 x 1/4	2 3/8	1 1/2	1/4 I.P.	0.4
2 x 1/2	2 3/8	1 1/2	1/2 I.P.	0.4
2 x 3/4	2 3/8	1 1/2	3/4 I.P.	0.3
2 x 1	2 3/8	1 1/2	1 I.P.	0.3
2 x 1 1/4	2 3/8	1 1/2	1 1/4 I.P.	0.3
2 x 1 1/2	2 3/8	1 1/2	1 1/2 I.P.	0.2
3 x 1	3 1/2	2	1 I.P.	1.0
3 x 1 1/2	3 1/2	2	1 1/2 I.P.	0.8

End Cap

Fig. 101C Socket Pipe Cap

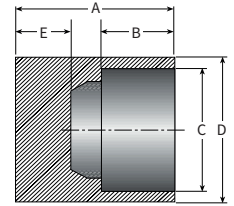

Size (in.)	A ± 3/8 (in.)	B ± 1/16 (in.)	C Ref (in.)	D Ref (in.)	E Ref (in.)	Wt. † (lb.)
1	3 1/16	1 3/16	1 5/16	2 1/16	1 1/4	0.7
1 1/2	3 3/16	1 5/16	1 15/16	2 11/16	1 1/2	0.9
2	4	1 13/16	2 3/8	3 1/8	1 1/2	1.2
3	4	1 13/16	3 1/2	4 3/16	1 1/2	2.2
4	4	1 13/16	4 1/2	5 1/4	1 1/2	3.7
6	4	1 13/16	6 5/8	7 7/8	1 1/2	7.4
8	5 5/8	2 5/8	8 5/8	9 7/8	2 5/8	12.4
10*	8 3/8	4	10 3/4	12 1/4	2	15
12*	8 3/8	4	12 3/4	14 3/16	2	-

Saddle

Fig. 13 Pipe Saddle

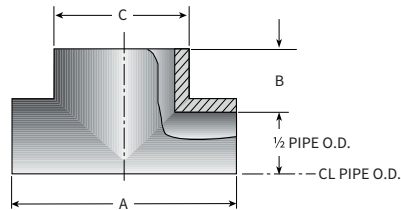

Size (in.)	A ± 1/4 (in.)	B ± 1/16 (in.)	C Ref (in.)							Wt. † (lb.)		
				1	1 1/2	2	3	4	6		8	10
2	4 1/4	3/4	2	X	X							0.4
3	5 3/4	2	3 3/8			X						1.5
4	8	2	4 1/16			X	X					2.6
6	9	2	5 1/8			X		X				4.8
8	10 1/2	2	7 7/16			X			X			8.1
10	13 1/2	3 1/8	10 1/8			X				X		23.1
12	15 1/2	3 1/8	12 3/16			X					X	32.8

Note: For Threaded Outlets or Cement Socket Outlets greater than one size reduction, see Assembled Fittings section.

Figure 13 weights based on blank saddle. Saddles available in CL and RB only.

* Available on order only - nonreturnable

† CL weight, multiply by 1.07 for RB, 1.1 for ZC

Reducers

Fig. 33
Insert Socket

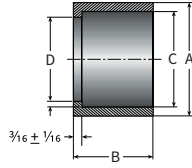

Reducer inserts which reduce greater than two pipe sizes are available on order only. Reducer inserts 8 in. and larger which reduce greater than one pipe size may have a reduced pressure rating. Consult factory for specific recommendations.

Size (in.)	A ± 1/16 (in.)	B ± 1/8 (in.)	C Ref (in.)	D Ref (in.)	Wt. † (lb.)
1½ x 1	1½	1½	1½	1	0.2
2 x 1	2¾	1½	1½	1	0.3
2 x 1½	2¾	1½	1¾	1½	0.2
3 x 1	3½	2	1½	1	0.9
3 x 1½	3½	2	1¾	1½	0.9
3 x 2	3½	2	2¾	2	0.6
4 x 2	4½	2	2¾	2	1.3
4 x 3	4½	2	3½	3	0.7
6 x 2	6¾	2	2¾	2	3.5
6 x 3	6¾	2	3½	3	2.9
6 x 4	6¾	2	4½	4	2.2
8 x 2	8¾	2½	2¾	2	7.4
8 x 3	8¾	2½	3½	3	7.1

Size (in.)	A ± 1/16 (in.)	B ± 1/8 (in.)	C Ref (in.)	D Ref (in.)	Wt. † (lb.)
8 x 4	8¾	2½	4½	4	6.3
8 x 6	8¾	2½	6¾	6½	3.5
10 x 2	10¾	4¾	2¾	2	20.9
10 x 3	10¾	4¾	3½	3	19.9
10 x 4	10¾	4¾	4½	4	17.9
10 x 6	10¾	4¾	6¾	6½	13.8
10 x 8	10¾	4¾	8¾	8½	7.8
12 x 2	12¾	4¾	2¾	2	34.9
12 x 3	12¾	4¾	3½	3	33.1
12 x 4	12¾	4¾	4½	4	29.8
12 x 6	12¾	4¾	6¾	6½	22.9
12 x 8	12¾	4¾	8¾	8½	16.9
12 x 10	12¾	4¾	10¾	10½	12.1

Fig. 34C Concentric Tapered Socket, Hand Layup Construction

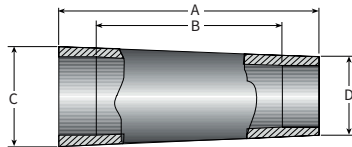

Size (in.)	A Ref (in.)	B ± 3/8 (in.)	C Ref (in.)	D Ref (in.)	Wt. † (lb.)
1½ x 1*	6	3¾	3½	2½	1.6
2 x 1	6	3	3½	2½	2.0
2 x 1½	6	2¾	3½	2½	1.2
3 x 1½	5½	2¾	4¾	3½	2.1
3 x 2	6	2¾	4¾	3½	1.9
4 x 2	7¼	3¾	5¼	3½	2.6
4 x 3	7¼	3¾	5¼	4¾	2.9
6 x 3	9¾	5½	7¾	5¼	6.8
6 x 4	9¾	5¾	7¾	5¼	6.2
8 x 4	15¾	11	9½	5¼	10.7
8 x 6	15¾	11	9½	7½	9.5
10 x 6	13¾	7¾	11½	7½	10.0
10 x 8	14	7¾	11½	9½	11.5
12 x 8	16	9¾	13½	9½	17.2
12 x 10	16¾	9¾	13½	11½	20.7
14 x 12	17¾	9¾	15	13¾	22.8

Fig. 34F⁽¹⁾ Concentric Tapered Socket

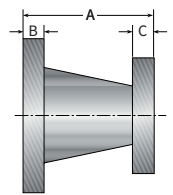

Size (in.)	A Ref (in.)	B ± 1/16 (in.)	C Ref (in.)	Wt. † (lb.)
1½ x 1*	6	1¾	7/8	2.3
2 x 1	6	1¾	7/8	2.8
2 x 1½	6	1¾	1¾	3.4
3 x 1½	6	1¾	1¾	5.1
3 x 2	6	1¾	1¾	5.2
4 x 2	7	1½	1¾	7.5
4 x 3	7	1½	1¾	8.8
6 x 3	9	1¾	1¾	10.1
6 x 4	9	1¾	1½	13.9
8 x 4	11	2¼	1½	18.5
8 x 6	11	2¼	1¾	20.2
10 x 6	12	3¼	1¾	30.4
10 x 8	12	3¼	2¼	35.5
12 x 8	14	3¼	2¼	46.9
12 x 10	14	3¼	3¼	56.3
14 x 12*	25¾	4¾	3¼	93.0

* Available on order only - nonreturnable

(1) See Fig. 18 for flange dimensions.

†CL weight, multiply by 1.07 for RB, 1.1 for ZC

Reducers (continued)

Fig. 35C Eccentric Tapered Socket

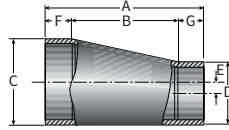

Size (in.)	A Ref (in.)	B ± 3/8 (in.)	C Ref (in.)	D Ref (in.)	E Ref (in.)	F ± 3/8 (in.)	G ± 1/8 (in.)	Wt. † (lb.)
3 x 2	6 5/8	2 15/16	4	2 7/8	1/2	1 13/16	1 3/4	1.3
4 x 2	6 5/8	2 15/16	5	2 7/8	1	1 13/16	1 3/4	1.5
4 x 3	6 5/8	2 15/16	5	4	1/2	1 13/16	1 3/4	1.6
6 x 3	9	5 3/8	7 1/8	4	1 1/2	1 13/16	1 3/4	6.3
6 x 4	9	5 3/8	7 1/8	5	1	1 13/16	1 3/4	5.5
8 x 4	11 13/16	7 3/8	9 1/8	5	2	2 5/8	1 3/4	9.5
8 x 6	11 13/16	7 3/8	9 1/8	7 1/8	1	2 5/8	1 3/4	7.3
10 x 6	13 3/16	7 3/8	11 1/4	7 1/8	2	4	1 3/4	13.7
10 x 8	14	7 3/8	11 1/4	9 1/8	1	4	2 5/8	12.9
12 x 8	16	9 3/8	13 1/4	9 1/8	2	4	2 5/8	16.8
12 x 10	16 3/8	8 3/8	13 1/4	11 1/4	1	4	4	20.0

Fig. 35F⁽¹⁾ Eccentric Tapered Flanged

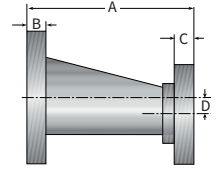

Size (in.)	A ± 1/8 (in.)	B Ref (in.)	C Ref (in.)	D Ref (in.)	Wt. † (lb.)
2 x 1*	6	1 3/16	7/8	1/2	3.4
3 x 2	10 3/4	1 3/16	1 3/16	1/2	6.2
4 x 2	10 3/4	1 1/2	1 3/16	1	8.2
4 x 3	10 3/4	1 1/2	1 3/16	1/2	9.2
6 x 3	9	1 9/16	1 3/16	1 1/2	10.0
6 x 4	9	1 9/16	1 1/2	1	12.0
8 x 4	11	2 1/16	1 1/2	2	16.1
8 x 6	11	2 1/16	1 9/16	1	19.7
10 x 6	12	3 1/16	1 9/16	2	30.9
10 x 8	12	3 1/16	2 1/16	1	35.2
12 x 8	14	3 1/16	2 1/16	2	46.4
12 x 10	14	3 1/16	3 1/16	1	54.8

Flanges

Fig. 18 and Fig. 18L* Flange Socket

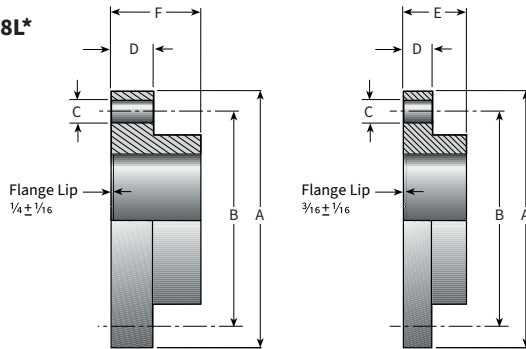

Size (in.)	A Ref (in.)	B Ref (in.)	C Ref (in.)	D ± 1/16 (in.)	E ± 1/16 (in.)	F ± 1/16 (in.)	Wt. † (lb.)	Bolts No/Size
1	4 1/4	3 3/8	5/8	7/8	1 7/16	-	0.6	4-1/2
1 1/2	5	3 7/8	5/8	1 3/16	1 9/16	-	1.1	4-1/2
2	6	4 3/4	3/4	1 3/16	2 1/16	3 1/16	1.6	4-5/8
3	7 1/2	6	3/4	1 3/16	2 1/16	3 1/16	2.5	4-5/8
4	9	7 1/2	3/4	1 1/2	2 1/16	3 5/16	4.2	8-5/8
6	11	9 1/2	7/8	1 9/16	2 1/16	4 7/16	5.3	8-3/4
8	13 1/2	11 3/4	7/8	2 1/16	2 9/16	4 7/16	9.9	8-3/4
10	16	14 1/4	1	3 1/16	4 1/4	-	19.6	12-7/8
12	19	17	1	3 1/16	4 1/4	-	27.8	12-7/8
14	21	18 3/4	1 1/8	4 3/8	4 3/8	-	45.5	12-1

Fig. 18R * Reducer Socket

Size (in.)	A Ref (in.)	B Ref (in.)	C Ref (in.)	D ± 1/16 (in.)	E ± 1/16 (in.)	Wt. † (lb.)	Bolts No/Size
1 1/2 x 1	5	3 7/8	5/8	1 3/16	1 9/16	1.3	4-1/2
2 x 1	6	4 3/4	3/4	1 3/16	2 1/16	1.4	4-5/8
2 x 1 1/2	6	4 3/4	3/4	1 3/16	2 1/16	1.7	4-5/8
3 x 2	7 1/2	6	3/4	1 3/16	2 1/16	3.3	4-5/8
4 x 2	9	7 1/2	3/4	1 1/2	2 1/16	5.4	8-5/8
4 x 3	9	7 1/2	3/4	1 1/2	2 1/16	4.9	8-5/8
6 x 2	11	9 1/2	7/8	1 9/16	2 1/16	7.6	8-3/4
6 x 3	11	9 1/2	7/8	1 9/16	2 1/16	8.0	8-3/4
6 x 4	11	9 1/2	7/8	1 9/16	2 1/16	8.8	8-3/4
8 x 2	13 1/2	11 3/4	7/8	2 1/16	2 9/16	17.6	8-3/4
8 x 3	13 1/2	11 3/4	7/8	2 1/16	2 9/16	17.0	8-3/4
8 x 4	13 1/2	11 3/4	7/8	2 1/16	2 9/16	16.0	8-3/4
8 x 6	13 1/2	11 3/4	7/8	2 1/16	2 9/16	13.4	8-3/4
10 x 6	16	14 1/4	1	3 1/16	4 1/4	33.4	12-7/8
10 x 8	16	14 1/4	1	3 1/16	4 1/4	27.3	12-7/8
12 x 8	16	17	1	3 1/16	4 1/4	49.9	12-7/8
12 x 10	16	17	1	3 1/16	4 1/4	43.3	12-7/8

Flanges meet O.D. bolt circle diameter, number of holes, and bolt hole diameter dimensions for ANSI B16.1 125 lb. cast iron sizes 1-72 in. and ANSI B16.5 lb. steel for 1 in.-24 in. diameters.

* Available on order only - nonreturnable

(1) See Fig. 18 for flange dimensions.

† CL weight, multiply by 1.07 for RB, 1.1 for ZC

Flanges (continued)

Fig. 18M* Flange Metric Socket

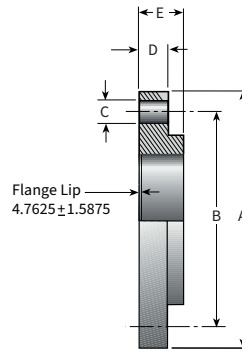
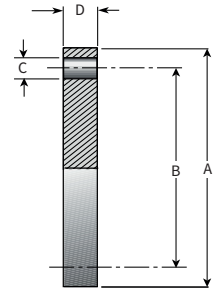

Fig. 22 Blind Flange



Size (mm)	A Ref (in.)	B Ref (mm)	C Ref (mm)	D ± 1.588 (mm)	E ± 1.588 (mm)	Bolts No/Size	
25	1	115	85	14	22.225	34.925	4-12 mm
40	1½	150	110	18	30.163	38.100	4-16 mm
50	2	165	125	18	30.163	50.800	4-16 mm
80	3	200	160	18	30.163	50.800	8-16 mm
100	4	220	180	18	38.100	50.800	8-16 mm
150	6	279	241	23	39.100	50.800	8-20 mm
200	8	343	298	23	52.388	60.325	8-20 mm
250	10	406	350	23	77.788	106.363	12-20 mm
300	12	483	400	23	77.788	106.363	12-20 mm

Fig 22S⁽²⁾ Iron Pipe Tapped

Size (in.)	A ± 1/8 (in.)	B ± 1/16 (in.)	C Ref (in.)	D ± 1/16 (in.)	Wt. † (lb.)	Bolts No/Size
1	4¼	3½	5/8	7/8	0.6	4-1½
1½	5	3¾	5/8	1¾	1.2	4-1½
2	6	4¾	¾	1¾	1.8	4-5/8
3	7½	6	¾	1¾	3.0	4-5/8
4	9	7½	¾	1½	5.2	8-5/8
6	11	9½	7/8	1¾	8.2	8-¾
8	13½	11¾	7/8	2¼	16.6	8-¾
10	16	14¼	1	3¼	34.3	12-7/8
12	19	17	1	3¼	49.1	12-7/8

Fig. 21/24/25* Van Stone Flange

Size (in.)	A Ref (in.)	B Ref (in.)	C Ref (in.)	D ± 1/16 (in.)	E ± 1/16 (in.)	F	
						Fiberglass Ring ± 1/16	Steel Ring ± 1/8
2	6	4¾	¾	1	2	7/8	5/8
3	7½	6	¾	1	2	7/8	5/8
4	9	7½	¾	1	2	7/8	5/8
6	11	9½	7/8	1	2	7/8	¾

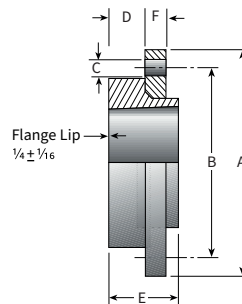

Elbows

Fig. 255C 90° Short Radius Elbow, Socket

Size (in.)	A ± 1/16 (in.)	B ± 1/16 (in.)	Wt. † (lb.)
1	2½	1¾	0.4
1½	2¾	1¾	0.6
2	3¾	1¾	1.5
3	4¾	1¾	2.4
4	5¾	1¾	3.5
6	6	1¾	7.6
8	7½	2½	12.0

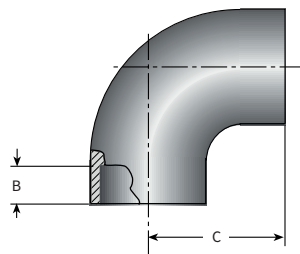

Sizes 1 in. - 6 in. PM Construction

8 in. HLU Construction

* Available on order only - nonreturnable

(2) Maximum Iron Pipe Thread size = 1 in.

† CL weight, multiply by 1.07 for RB, 1.1 for ZC

Fig. 257C 90° Long Radius Elbow, Socket

Size (in.)	A ± 3/16 (in.)	B ± 1/8 (in.)	Wt. † (lb.)
1	5	1¾	1.0
1½	6	1¾	1.5
2	6½	1¾	1.9
3	7¾	1¾	2.2
4	9	1¾	3.6
6	10¾	1¾	7.6
8	14¾	2½	13.8
10	17¼	4	22.8
12	20¾	4	31.4
14	22	4	41.0

HLU Construction

Elbows (Continued)

Fig. 255S* 90° Short Radius Elbow, Flange x Socket

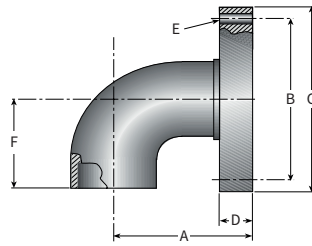

Size (in)	A ±1/16 (in.)	B Ref (in.)	C Ref (in.)	D Ref (in.)	E Ref (in.)	F Ref (in.)	Wt. † (lb.)	Bolts No/Size
1	3 1/16	3 3/8	4 1/4	7/8	5/8	2 1/2	1.1	4-1/2
1 1/2	4 5/16	3 7/8	5	1 3/16	5/8	2 3/4	1.9	4-1/2
2	5 7/8	4 3/4	6	1 3/16	3/4	3 1/16	3.3	4-5/8
3	6 1/2	6	7 1/2	1 3/16	3/4	4 7/16	5.1	4-5/8
4	7 1/8	7 1/2	9	1 1/2	3/4	5 1/16	8.3	8-5/8
6	8 1/16	9 1/2	11	1 9/16	7/8	6	14.2	8-3/4
8	10 1/16	11 3/4	13 1/2	2 1/16	7/8	7 1/2	25	8-3/4

Fig. 255F 90° Short Radius Elbow, Flanged

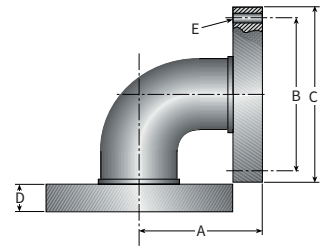

Size (in)	A ±1/16 (in.)	B Ref (in.)	C Ref (in.)	D Ref (in.)	E Ref (in.)	Wt. † (lb.)	Bolts No/Size
1	3 1/16	3 3/8	4 1/4	7/8	5/8	1.8	4-1/2
1 1/2	4 13/16	3 7/8	5	1 3/16	5/8	3.3	4-1/2
2	4 1/2	4 3/4	6	1 1/16	3/4	4.4	4-5/8
3	5 1/2	6	7 1/2	1 1/4	3/4	8.3	4-5/8
4	6 1/2	7 1/2	9	1 3/8	3/4	13.0	8-5/8
6	8	9 1/2	11	1 9/16	7/8	20.8	8-3/4
8	9	11 3/4	13 1/2	2 1/16	7/8	36.4	8-3/4
10	11	14 1/4	16	3 1/16	1	52.6	12-7/8
12	12	17	19	3 1/16	1	73.4	12-7/8

Fig. 257F 90° Long Radius Elbow, Flanged

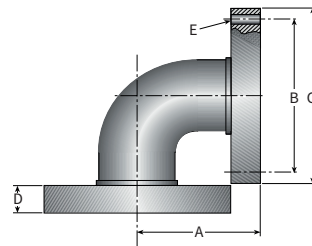

Size (in)	A ±1/16 (in.)	B Ref (in.)	C Ref (in.)	D Ref (in.)	E Ref (in.)	Wt. † (lb.)	Bolts No/Size
1	6 7/16	3 3/8	4 1/4	7/8	5/8	2.4	4-1/2
1 1/2	7 9/16	3 7/8	5	1 3/16	5/8	4.2	4-1/2
2	8 9/16	4 3/4	6	1 3/16	3/4	5.2	4-5/8
3	9 13/16	6	7 1/2	1 3/16	3/4	9.1	4-5/8
4	11 1/16	7 1/2	9	1 1/2	3/4	14.6	8-5/8
6	11 1/2	9 1/2	11	1 9/16	7/8	17.1	8-3/4
8	14	11 3/4	13 1/2	2 1/16	7/8	29.3	8-3/4
10	16 1/2	14 1/4	16	3 1/16	1	52.6	12-7/8
12	19	17	19	3 1/16	1	72.2	12-7/8
14	26 3/8**	18 3/4	21	4 3/8	1 1/8	134.6	12-1

Fig. 257S* 90° Long Radius Elbow, Flange x Socket

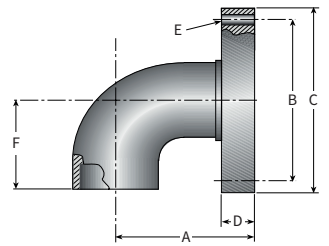

Size (in)	A ± 1/8 (in.)	B Ref (in.)	C Ref (in.)	D Ref (in.)	E Ref (in.)	F ± 1/8 (in.)	Wt. † (lb.)	Bolts No/Size
1	6 7/16	3 3/8	4 1/4	7/8	5/8	5	1.7	4-1/2
1 1/2	7 9/16	3 7/8	5	1 3/16	5/8	6	2.8	4-1/2
2	8 9/16	4 3/4	6	1 3/16	3/4	6 1/2	3.3	4-5/8
3	9 13/16	6	7 1/2	1 3/16	3/4	7 3/4	5.8	4-5/8
4	11 1/16	7 1/2	9	1 1/2	3/4	9	8.5	8-5/8
6	12 7/8	9 1/2	11	1 9/16	7/8	10 3/16	14.4	8-3/4
8	17 3/16	11 3/4	13 1/2	2 1/16	7/8	14 5/8	25.7	8-3/4
10	21 15/16	14 1/4	16	3 1/16	1	17 1/16	49.7	12-7/8
12	24 7/16	17	19	3 1/16	1	20 3/16	65.2	12-7/8
14*	26 3/8	18 3/4	21	4 3/8	1 1/8	22	105.1	12-1

* Available on order only - nonreturnable

** Tolerance exception - Fig. 257F x 14 - A ±1/8

† CL weight, multiply by 1.07 for RB, 1.1 for ZC

Elbows (Continued)

Fig. 265C 45° Short Radius Elbow, Socket

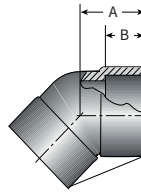

Size (in)	A		B Ref* (in.)	Wt. † (lb.)
	PM ± 1/16 (in.)	HLU ± 1/8 (in.)		
1	1	1 3/4*	1 3/16	0.7
1 1/2	1 1/2	2 1/4*	1 5/16	0.6
2	2	2 1/2*	1 3/8	1.3
3	3	3*	1 3/8	2.1
4	4	4*	1 3/8	3.4
6	6	5*	1 3/8	7.0
8	8	5 15/16	2 5/8	7.7
10	10	7 11/16	4	15.8
12	12	8 11/16	4	20.2
14	14	9 3/8	4	24.5

Fig. 265F 45° Short Radius Elbow, Flanged

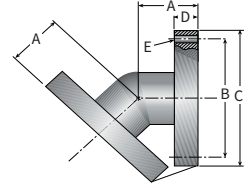

Size (in)	A		B Ref (in.)	C Ref (in.)	D Ref (in.)	E Ref (in.)	Wt. † (lb.)	Bolts No/Size
	PM ± 1/16 (in.)	HLU ± 1/8 (in.)						
1	3 15/16	3 3/16*	3 3/8	4 1/4	7/8	5/8	2.1	4-1/2
1 1/2	4 3/8	3 13/16*	3 7/8	5	1 3/16	5/8	3.3	4-1/2
2	2 1/2	4 9/16*	4 3/4	6	1 1/16	3/4	5.4	4-5/8
3	3	5 1/16*	6	7 1/2	1 1/4	3/4	6.6	4-5/8
4	4	6 1/16*	7 1/2	9	1 3/8	3/4	13.0	8-5/8
6	6 13/16	7 1/16*	9 1/2	11	1 1/16	7/8	20.3	8-3/4
8	-	5 1/2	11 3/4	13 1/2	2 1/16	7/8	23.8	8-3/4
10	-	6 1/2	14 1/4	16	3 1/16	1	56	12-7/8
12	-	7 1/2	17	19	3 1/16	1	77	12-7/8
14	-	13 3/4	18 3/4	21	4 3/8	1 1/8	115	12-1

Fig. 265S* 45° Elbow, Flange x Socket

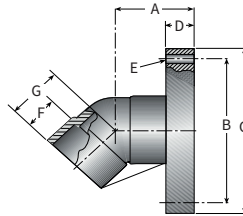

Size (in)	A		B Ref (in.)	C Ref (in.)	D Ref (in.)	E Ref (in.)	F Ref (in.)	G		Wt. † (lb.)	Bolts No/Size
	PM ± 1/16 (in.)	HLU ± 1/8 (in.)						PM ± 1/16 (in.)	HLU ± 1/8 (in.)		
1	3 15/16	3 3/16*	3 3/8	4 1/4	7/8	5/8	1 3/16	2 1/2	1 3/4	1.3	4-1/2
1 1/2	3 3/8	3 13/16*	3 7/8	5	1 3/16	5/8	1 5/16	2 5/16	2 1/4	2.0	4-1/2
2	5 5/16	4 9/16*	4 3/4	6	1 3/16	3/4	1 13/16	3 1/4	2 1/2	3.2	4-5/8
3	5 13/16	5 1/16*	6	7 1/2	1 3/16	3/4	1 13/16	3 3/4	3	4.9	4-5/8
4	6 1/8	6 1/16*	7 1/2	9	1 1/2	3/4	1 13/16	4 1/16	4	8.0	8-5/8
6	6 13/16	7 1/16*	9 1/2	11	1 1/16	7/8	1 13/16	4 3/4	5	13.7	8-3/4
8	-	8 1/2	11 3/4	13 1/2	2 1/16	7/8	2 5/8	-	5 15/16	15.9	8-3/4
10	-	11 15/16	14 1/4	16	3 1/16	1	4	-	7 11/16	39.3	12-7/8
12	-	12 15/16	17	19	3 1/16	1	4	-	8 11/16	57.5	12-7/8
14	-	13 3/4	18 3/4	21	4 3/8	1 1/8	4	-	9 3/8	70	12-1

* Available on order only - nonreturnable

† CL weight, multiply by 1.07 for RB, 1.1 for ZC

Tees

Size (in)	A		B		C ± 1/8 (in.)	Bolts No/Size
	PM ± 1/16 (in.)	HLU ± 1/8 (in.)	PM ± 1/16 (in.)	HLU ± 1/8 (in.)		
1	2 1/2	3 1/2*	5	7	1 3/16	0.8
1 1/2	2 3/4	4*	5 1/2	8	1 5/16	0.9
2	3 1/16	4 1/2*	7 5/8	9	1 13/16	2.1
3	4 7/16	5 1/2*	8 7/8	11	1 13/16	3.4
4	5 1/16	6 1/2*	10 1/8	13	1 13/16	5.3
6	-	8	-	16	1 13/16	11.2
8	-	7 1 1/16	-	15 3/8	2 5/8	15.5
10	-	12 3/16	-	24 3/8	4	29.3
12	-	13 3/16	-	26 3/8	4	38.8
14	-	13 5/8	-	27 1/4	4	40.8

Fig. 275C Tee, Socket

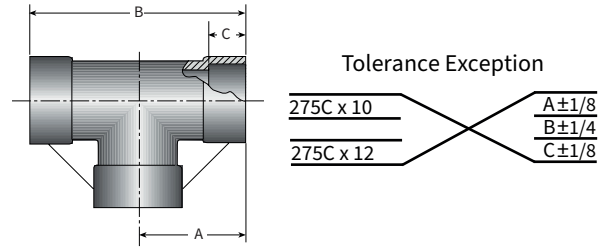

Size (in)	A		B		C Ref (in.)	D Ref (in.)	E Ref (in.)	F Ref (in.)	Wt. † (lb.)	Bolts No/Size
	PM ± 1/16 (in.)	HLU ± 1/8 (in.)	PM ± 1/16 (in.)	HLU ± 1/8 (in.)						
1	3 15/16	4 15/16	7 7/8	9 7/8	4 1/4	7/8	5/8	3 3/8	2.9	4-1/2
1 1/2	4 13/16	5 5/16	9 5/8	11 1/8	5	1 3/16	5/8	3 7/8	5.0	4-1/2
2	4 1/2	6 1/16	9	13 1/8	6	1 1/16	3/4	4 3/4	7.6	4-5/8
3	5 1/2	7 1/16	11	15 1/8	7 1/2	1 1/4	3/4	6	12.6	4-5/8
4	6 1/2	8 1/16	13	17 1/8	9	1 3/8	3/4	7 1/2	19.0	8-5/8
6	-	8	-	16	11	1 1/16	7/8	9 1/2	32.7	8-3/4
8	-	9	-	18	13 1/2	2 1/16	7/8	11 3/4	51.7	8-3/4
10	-	11	-	22	16	3 1/16	1	14 1/4	90	12-7/8
12	-	12	-	24	19	3 1/16	1	17	125	12-7/8
14	-	18	-	36	21	4 3/8	1 1/8	18 3/4	180	12-1

Fig. 275F Tee, Flanged

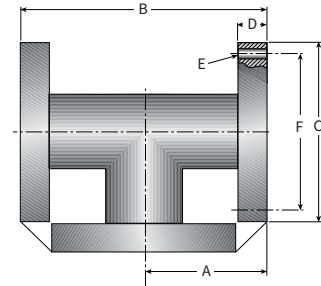

Size (in)	A		B Ref (in.)	C Ref (in.)	D Ref (in.)	E Ref (in.)	F Ref (in.)	G		Wt. †	
	PM ± 1/16 (in.)	HLU ± 1/8 (in.)						PM ± 1/16 (in.)	HLU ± 1/8 (in.)	One Flg (lb.)	Two Flgs (lb.)
1	3 15/16	4 15/16*	4 1/4	7/8	7/8	3 3/8	1 3/16	2 1/2	3 1/2	1.5	2.2
1 1/2	4 5/16	5 5/16*	5	1 3/16	5/8	3 7/8	1 5/16	2 3/4	4	2.2	3.5
2	5 7/8	6 1/16*	6	1 3/16	3/4	4 3/4	1 3/16	3 13/16	4 1/2	3.9	5.8
3	6 1/2	7 1/16*	7 1/2	1 3/16	3/4	6	1 3/16	4 7/16	5 1/2	7.0	10.6
4	7 1/8	8 1/16*	9	1 1/2	3/4	7 1/2	1 3/16	-	6 1/2	11.4	17.4
6 ♦	-	10 1/16	11	1 9/16	7/8	9 1/2	1 3/16	6	8	19.3	27.5
8	-	10 1/4	13 1/2	2 1/16	7/8	11 3/4	2 5/8	-	7 1 1/16	22.2	28.9
10	-	16 7/16	16	3 1/16	1	14 1/4	4	-	12 3/16	60	90
12	-	17 7/16	19	3 1/16	1	17	4	-	13 3/16	95	140

Fig. 275S* Tee, Flanged x Socket

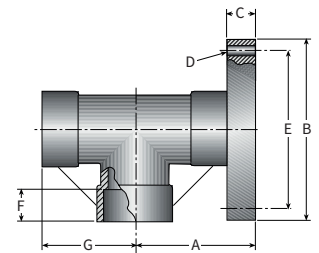

♦ 6 in. PM available in CL only
 * Available on order only - nonreturnable
 †CL weight, multiply by 1.07 for RB, 1.1 for ZC

Laterals

Fig. 266C Lateral Socket

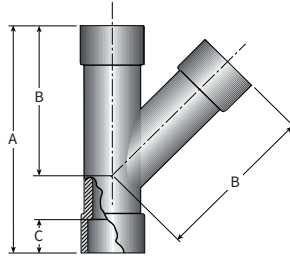

Size (in)	A ± ¼ (in.)	B ± ¼ (in.)	C ± ⅛ (in.)	Wt. † (lb.)
2	10 ⅞	7 ½	1 ⅜ ⅙	2.0
3	11 ⅞	8 ⅝ ⅙	1 ⅜ ⅙	3.7
4	13 ⅞ ⅙	11	1 ⅜ ⅙	8
6	24 ½	17 ⅞	1 ⅜ ⅙	13.9
8	29 ¼	21 ⅝ ⅙	2 ⅞	35.5
10	36 ⅞	26 ⅞ ⅙	4	51.7
12	43 ¼	31 ⅝ ⅙	4	69.1

Note: Reducing Laterals and crosses are available on request.

Fig. 266F* Lateral, Flanged

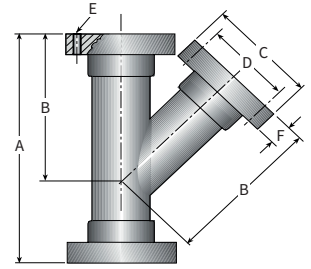

Size (in)	A ± ⅛ (in.)	B ± ⅛ (in.)	C Ref (in.)	D Ref (in.)	E Ref (in.)	F Ref (in.)	Wt. † (lb.)	Bolts No/Size
2	12 ½	8 ⅝ ⅙	6	4 ¾	¾	1 ⅞ ⅙	7.6	4-5/8
3	14 ½	10 ⅞	7 ½	6	¾	1 ¼	12.6	4-5/8
4	16 ⅞ ⅙	12 ½	9	7 ½	¾	1 ⅜	19.0	8-5/8
6	28 ⅞	19 ⅞ ⅙	11	9 ½	⅞	1 ⅞ ⅙	32.7	8-3/4
8	31 ¾	22 ⅞ ⅙	13 ½	11 ¾	⅞	2 ⅞ ⅙	51.7	8-3/4
10	45 ⅞	30 ⅞ ⅙	16	14 ¼	1	3 ⅞ ⅙	112	12-7/8
12	51 ¾	36 ⅞ ⅙	19	17	1	3 ⅞ ⅙	152	12-7/8

Crosses

Fig. 285C Cross, Socket

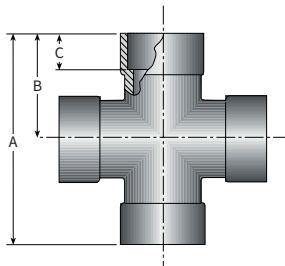

Size (in)	A ± ¼ (in.)	B ± ⅛ (in.)	C ± ⅛ (in.)	Wt. † (lb.)
2	6 ⅞	3 ⅞ ⅙	11 ⅜ ⅙	1.4
3	8	4	11 ⅜ ⅙	2.3
4	10 ⅞	5 ⅞ ⅙	11 ⅜ ⅙	5.5
6	16	8	11 ⅜ ⅙	15.7
8	15 ⅞	7 ⅞ ⅙	2 ⅞	15.5
10	24 ⅞	12 ⅞ ⅙	4	45.6
12	26 ⅞	13 ⅞ ⅙	4	57.2

Fig. 285F* Cross, Flanged

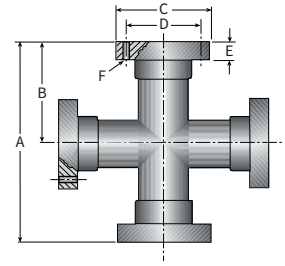

Size (in)	A ± ⅛ (in.)	B ± ⅛ (in.)	C Ref (in.)	D Ref (in.)	C Ref (in.)	C Ref (in.)	Wt. † (lb.)	Bolts No/Size
2	8 ¾	4 ⅞	6	4 ¾	1 ⅞ ⅙	¾	9.3	4-5/8
3	10 ⅞	5 ⅞ ⅙	7 ½	6	1 ⅞ ⅙	¾	13.9	4-5/8
4	13 ⅞	6 ⅞ ⅙	9	7 ½	1 ½	¾	23.5	8-5/8
6	16	8	11	9 ½	1 ⅞ ⅙	⅞	57.5	8-3/4
8	18	9	13 ½	11 ¾	2 ⅞ ⅙	⅞	71.7	8-3/4
10	22	11	16	14 ¼	3 ⅞ ⅙	1	126	12-7/8
12	24	12	19	17	3 ⅞ ⅙	1	170	12-7/8

* Available on order only - nonreturnable.

† CL weight, multiply by 1.07 for RB, 1.1 for ZC

Pipe Support/Wear Pad

Size (in)	R	L ± 1/8 (in.)	T Ref (in.)
1	1 1/16	3	1 3/32
1 1/2	1 3/8	3	7/16
2	1 7/32	4	1 1/32
3	2 3/32	4	1 1/32
4	2 5/8	4	3/8
6	3 15/16	4	5/8
8	4 9/16	5 5/8	5/8
10	6 1/8	8 3/8	3/4
12	7 3/32	8 3/8	2 3/32
14*	7 29/32	8 3/8	2 5/32

Fig. 391 Pipe Support

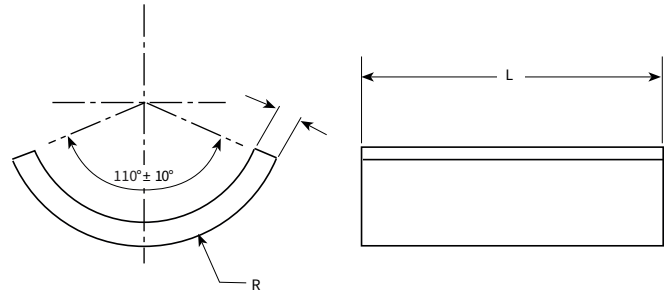

*Available on order only - nonreturnable.

Floor Drain



Fig. 203 Sealable Floor Drain

Sealable Drain Dimensional Data

Size (in)	A ± 1/8 (in.)	B (in.)	C (in.)	D (in.)	E (in.)	F ± 1/8 (in.)	G (in.)	H (in.)	I (in.)
6x2	6 1/4	2 3/8	2	6 3/8	6	8 7/8	5 3/4	7	7 3/4
6x3	6 1/4	3 1/2	2	6 3/8	6	8 7/8	5 3/4	7	7 3/4
6x4	6	4 1/2	2	6 3/8	6	8 7/8	5 3/4	7	7 3/4
12x4	8 1/16	4 1/2	1 9/16	13 3/8	8	15 1/2	12 3/4	14	14 1/2
12x6	8 1/16	6 5/8	1 9/16	13 3/8	8	15 1/2	12 3/4	14	14 1/2
12x8	8	8 5/8	1 9/16	13 3/8	8	15 1/2	12 3/4	14	14 1/2

Note: Standard outlet straight socket. 2- 6 in. FNPT outlet available on request.

Sealable Drain Standard Configurations

Description	Figure	Viton Plug	1/4 in. Solid Cover Plate with O-Ring Seal	1/4 in. Drilled Drain Grate	16 Gauge Strainer Basket
Clean Out	203CO	✓	✓		
Floor Drain	203FD	✓		✓	✓
Equipment Drain	203ED	✓	✓		✓

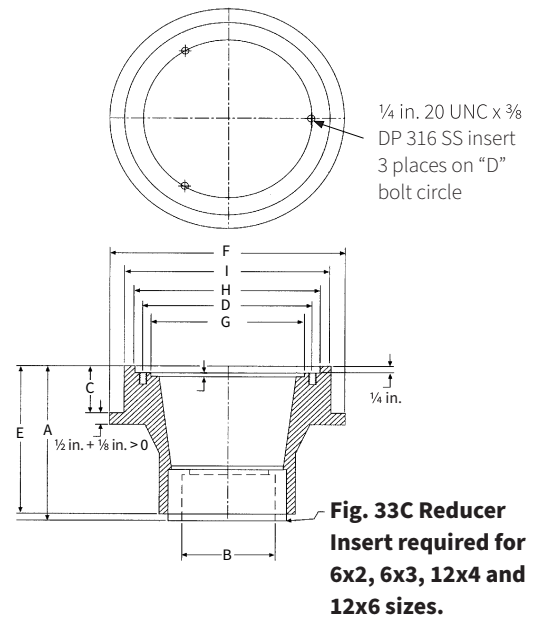
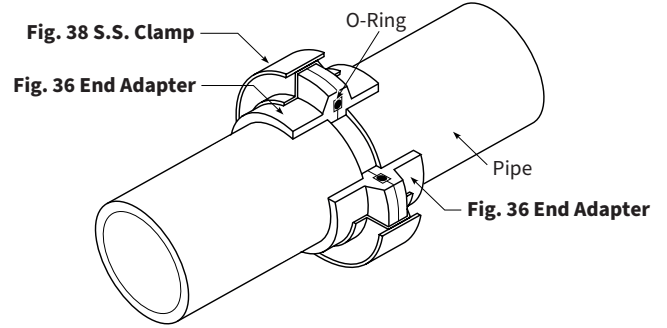

Fig. 33C Reducer Insert required for 6x2, 6x3, 12x4 and 12x6 sizes.

Centriclump

Physical Data

Size (in.)	Pressure Rating		Max Rec. Torque (in-lbs.)	Precision O-Ring Size	Wrench Size (in.)
	EP @225°	VE @175°			
2	150	150	50	333	7/16
3	150	150	75	342	7/16
4	150	150	150	428	1/2
6	150	150	150	441	1/2
8	150	125	175	448	1/2



Size (in.)	A Ref (in.)	B Ref (in.)	C Ref (in.)	Wt. † (lb.)
2	3 3/4	2 1/16	1 3/16	0.5
3	5	2 1/16	1 3/16	0.7
4	6 3/8	2 1/16	1 3/16	1.2
6	8 7/8	2 1/16	1 3/16	2.2
8	11 1/2	2 1/16	1 3/16	3.8

Fig. 36* End Adapter

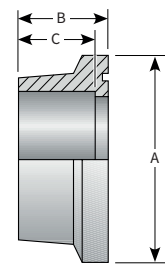

Size (in.)	A Ref (In.)	B Ref (In.)	C Ref (In.)	Nut(s)		Wt. † (lb.)
				No.	Size (in.)	
2	1 5/16	4	3	1	7/16	0.5
3	1 3/8	5 1/4	3 3/8	1	7/16	0.7
4	1 3/4	7	5	1	1/2	1.2
6	2 1/16	9 1/4	5 5/8	1	1/2	2.4
8	2 9/16	12	7 1/2	1	1/2	5.5

Fig. 38* SS Clamp

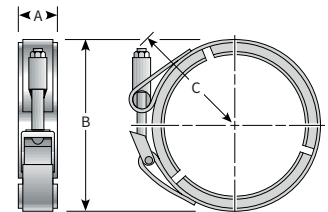

Size (in.)	A Ref (in.)	B Ref (in.)	C Ref (in.)
2	3 3/4	1 1/16	3 1/8
3	5	1 1/8	4 5/16
4	6 3/8	1 1/4	5 5/16
6	8 7/8	1 1/2	7 15/16
8	11 1/2	2	10 5/16

Fig. 39* Blind Flange

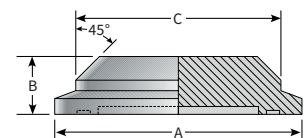

* Available on order only - nonreturnable.

† CL weight, multiply by 1.07 for RB, 1.1 for ZC

Assembled Fittings Reference Dimensions (Continued)

Size (in.)	A Ref (in.)	B Ref (in.)	C Ref (in.)
1½	2¾	2 ¹⁵ / ₁₆	1 ⁵ / ₁₆
2	3 ¹ / ₁₆	3½	1 ⁵ / ₁₆
3	4 ⁷ / ₁₆	4 ⁵ / ₈	1 ¹³ / ₁₆
4	5 ¹ / ₁₆	5¼	1 ¹³ / ₁₆
6	6	6 ³ / ₁₆	1 ¹³ / ₁₆
8	7½	7½	2 ⁵ / ₁₆

Fig. 255CR* 90° Short Radius Reducer, Socket

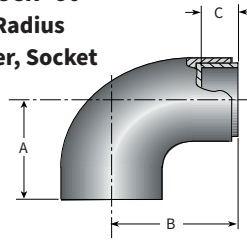

Assemble using Fig. 255C Elbow and Fig. 33 Reducer Bushing

Size (in.)	A Ref (in.)	B Ref (in.)	C Ref (in.)
6	10 ¹³ / ₁₆	11	1 ¹³ / ₁₆
8	14 ⁵ / ₈	14 ⁵ / ₈	2 ⁵ / ₁₆
10	17 ¹¹ / ₁₆	17 ⁷ / ₈	4
12	20 ³ / ₁₆	20 ³ / ₁₆	4

Fig. 257CR* 90° Long Radius Reducer, Socket

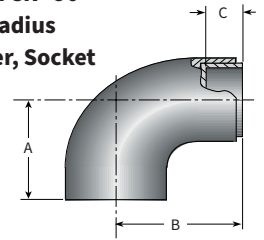

Assemble using Fig. 257C Elbow and Fig. 33 Reducer Bushing

Fig. 255FR* 90° Short Radius Reducer, Flanged

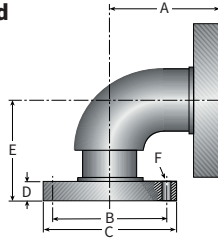

Size (in.)	A Ref (in.)	B Ref (in.)	C Ref (in.)	D Ref (in.)	E Ref (in.)	F Ref (in.)	Bolts No/Size
1½ x 1	4 ⁵ / ₁₆	3 ³ / ₈	4¼	7 ¹ / ₈	6 ³ / ₁₆	¾	4-½
2 x 1½	5 ⁷ / ₈	3 ⁷ / ₈	5	1 ³ / ₁₆	7	¾	4-5/8
3 x 2	6½	4¾	6	1 ³ / ₁₆	7 ⁵ / ₈	¾	4-5/8
4 x 3	7 ¹ / ₈	6	7½	1 ³ / ₁₆	8¼	¾	4-5/8
6 x 4	8 ¹ / ₁₆	7½	9	½	9½	¾	8-5/8
8 x 6	10 ¹ / ₁₆	9½	11	1 ⁹ / ₁₆	10½	7 ⁸ / ₁₆	8-¾

Assemble using Fig. 255C Elbow and Fig. 33 Reducer Bushing, Fig. 17 Pipe Stub and Fig. 18 Socket Flange

Fig. 257FR* 90° Long Radius Reducer, Flanged

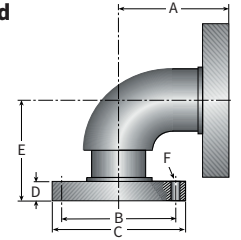

Size (in.)	A Ref (in.)	B Ref (in.)	C Ref (in.)	D Ref (in.)	E Ref (in.)	F Ref (in.)	Bolts No/Size
6 x 4	12 ⁷ / ₈	7½	9	1½	14 ⁵ / ₁₆	¾	8-5/8
8 x 6	17 ³ / ₁₆	9½	11	1 ⁹ / ₁₆	17 ³ / ₈	7 ⁸ / ₁₆	8-¾
10 x 8	21 ⁵ / ₁₆	11¾	13½	2 ¹ / ₁₆	21¼	7 ⁸ / ₁₆	8-¾
12 x 10	24 ⁷ / ₁₆	14¼	16	3 ¹ / ₁₆	26 ³ / ₈	1	12-7/8

Assemble using Fig. 257C Elbow, Fig. 33 Reducer Bushing, Fig. 17 Pipe Stub and Fig. 18 Socket Flange

Fig. 265CR⁽³⁾ 45° Reducer, Socket

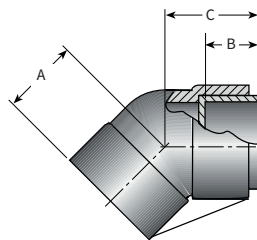

Size (in.)	A		B		C Ref (in.)
	PM± ¹ / ₁₆ (in.)	HLU± ¹ / ₈ (in.)	PM Ref (in.)	HLU Ref (in.)	
1½	2 ⁵ / ₁₆	2¼	2½	2 ⁷ / ₁₆	1 ⁵ / ₁₆
2	3¼	2½	2 ¹⁵ / ₁₆	2 ³ / ₁₆	1 ⁵ / ₁₆
3	3¾	3	3 ¹⁵ / ₁₆	3 ³ / ₁₆	1 ¹³ / ₁₆
4	4 ¹ / ₁₆	4	4¼	4 ³ / ₁₆	1 ¹³ / ₁₆
6	4¾	5	4 ¹⁵ / ₁₆	5 ³ / ₁₆	1 ¹³ / ₁₆
8	-	5 ¹⁵ / ₁₆	-	5 ³ / ₁₆	2 ⁵ / ₁₆
10	-	7 ¹ / ₁₆	-	7 ⁷ / ₈	4
12	-	8 ¹ / ₁₆	-	8 ⁷ / ₈	4

Assemble using Fig. 265C Elbow and Fig. 33 Reducer Bushing

Fig. 265FR^{(3)*} 45° Reducer, Flanged

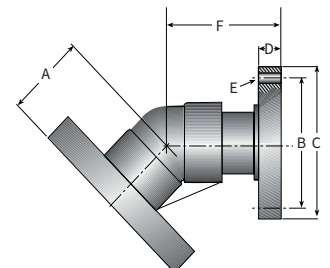

Size (in.)	A		B Ref (in.)	C Ref (in.)	D Ref (in.)	E Ref (in.)	F Ref (in.)	Bolts No/Size
	PM± ¹ / ₁₆ (in.)	HLU± ¹ / ₈ (in.)						
1½ x 1	3 ³ / ₈	3 ³ / ₁₆	3 ³ / ₈	4¼	7 ¹ / ₈	5 ⁸ / ₁₆	5¾	4-½
2 x 1½	5 ⁵ / ₁₆	4 ⁹ / ₁₆	3 ⁷ / ₈	5	1 ³ / ₁₆	5 ⁸ / ₁₆	7 ⁵ / ₁₆	4-5/8
3 x 2	5 ¹³ / ₁₆	5 ¹ / ₁₆	4¾	6	1 ³ / ₁₆	¾	7 ¹³ / ₁₆	4-5/8
4 x 3	6 ¹ / ₈	6 ¹ / ₁₆	6	7½	1 ³ / ₁₆	¾	8 ¹ / ₈	8-5/8
6 x 4 ♦	6 ¹³ / ₁₆	7 ¹ / ₁₆	7½	9	1½	7 ⁸ / ₁₆	8¼	8-¾
8 x 6	-	8½	9½	11	1 ⁹ / ₁₆	7 ⁸ / ₁₆	8 ¹ / ₁₆	8-¾
10 x 8	-	11 ⁵ / ₁₆	11¾	13½	2 ¹ / ₁₆	1	11¼	12-7/8
12 x 10	-	12 ¹⁵ / ₁₆	14¼	16	3 ¹ / ₁₆	1	14 ⁷ / ₈	12-7/8

Assemble using Fig. 265F Elbow and Fig. 33 Reducer Bushing, Pipe Stubs and Fig. 18 Socket Flanges

♦ 6 in. PM available in CL only * Available on order only - nonreturnable.

(3) Reductions beyond one pipe size for reduced pressure applications are available. (See Fig. 33)

Assembled Fittings Reference Dimensions (Continued)

Fig. 275CR* Reducer, Socket

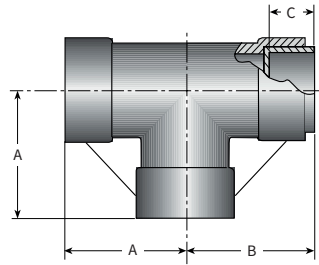

Size (in.)	A		B		C Ref (in.)
	PM ± 1/16 (in.)	HLU ± 1/8 (in.)	PM Ref (in.)	HLU Ref (in.)	
1 1/2	2 3/4	4	2 15/16	4	1 5/16
2	3 13/16	4 1/2	3 1/2	4 3/16	1 5/16
3	4 7/16	5 1/2	4 5/8	5 1/16	1 13/16
4	5 1/16	6 1/2	5 1/4	6 1/16	1 13/16
6 ♦	6	8	6 3/16	8 3/16	1 13/16
8	-	7 1/16	-	7 9/16	2 5/16
10	-	12 3/16	-	12 3/8	4
12	-	13 3/16	-	13 3/8	4

Assemble using Fig 275C and Fig 33 Reducer Bushing

Size (in.)	A (in.)
1	2 3/8
1 1/2	2 5/8
2	3 3/8
3	3 5/8
4	3 5/8
6	3 5/8
8	5 1/4
10	8
12	8
14	8

Fig. 17 Assembly Pipe Stubs

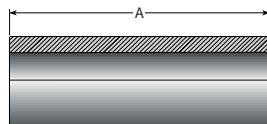
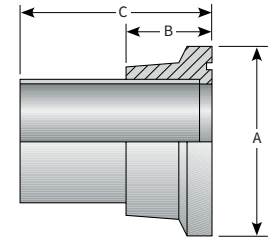
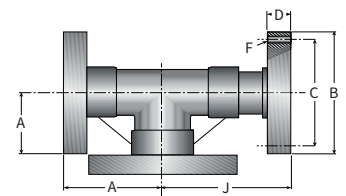

Fig. 37* Adapter Nipple



Size (in.)	A Ref (in.)	B Ref (in.)	C Ref (in.)	Wt. † (lb.)
2	3 3/4	2 1/16	4 13/16	1.0
3	5	2 1/16	4 13/16	1.7
4	6 3/8	2 1/16	4 13/16	2.2
6	8 7/8	2 1/16	4 13/16	4.0
8	11 1/2	2 1/16	4 13/16	6.3

Fig. 275FR(3)*Reducer, Flanged Single Size Reduction Shown



Size (in.)	A		B Ref (in.)	C Ref (in.)	D Ref (in.)	F Ref (in.)	J Ref (in.)
	PM Ref	HLU Ref					
1 1/2 x 1	4 5/16	5 9/16	4 1/4	3 1/8	7/8	5/8	6 3/16
2 x 1 1/2	5 7/8	6 9/16	5	3 7/8	1 3/16	5/8	7
3 x 2	6 1/2	7 9/16	6	4 3/4	1 3/16	3/4	7 5/8
4 x 3	7 1/8	8 9/16	7 1/2	6	1 3/16	3/4	8 1/4
6 x 4	8 1/16	10 1/16	9	7 1/2	1 1/2	3/4	9 1/2
8 x 6	-	10 1/4	11	9 1/2	1 9/16	7/8	10 9/16
10 x 8	-	16 7/16	13 1/2	11 3/4	2 1/16	7/8	15 11/16
12 x 10	-	17 1/16	16	14 1/4	3 1/16	1	19 3/8

♦ 6 in. PM available in CL only

* Available on order only - nonreturnable.

(3) Reductions beyond one pipe size for reduced pressure applications are available. (See Fig. 33)

Dimensions

Take off Dimensions for Adhesive Socket Fittings

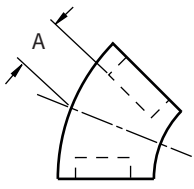

45° ELBOW
Fig. 265C

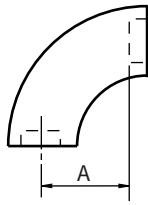

90° SHORT or LONG RADIUS ELBOW
Fig. 255C

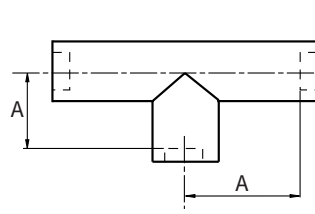

TEE
Fig. 275C

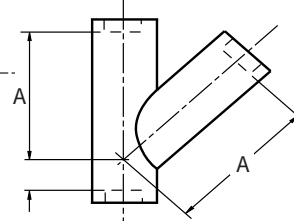

LATERAL
Fig. 266C

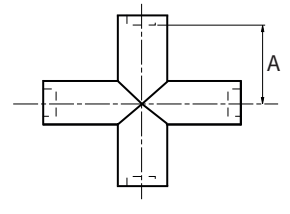

CROSS
Fig. 285C

Pipe Stop to Fittings' Center Line Dimensions

Size (in.)	45° Elbow		Short Radius 90° Elbow	Long Radius 90° Elbow	Tee		Lateral	Cross	
	PM A (in.)	HLU A (in.)	A (in.)	A (in.)	PM A (in.)	HLU A (in.)	A (in.)	B (in.)	A (in.)
1	15/16	9/16	15/16	33/16	15/16	25/16	-	-	-
1 1/2	1	15/16	17/16	41/16	17/16	21/16	-	-	-
2	17/16	1 1/16	2	41/16	2	2 1/16	5 1/16	1 3/16	1 3/8
3	1 15/16	1 3/16	2 5/8	5 19/16	2 5/8	3 1/16	7 1/8	1 1/8	2 3/16
4	2 1/4	2 3/16	3 1/4	7 3/16	3 1/4	4 1/16	9 3/16	7/8	3 1/2
6	2 15/16	3 3/16	4 3/16	9	-	6 3/16	15 5/16	5 5/16	6 3/16
8	-	3 5/16	4 7/8	12	-	5 1/16	18 1/16	5 5/16	5 1/16
10	-	3 1/16	-	13 1/16	-	8 3/16	22 7/16	6 7/16	8 3/16
12	-	4 1/16	-	16 3/16	-	9 3/16	27 1/16	7 9/16	9 3/16
14	-	5 3/8	-	18	-	9 5/8	-	-	-

How to Read Flanged or Reducing Fittings

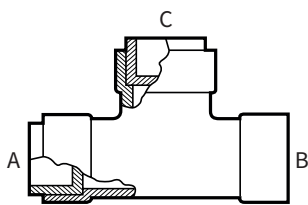

TEE

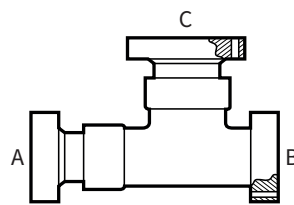

CROSS

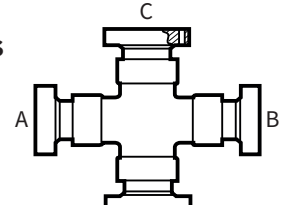

Run x Run x Branch
(A x B x C)

Run x Run x Branch x Branch
(A x B x C x D)

The sequences illustrated should be used when describing fitting outlets. Drawings or sketches showing outlet types, locations, sizes and dimensional requirements are required for more complicated fitting configurations.

Special Configuration Fittings

Contact NOV Fiber Glass Systems for Details

- 1/16 through 12 in. Orifice flanges, 150# & 300#
- Odd degree elbows, 15, 22 1/2, 30 & 60 degree
- 5D Socket & Flanged Elbows
- Sump Fittings
- 4 in. thru 10 in. Reducing Lateral, Socket, Fig. 266CR
- 2 in. thru 12 in. Fig 267F Long Turn Tee, Socket, Fig. 267C

- 2 in. thru 12 in. Long Turn Tee, Flanged, Fig 267F
- 2 in. thru 12 in. 45° Double Y Branch, Socket, Fig. 268C
- 2 in. thru 12 in. 45° Double Y Branch, Flanged, Fig. 268F
- 2 in. thru 12 in. 90° Double Y Branch, Socket, Fig. 269C
- 2 in. thru 12 in. 90° Double Y Branch, Flanged, Fig. 269F

Adhesives

Weldfast ZC-275 Epoxy Adhesive for Adhesive Socket Joints

Order for Z-Core epoxy piping systems. Weldfast ZC-275 adhesive can also be used to bond RB and CL pipe and fittings. Usage should be limited to applications recommended for both Z-Core product and the pipe and fittings grade being used.

Contents:

- Adhesive (Part A)
- Hardener (Part B)
- Wooden Stir Stick Plastic Putty Knife
- Fabrication Instructions

No. 1 Kit Size -½ Pint	
Number of Bonds Per Kit	
Joints	Pipe Size
12	1 in. connections
10	1½ in. connections
8	2 in. connections
5	3 in. connections
3	4 in. connections
2	6 in. connections
1	8 in. connections
½	10 in. connections
½	12 in. connections

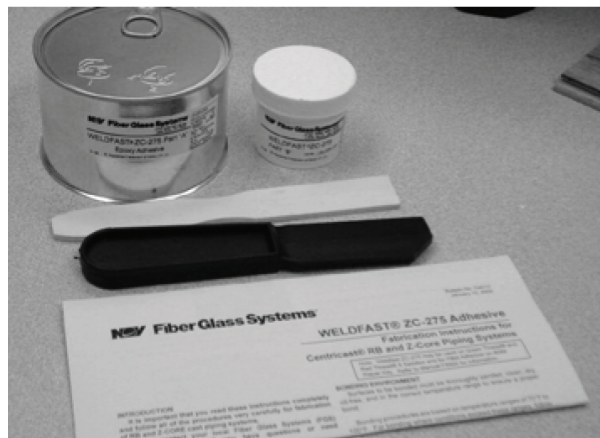

For complete instructions, refer to fab Bulletin D4090 included in each kit of WELDFAST ZC-275 Adhesive.

Weldfast CL-200-QS Part “C”



Accelerator used with WELDFAST CL-200 to provide a quick set vinyl ester adhesive. Joints fabricated with this quick set adhesive can be made and quickly cured in as little as one hour (at room temperature) compared to 24 hours (at room temperature) for conventional adhesives.

Weldfast CL-200

Contents:

- Adhesive (Part A)
- Catalyst
- Wooden Stir Stick
- Plastic Putty Knife
- Fabrication Instructions

Order for CL-2030 and CL-1520 vinyl ester piping systems.

No. 1 Kit Size-½ Pint	
Number of Bonds Per Kit	
Joints	Pipe Size
12	1 in. connections
10	1½ in. connections
8	2 in. connections
5	3 in. connections
3	4 in. connections
2	6 in. connections
1	8 in. connections
½	10 in. connections
½	12 in. connections
⅓	14 in. connections



For complete instructions refer to fab Bulletin D4210 included in each kit of WELDFAST CL-200.

Accessories

Strap Clamp Kit*

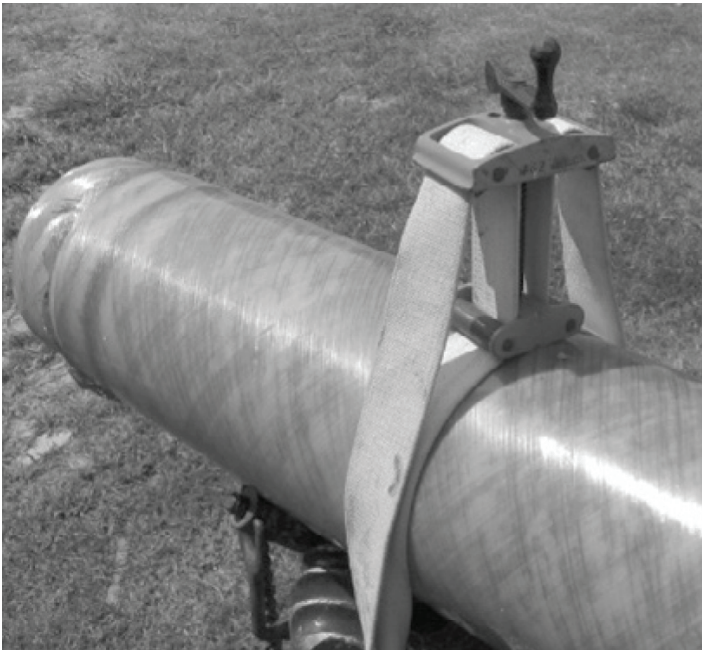

Silicone Rubber Heat Blanket*

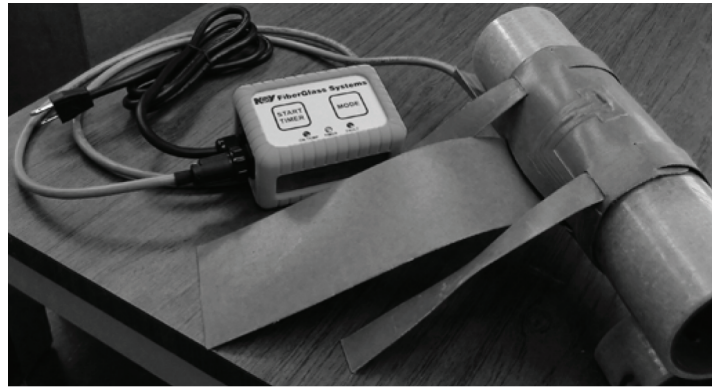

For Heat Curing 1-20 in. connections

Pipe Size	Model Number for Pipe Size
1 - 3 inches	B
4 - 8 inches	C
10 - 14 inches	D
16 - 20 inches	E

* Available on order only - nonreturnable.

Fiber Glass Systems

17115 San Pedro Avenue, Ste. 200, San Antonio, Texas 78232, USA
Phone: 210 477 7500 Fax: 210 477 7560

NOV Inc. has produced this brochure for general information only, and it is not intended for design purposes. Although every effort has been made to maintain the accuracy and reliability of its contents, NOV Inc. in no way assumes responsibility for liability for any loss, damage or injury resulting from the use of information and data herein nor is any warranty expressed or implied. Always cross-reference the bulletin date with the most current version listed at the web site noted in this literature.