

Titan Centrifuge

Large bowl, high volume centrifuge that reduces footprint, improves cut point, and increases safety and flexibility



The Titan™ large bowl, high volume centrifuge from Brandt™ makes operations faster and safer, all while maintaining a small rig footprint. Rig crews can now get quick and easy access to the Titan centrifuge from either side of the skid, and features a spring-assisted lid.

This technology also introduces an improved T-Conveyor design. Rather than smaller nozzles that create a detrimental jetting effect into the wall cake, the new self-cleaning conveyor uses fewer, larger nozzles for higher-flow rate applications that result in less internal wear and tear, while diminishing vibration. The innovative technology operates at full variable speed to process maximum flow rates at the finest cut point on the market. The new Titan solution has a narrow skid profile for a smaller footprint than ever before, while also being scalable to handle any size operation. It can also be paired with a smart controller that provides monitoring capabilities, remote access, and maintenance archive viewable on the Max™ Portal.

Contact your local NOV representative to learn how the Titan centrifuge can make your operations faster and safer, all while maintaining a small rig footprint.

Features and Benefits

Compact, light size

- A 52 in. wide footprint allows for the use of two centrifuges per stand
- Weighs less than the HS-2172 centrifuge, benefiting shipping and offshore operations
- Narrow skid profile, scalable to handle any size operation

Improved T-Conveyor design

- Self-cleaning conveyor uses fewer, larger nozzles for higher-flow rate applications that result in less internal wear and tear, while diminishing vibration
- Proprietary nozzle design reduces conveyor fluid velocity, cutting down on wall cake and mud disturbance

Finest cut point on the market

- Operates in full variable-speed mode to process maximum flow rates at the finest cut point
- Specifically engineered to produce an improved, precise cut point

Spring-adjustable lid

- Reversible and accessible from either side of the skid
- Easily opened by one person

Smart controller

- Option to pair with a controller that offers monitoring capabilities, remote access, and manual operations

Safety focus

- Gearbox containment to mitigate any axial movement
- Excess axial vibration shutdown protection
- Rotating Assembly over torque shutdown protection

Titan Centrifuge

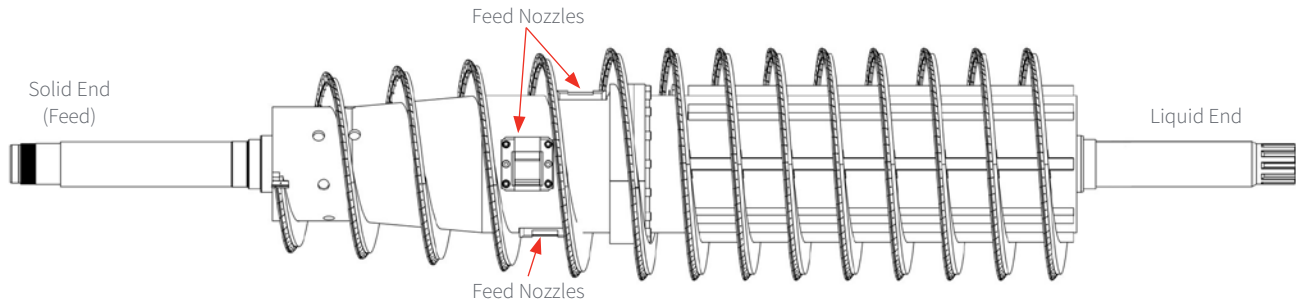

T Style Conveyor Sub Assembly

General	Titan Centrifuge
Length	196 in. (4978.4 mm)
Width	59½ in. (1501.77 mm)
Height	51¾ in. (1304.92 mm)
Weight	14030 lb (6363.90 kg)
Bowl Diameter	21 in. (533 mm)
Bowl Length	72 in. (1829 mm)
Maximum Bowl Speed	3000 RPM
Typical Bowl Speed	2400 RPM
Maximum Processing Capacity	550 gal/min (2082 L/min)
Drive Type	Variable Frequency Drive (VFD)
Maximum G-force	2684

Rotating assembly	Titan T Style Conveyor	Titan L Style Conveyor
Conveyor Pitch	6.25 in. (158.75 mm) (Beach Section) 4 in. (101.6 mm) (Cylindrical Section)	6.25 in. (158.75mm)
Conveyor Type	Single	Single
Feed Chamber Discharge Type	4 Nozzles	12 Nozzles
Gearbox Type	Planetary	Planetary
Gearbox Ratio	75:1	75:1

Power Requirements	Titan T Style Conveyor
Main Drive Motor	150 hp (112 kW)
Back Drive Motor	40 hp (30 kW)
Voltage*	460 VAC

* Optional 380, 480, and 575 VAC also available