



ST-80C² Iron Roughneck

The Next Generation

We are excited to offer the latest version of our ST-80C Iron Roughneck, the ST-80C². The new ST-80C² Iron Roughneck incorporates a multitude of improvements based on customer feedback and engineering analysis while still retaining the durability, ruggedness and performance of its predecessor. The improvements offer better control responsiveness, ease in serviceability and most importantly, operational features that promote rig floor personnel safety.

FEATURES

New control panel

- Hydraulic pilot controls and strategic lever placement for finer, more effective control
- Design offers hand protection
- Primary E-stop

Additional integrated control panel features

- System pressure gauge
- Hydraulic enable dial
- Torque adjust dial
- Arm adjust control - arm can be preset for desired reach while still being capable of full retraction to free up rig floor space

Upgraded gearbox casting

- Increased housing strength for impact resistance
- Oil-submerged with oil sight glass, easy access drain and oil level dipstick
- Splined motor shaft to increase shaft and gear life
- Reduction in parts and weight

Hydraulic secondary E-stop pull cord on lower arm

- Total system pressure cancellation to deactivate tool
- Pull cords accessible by rig floor personnel within tool's proximity

Improved control valve assembly

- Location outside of carriage frame for improved accessibility

Manifold relocation/optimization

- Location outside of carriage frame for improved accessibility
- Protective, easily removable steel guards
- Improved hose routing

Improved alignment plate

- Round tubing bar replaced with solid cross brace and curved guide on plate
- Plate integrated into frame for better stability and support

Improved quick disconnect service loop couplings

- Screw-to-connect quick disconnect couplings ensure positive connection and prevent unintended disconnection

Soft clamp

- Minimal clamp force applied to box connection during spinning operations
- Design aimed to reduce "bellling" of connections and extend tool joint life

Remote lift switch

- Safer method to relocate tool away from personnel by raising/lowering unit when full retracted, providing 77.7" clearance underneath

Improved hose routing

- Hydraulic system designed and located to ease hose routing and maintenance
- Hoses labeled with port identification

Improved slew jack screws

- Improved material, strength and support

Carriage assembly rubber guards

- Guards can be flipped up for maintenance or completely removed by removing a single pin

BENEFITS

- Enhanced safety features
- Improved accessibility to many facets of tool to aid in maintenance, removal and troubleshooting
- Increased efficiency in repetitive make/break and general tool tasks help streamline operations
- Finer control with improved sensitivity, reactivity and faster response times
- Features promote extended life of tool and tubulars
- Greater structural stability, strength, impact resistance and durability
- Improved user-interface, user-friendly
- Tool allows for retrofits into an existing ST-80C floor socket
- Some ST-80C² features may be applied to existing ST-80C tools

ST-80C² Iron Roughneck

ST-80C² Iron Roughneck Dimensions

Stored and extended dimensions

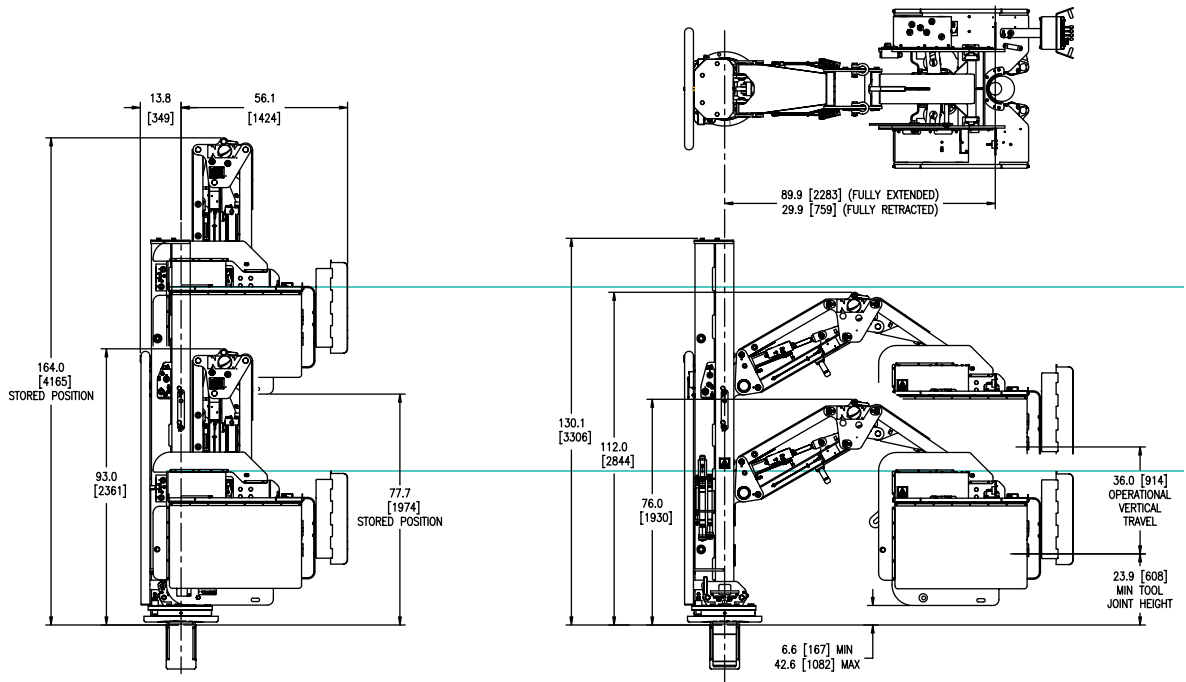

Technical Specifications

ST-80C² Iron Roughneck

Assembly Weight	7,800 lbs (3,538 kg)
Hydraulic Requirements	28 GPM @ 2,100 psi (106 LPM @ 145 bar) min 40 GPM @ 3,000 psi (151 LPM @ 207 bar) max
Tubular Connection (Tool Joint) Outer Diameter Range	4 ¼" to 8 ½"
Spin Speed	75 RPM (nominal on 5" drill pipe)
Spin Torque	1,750 ft-lb (2,373 N-m)
Maximum Makeup Torque	60,000 ft-lb (81,500 N-m)
Maximum Breakout Torque	80,000 ft-lb (108,500 N-m)
Connection Height	23" to 59" (584 mm to 1,489 mm)
Horizontal Travel	60" (1,524 mm)
Slew	±90°
Torque Wrench Rotation	30°

Control Panel

Offers finer, more effective control and better hand protection

Soft Clamp

Aims to reduce "belling" of connections and extend tool joint life

Secondary Emergency Stop Pull Cord

Deactivates tool with total system pressure cancellation

