

DRILLING FLUID PROCESSING SYSTEM

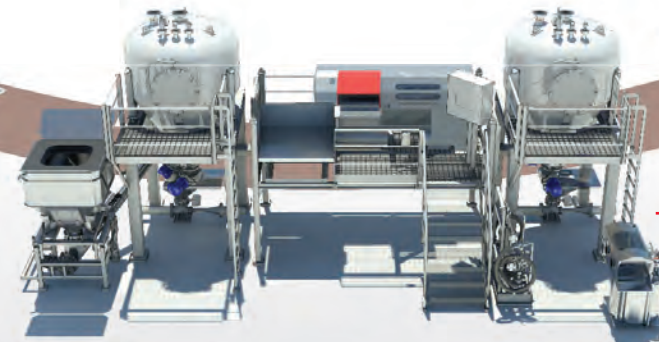

DRILLING FLUID PROCESSING SYSTEM

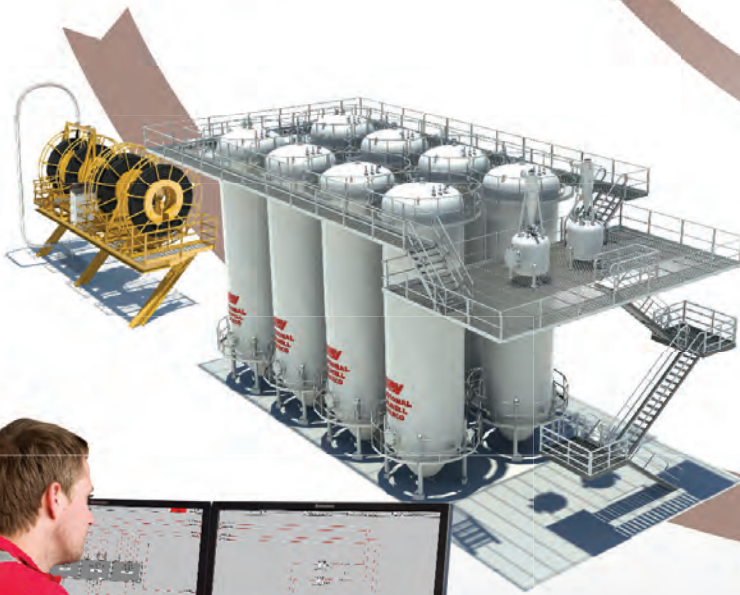
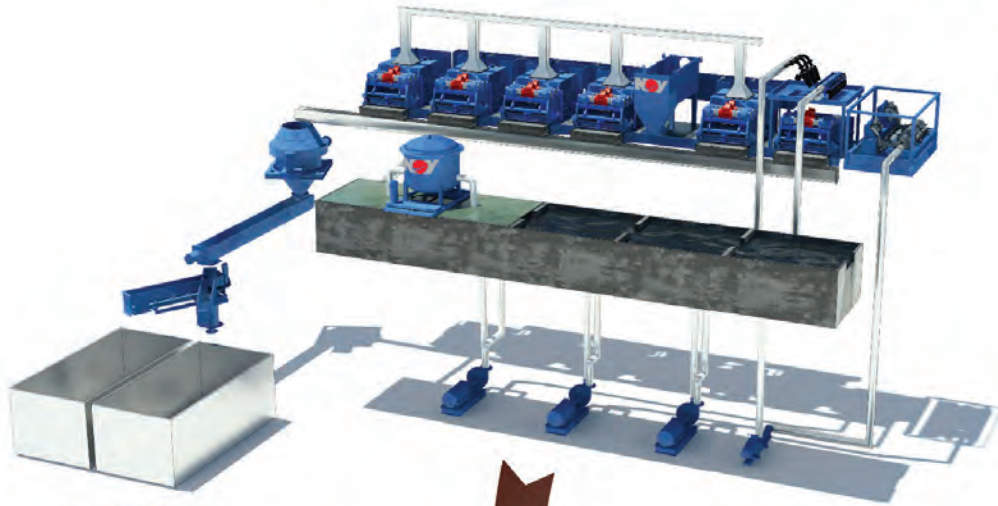

- “SEAL PERMEABLE FORMATIONS”
- “MAINTAIN WELLBORE STABILITY”
- “MINIMIZE FORMATION DAMAGE”
- “COOL, LUBRICATE AND SUPPORT THE BIT AND DRILLING ASSEMBLY”
- “SUSPEND AND TRANSPORT CUTTINGS FROM WELL”



Drilling Fluid Control System

Solids Control System

High Pressure Manifold System

Waste Management System

Drilling Fluid Storage and Pumping System

Drilling Fluid Mix / Additive System

Bulk Storage and Transfer System

Aftermarket

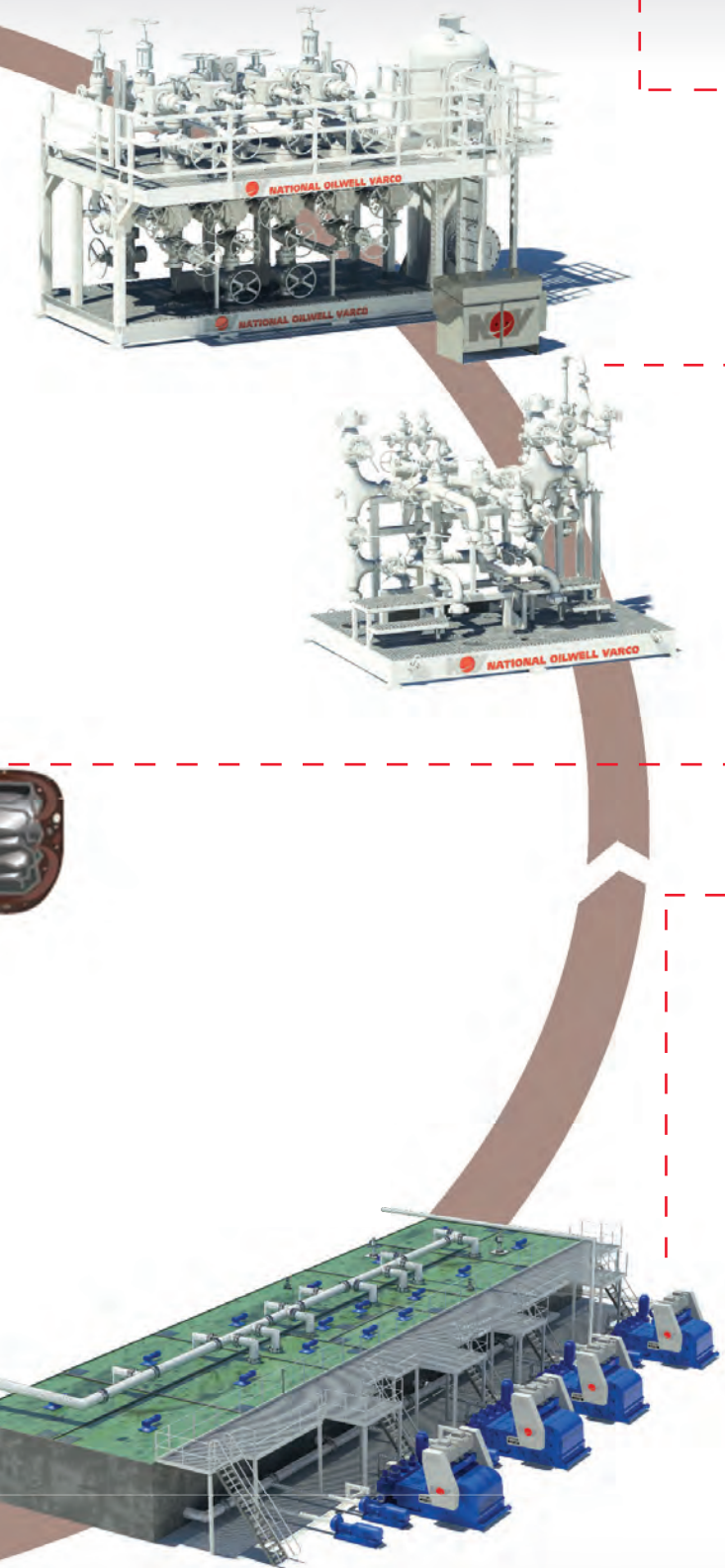

DRILLING FLUID CONTROL SYSTEM

Control System including:

State-of-the-art PLC controlled system which typically consists of dual screen operator stations for Control Room Environment. Industrial operator stations for safe or hazardous areas (Zone 1 or 2). Local control panels and I/O Cabinets for safe and/or hazardous areas.

Main Features:

The National Oilwell Varco® Drilling Fluid Control System monitors and controls:

- Barite, bentonite and cement bulk system
- Mud additive system with different options of feeding from Surge Tank Cell Feeders, Sack Handling Units and Big Bag Units
- LP Mud System
- Mud Storage System
- Mud Treatment
- Solids Control



Health, Safety and Environment (HSE)

Operator will benefit from remote operation and the listed automated functions. Use of this system significantly improves HSE by:

- Improved process control
- Reduced exposure to hazardous materials
- Reduced exposure to high noise levels, dust, and fumes during mixing and operation
- Reduced manual operation eliminates human failure and avoids risk of overfilling and settling
- Significant reduction of manual handling
- Automated operation and line-up of valves reduces amount of material spillage and contamination
- Simultaneous operations means increased efficiency and flexibility

An NOV® Drilling Fluid Control System significantly improves HSE.

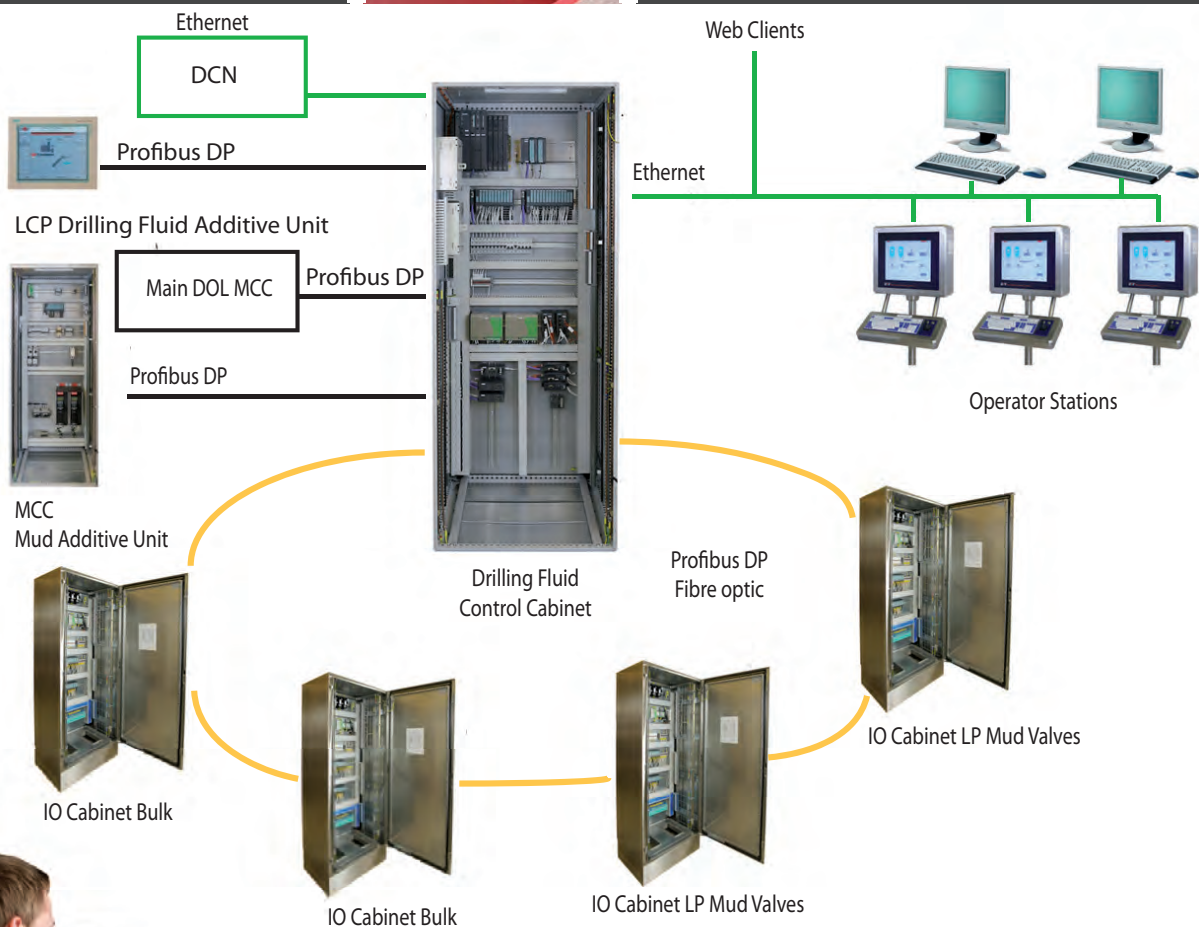

BULK STORAGE AND TRANSFER

- Process overview and weight monitoring of tanks
- Automatic refill of surge tanks
- Automatic valve line-up between loading stations/ bulk tanks
- Automatic emptying of dust collectors
- Heave and Tilt compensation of bulk tanks

**MIX / ADDITIVE**

- Process overview
- Automatic feeding from Surge Tank Feeder (such as Density, Weigh Maintenance, Batch and Rate modes) Automated Hopper/Mixer
- Automatic feeding from Sack Cutting Unit
- Automatic feeding from Big Bag Emptying Unit
- Automatic feeding from Liquid Skid

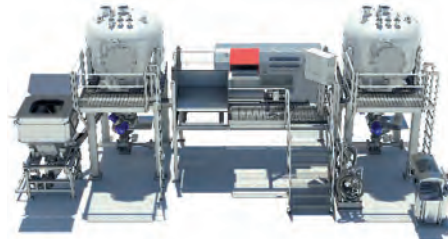
**STORAGE/PUMPING**

- Process overview/level monitoring with density
- Tank content labels
- Automatic valve line-up for mixing
- Automatic valve line-up for circulation
- Automatic transfer between tanks
- Automatic operation of agitators
- Tripping of LP pumps on level in batch mode
- Integrated operation of:
 - High pressure shear units
 - High rate mixers

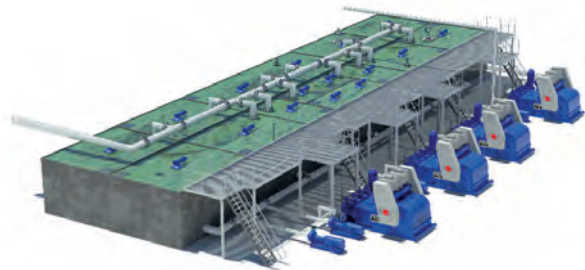
**HP MANIFOLD**

- Local and remote operation of gate valves and choke valves with back-up
- Local and remote monitoring of pressure, temperature and valve positions
- Remote monitoring of high pressure mud pumps

**SOLIDS CONTROL**

- Remote and automatic operation of Shale Shaker feed gate valves
- Remote operation of Degassers
- Remote operation of Cutting Screws, including auto sequences

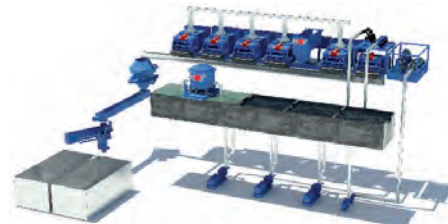
**WASTE MANAGEMENT**

- Local and Remote Process Control of Cuttings Handling
- Cuttings Re-Injection (CRI) system operates in a continuous process with the following automatic modes:
 - Automatic adding of seawater
 - Automatic adding of polymer
 - Automatic level control in coarse tank
 - Automatic transfer from fines tank
 - Automatic shaker control
 - Automatic mill control
 - Automatic viscosity control



SOLIDS CONTROL SYSTEM

VSM® Multi-Sizer® Separator

The VSM Multi-Sizer utilises a triple screen deck configuration enabling the operator to select either maximum capacity utilising same mesh screens on both primary decks, or alternatively by installing different mesh sizes on each deck. The unit has the ability to recover lost circulation material in advance of fine mesh solids removal using the Flex-Flow system. The VSM Multi-Sizer Separator is installed with Constant G-Control™ (CGC) Technology ensuring the unit operates at a constant 'G' irrespective of flow rates or solids loading ensuring maximum throughput.

“CGC increases shaker capacity by constantly measuring basket loading and adjusting g-force to optimize separation efficiency.”



VSM 300® Shaker

The VSM 300 has been purpose designed to provide a more efficient and cost effective, primary solids removal system, capable of coping with the demands of the drilling industry. The VSM 300 offers a number of flexible tools to deal with changes in drilling conditions including vibratory speed control, simple flow adjustment, and ultra-quick screen changing

“The VSM 300 is very reliable and an extremely simple machine to operate.”

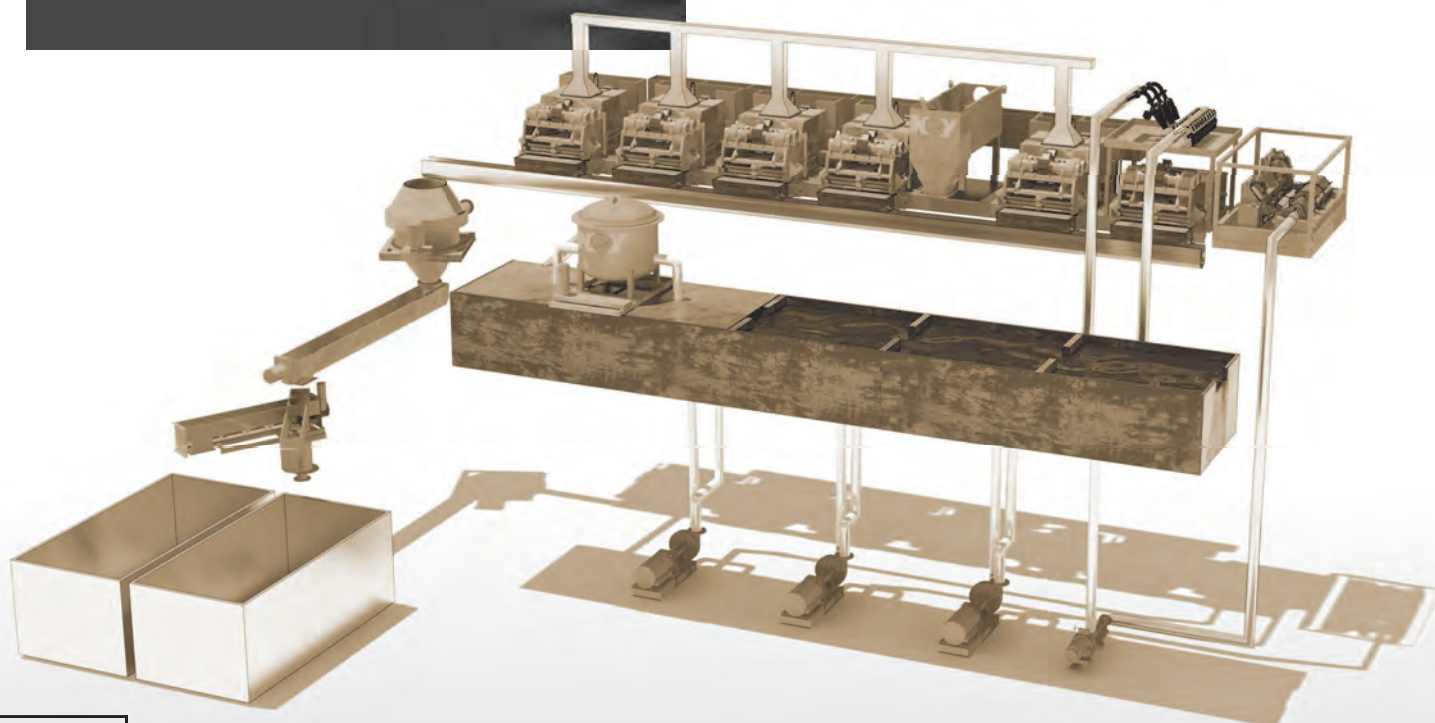
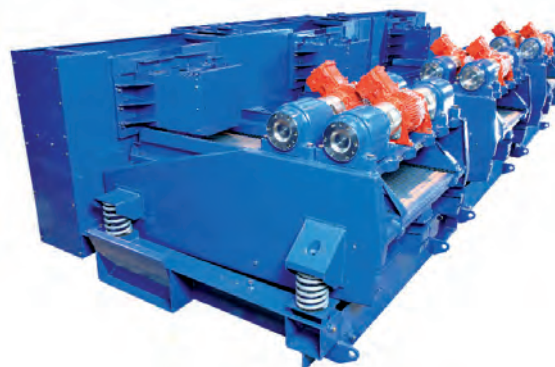



Desilter/Desander

All Brandt® 12” and 4” hydrocyclones are made from a durable polymeric material developed exclusively for NOV. These hydrocyclones offer high-temperature tolerance, greater resistance to erosion, and low-cost replacement. This design separates the solids more efficiently, saves valuable fluid, and reduces wear at the feed inlet. All 12” and 4” cones are mounted on rugged skids with a lifting eye to facilitate handling.

“They have preferred flange connections for tight, leak proof assembly.”



Gumbo Conveyor

The Brandt Gumbo Box can process high volumes of drilling fluid while removing gumbo and sticky clays that would blind other scalping units. The motor driven chain provides thousands of operating hours with reliable, maintenance free service.

“An optional integrated flow divider can be provided to feed up to eight shakers.”

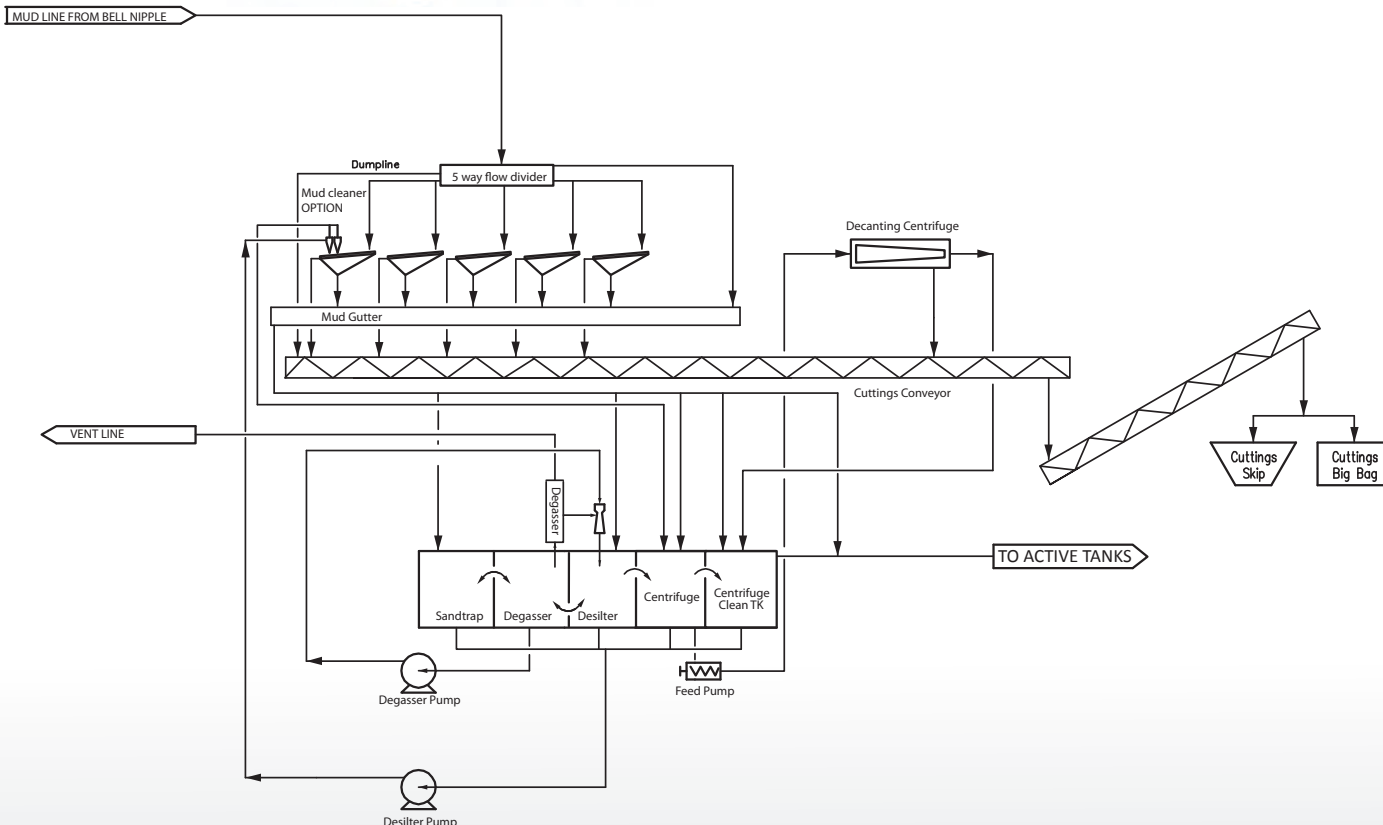

HIGH PRESSURE MANIFOLD SYSTEM

Choke and Kill Manifolds

- Typical pressure classes are 5,000 psi, 10,000 psi and 15,000 psi
- Includes High Pressure Piping and Blocks built to industry recognized codes and standards; typically ranging from 2" to 5".
- Certified for operation in hazardous areas
- Meets all relevant offshore requirements regarding health, safety, and environment

“Compact design”



Choke Control System - Local

- Easy to operate – intuitive layout
- System functions tailored to suit each project based on customer requirements
- Located adjacent to the Choke and Kill Manifold on the drill floor
- Can be covered with the lid to prevent dust and dirt on the gauges

“Tidy layout for easy maintenance.”



Choke Control System - Remote

- Simplified actuation of valve operations
- Readouts of pressure and temperature on all lines for Choke and Kill Manifold, Mud Gas Separator, Auxiliary and Primary Mud Standpipe Manifolds
- System interface accurately reflected in DCDA
- Alarm page with descriptive information
- Installed directly on the PLC cabinet in Drillers Cabin

“The flexible installation options are developed to optimize the clients working conditions.”



Mud Standpipe Manifolds

- Compact design
- Certified for operation in hazardous areas
- Meets all relevant offshore requirements regarding health, safety, and environment
- Field proven technology
- Layout based on customer requirements
- Custom designed skid structure available upon request

“Built with materials and surface treatments to withstand the roughest offshore conditions”



Cement Manifolds

National Oilwell Varco offers Cement Manifolds designed to suit all types of drilling installations including semis, drillships, fixed platforms, jackups and more. They are built to meet the offshore industry rules and regulations and customized to the client's specification.

“The manifold can be fitted on a complete skid with support framework.”

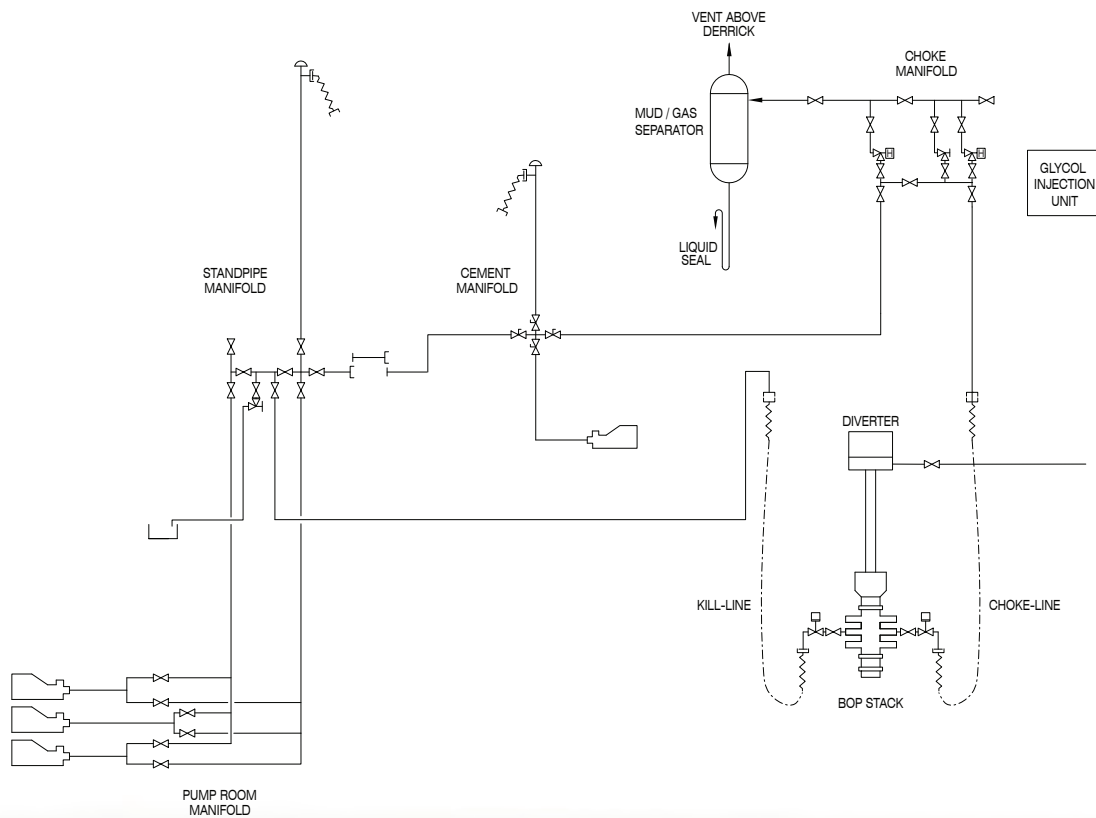

WASTE MANAGEMENT SYSTEM



Vortex® Dryer

NOV's Vortex Dryer reduces and recovers base fluid from a variety of feed slurries. In drilling operations, shale shakers can discard drilled cuttings that are up to 20% oil by weight. Treatment with the Vortex Dryer has proven to reduce this oil content dramatically, in some cases below 1%. It can also recover valuable base fluid for reuse and reduce solid waste volumes to curb transport cost. In addition it can meet environmental objectives or guidelines.

“Reduce fluid content on cuttings prior to disposal or further treatment.”



Brandt FreeFlow®

NOV's Brandt Positive Pressure Transport System provides a safe, compact method of transferring both wet and dried drill cuttings and can be used in conjunction with or to replace vacuum transfer systems, augers, cuttings pumps, or manual cuttings handling systems. The basic system components consist of the Air Conveyor and associated control system and the Slider Storage vessels can be utilised for storage if necessary.

“The system is safe, flexible, and efficient.”

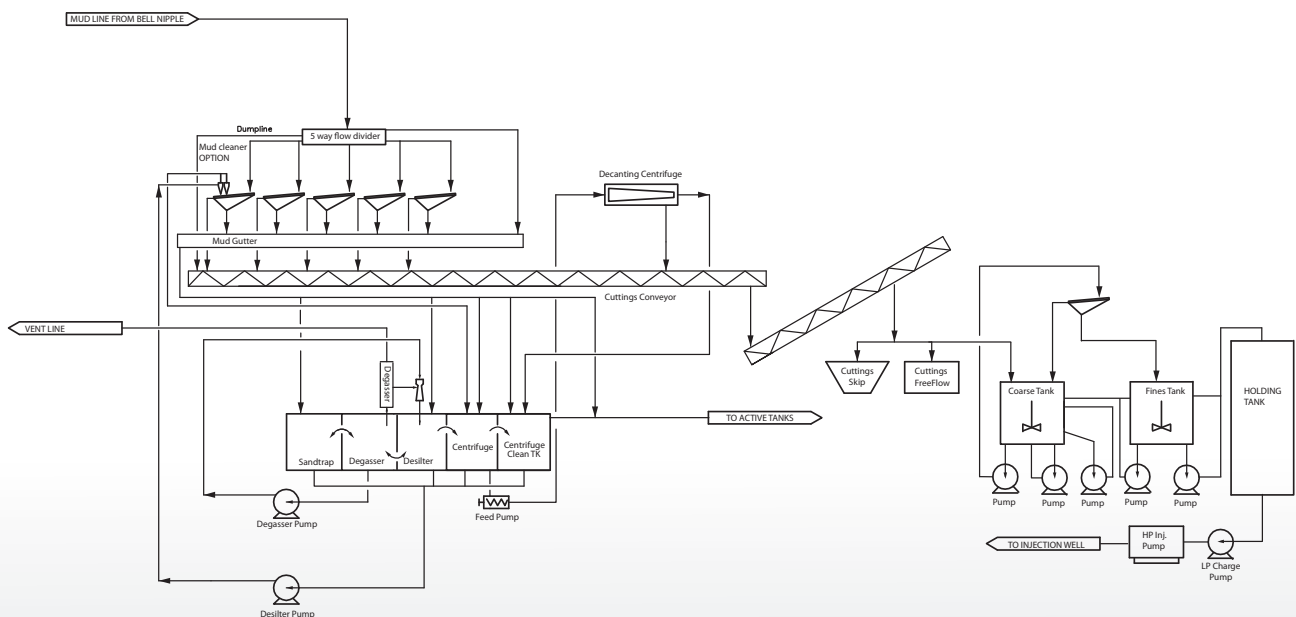

Features

Fifth generation design based on the SMACCC process (Statoil method for autogenously crushing and classifying of cuttings.)

- Field proven
- Modular – flexible footprint
- Certified according to required class
- Continuous process
- Controlled particle-size reduction and viscosity
- Low abrasion on injection equipment and well head
- Advanced process control which reduces the need for manual operations
- FluidControl has worldwide operational experience running the units and that we NOV can provide services to ensure successful execution of projects from cradle to grave.

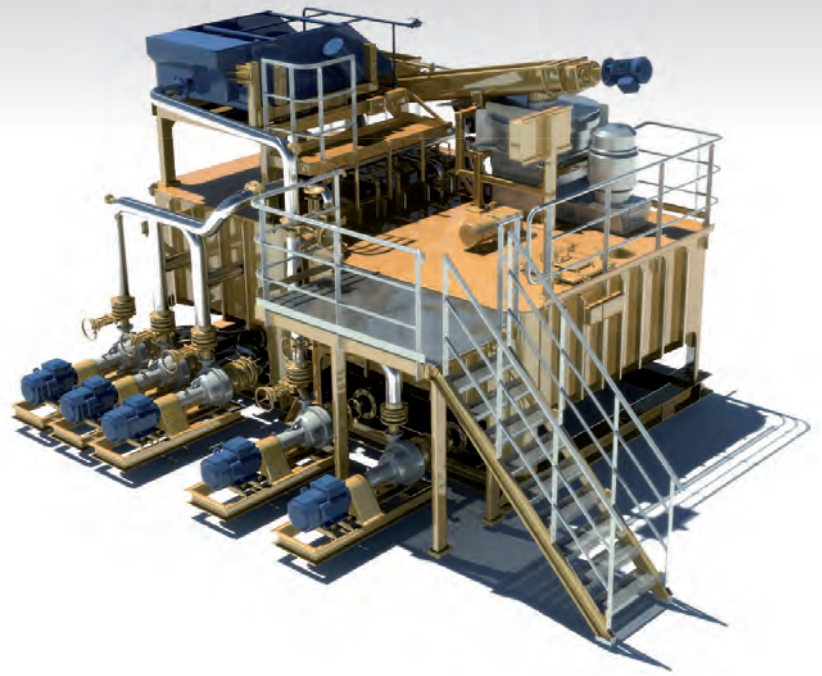

Procon Cuttings Re-Injection (CRI)

“ The Procon CRI system is field proven and has been in operation since 1991.

Currently there are more than 20 systems in operation, both on semi submersibles and fixed platforms.

The slurrification process is based on the patented SMACCC process.”



DRILLING FLUID STORAGE AND PUMPING SYSTEM

Triplex Mud Pump

NOV's Triplex Mud Pump is a single acting pump, and an outstanding addition to the "F" series Triplex Pumps. The pump's long stroke permits a slower speed, thus extending the unit's expendable life while still achieving maximum volume output.

“Designed and constructed for optimum performance and reliability under severe drilling conditions.”

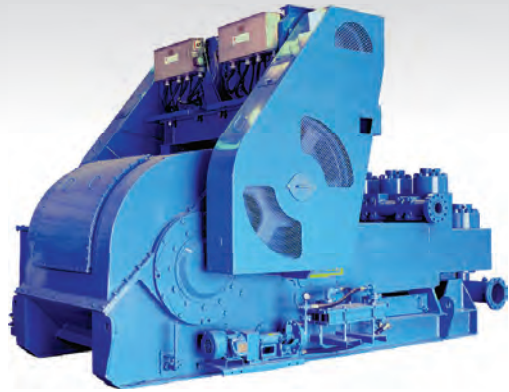

Hex Pump

NOV's latest development for improving circulating capability, the HEX[®] Pump represents years of knowledge and experience combined with a new approach to mud pump design. This new technology delivers improved performance, versatility, and efficiency in a smaller package.

“The HEX Pump is designed to satisfy the growing demand for hydraulic circulating power.”

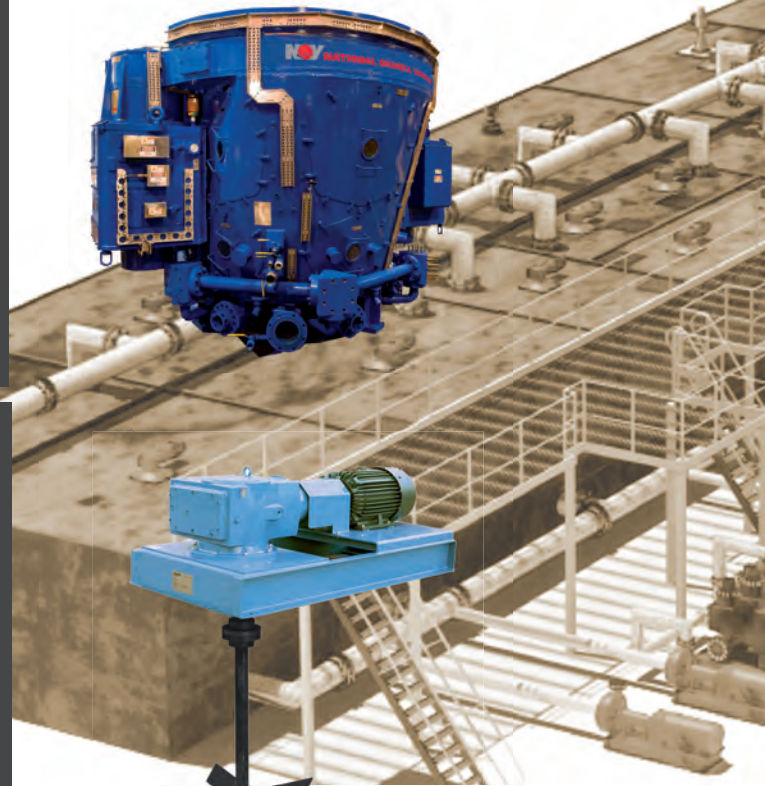

Agitator

NOV Brandt agitators serve the drilling industry with quality, time-proven mechanical agitation. The Brandt horizontally mounted MA-RG series agitator has been the industry standard for many years. Its rugged design, simplicity and dependability have made it the preferred choice of a majority of operators and contractors. The low profile of NOV horizontal agitators reduce headroom requirements.

“Designed and constructed to be efficient and reliable.”



Centrifugal Pump

NOV's line of Mission Magnum[®] Centrifugal Pumps is proven as reliable, heavy duty, low cost slurry pumps. By utilizing the same power end, these pumps can be provided at a low cost, and customer's spare parts inventory requirements are greatly reduced.

“These pumps have been world leaders in the drilling industry since their inception in the 1970s.”





High Rate Mixer

NOV's High Rate Mixer is the most efficient solution for high capacity mixing of barite into the drilling fluid. An integrated "in-line mixer" and an air diluter prevent emissions.

“ Barite is transferred directly from the bulk storage tank and mixed into the dedicated mud pit.”

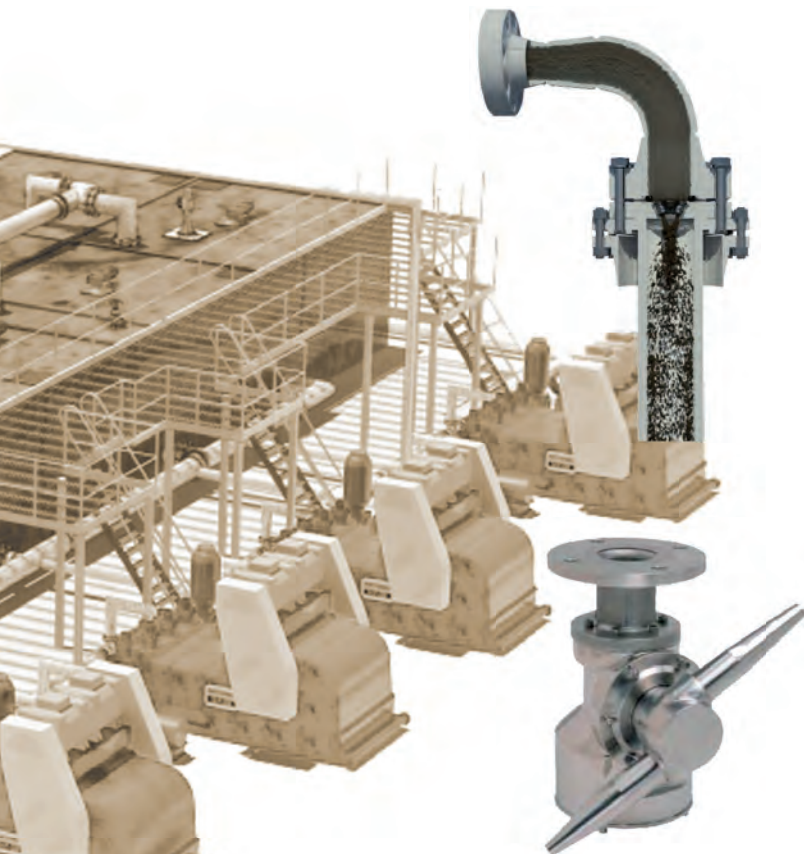

High Pressure Mud Shear Unit

This Procon High Pressure Shear Unit allows fast hydration and mixing of chemicals which are normally slow to dissolve, chemicals such as bentonite, polymers and lignite. The chemicals are mixed via the sack cutting unit or surge tank into the predefined pit with a "HP Shear Unit" installed. Suction is then taken from the designated pit, through a low pressure mud line to a super charge pump and high pressure mud pump.

“ This system is ideal for pre-hydrating bentonite and for mixing premix mud.”

Tank Cleaning System

NOV's Rig Cleaning system is based on a recirculating ring-main system using surfactant treated wash water. The wash water is pumped from the main processing unit and is circulated to any part of the rig that would require regular cleaning or retrieval of slop waste and is then returned to the processing unit.

“ The flow of the cleaning fluid makes the nozzles perform a geared rotation around the vertical and horizontal axis.”

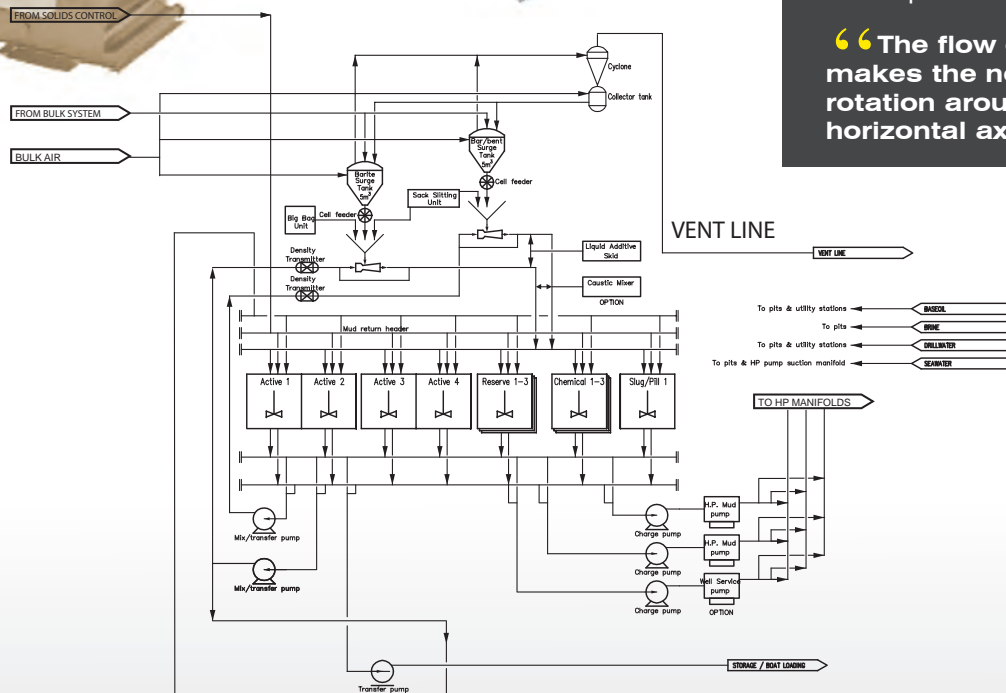

DRILLING FLUID MIX / ADDITIVE SYSTEM



Surge Tank Feeder

NOV's Surge Tank is the optimal solution for receiving dry bulk materials and feeding it into a mixing system. Both refill of the tank and replenishing through the feeder can be fully automated. This provides the operator with the needed flexibility for local or remote operation. With the optional "loss in weight" function, a controlled rate can be ensured during refill of the tank.

“Controlled and accurate feeding of dry bulk material.”



Sack Cutting Unit

The new Sack Cutting Unit by NOV is specifically designed to empty different types of sacks with mud additive chemicals. The NOV Sack Cutting Unit operates by cutting the sack, separating the contents from the wrapping, compressing the empty wrapping into a waste bag and feeding the chemicals at the desired rate into the drilling fluid.

“The unit provides a healthy and ergonomically correct workplace for the operator.”

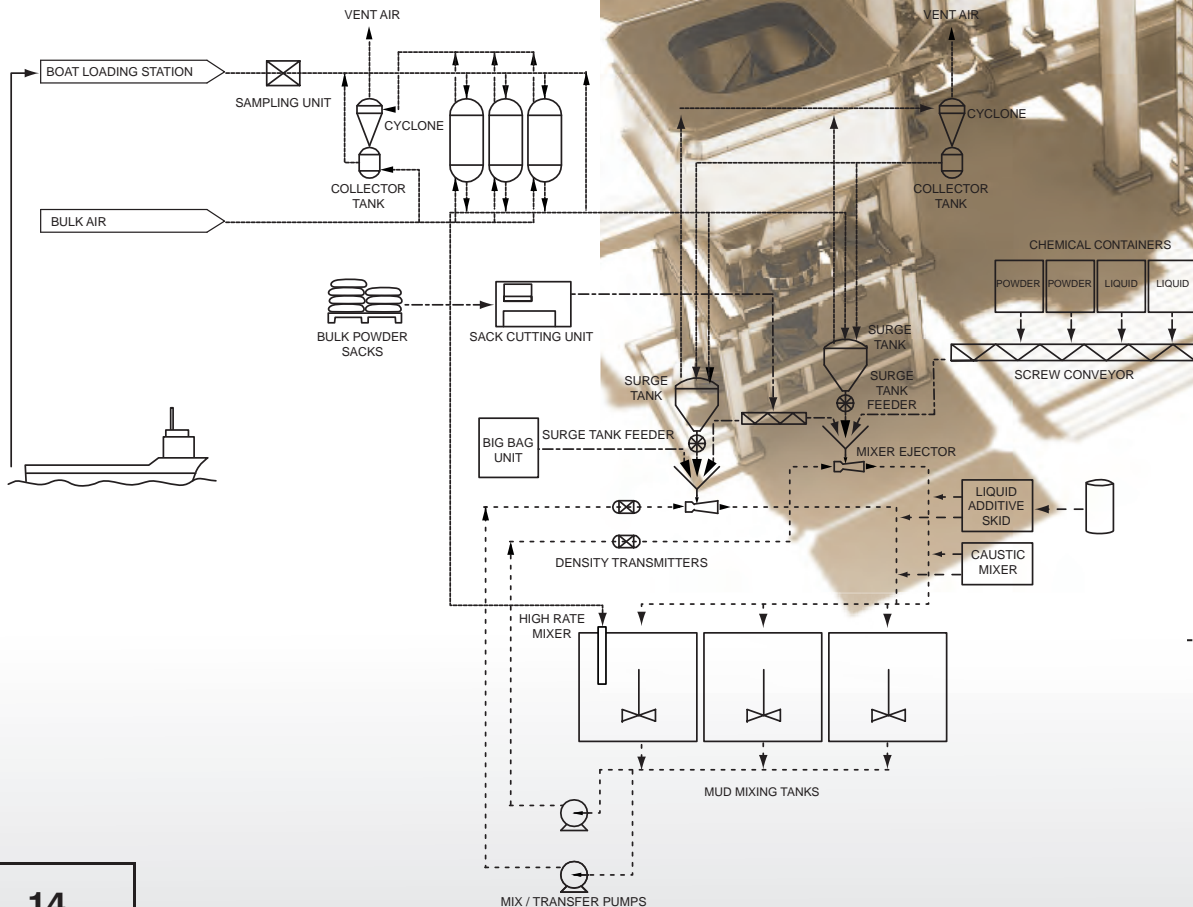

Liquid Additive Unit

NOV's Liquid Additive Skid is a simple, safe solution for adding liquid chemicals from barrels or containers directly into the drilling fluid mix line. This compact unit is fully self-contained, with manual controls and electronic instrumentation for monitoring pump speed. As an option, the Liquid Additive Skid can be fully automated and remote controlled for full operational flexibility.

“Handles all normal liquid chemicals, including high viscosity fluids.”



Mud Venturi Mixer/Hopper

NOV's Mud Mixer/Hopper is specifically designed to be the optimal solution for mixing dry powder chemicals into the drilling fluid. The unit has an optional plenum chamber to collect material flow from different sources, such as the surge tank, sack cutting unit and manual sack table.

“Complete “dust-free” mixing of materials from surge tank.”



Caustic Mixer Unit

NOV's Caustic Mixer is designed to provide a safe and efficient means of preparing caustic fluid and injecting it into the mud stream. Caustic powder in sacks is taken into the handling enclosure for emptying. The powder falls into the water in the tank below, and the remaining wrapping is disposed of in a plastic waste bag. Therefore, physical contact with the caustic material is prevented.

“Automatic opening of bags in a safety enclosure, preventing physical contact with materials.”



Big Bag Emptying Unit

NOV's Big Bag Unit with dust filter is specifically designed for emptying various types of big bags into the drilling fluid at desired rate.

“Integrated dust filter with “reverse jet cleaning” ”



BULK STORAGE AND TRANSFER SYSTEM

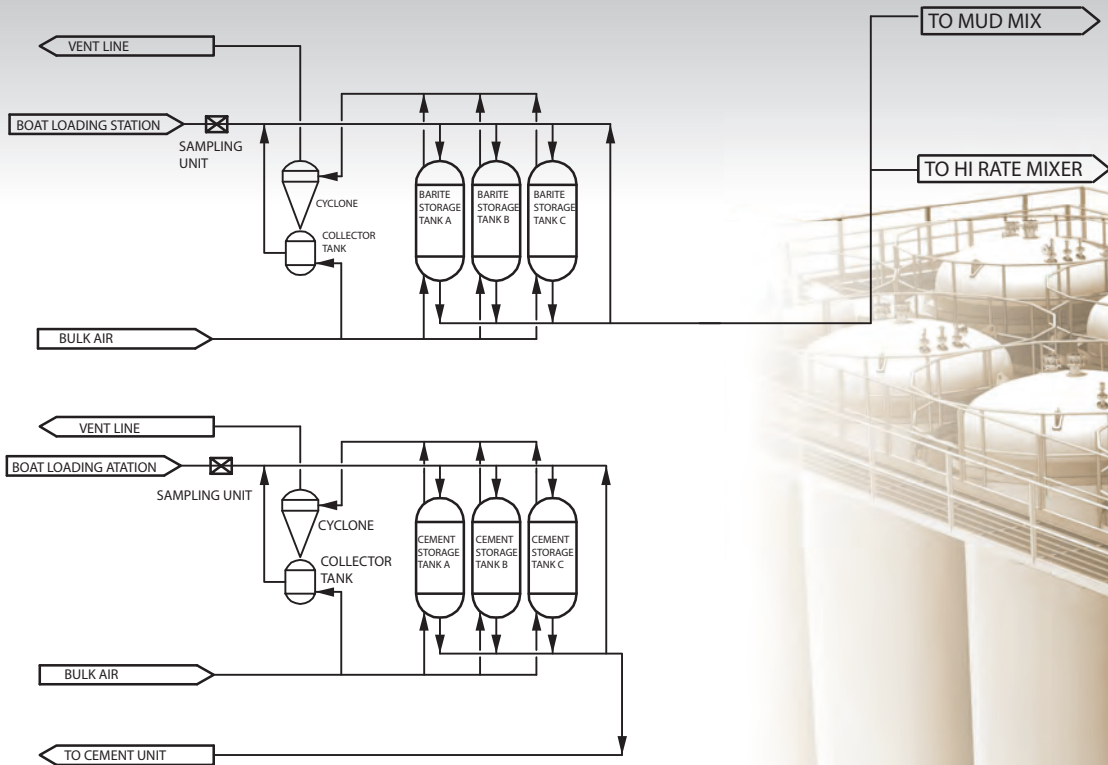

Bulk Storage Tank

NOV's Bulk Storage Tank is the optimal solution for storage and transfer of dry bulk materials. Its unique internal fluidization system ensures thorough emptying and optimized transfer rates. Electronic weight, pressure and level sensors are utilized for process monitoring and control. Both the filling and emptying of the tank can be fully automated, providing the operator with the flexibility for local or remote operation.

Features:

- Dust-free handling of bulk materials
- State-of-the-art PLC control system which enables control of the entire bulk storage and transfer process as an option
- Highly accurate weighing system by load cells. Can be heave and tilt compensated for correct readings during external accelerations
- Available in numerous sizes or custom made to fit available space
- Spherically shaped bottom available for weight and height reduction
- Can be supplied with all relevant class and code certificates
- Suitable for offshore installation and floating rigs

“The compact design of the Bulk Storage Tank reduce the need for installation space.”



Dust Cyclone and Collector

NOV's Dust Cyclone and Collector is the optimal solution for separating dust particles from the ventilation air at a pneumatic dry bulk transfer system. The unit works continuously during a transfer, collecting the powder particles in the collector tank while evacuating the "clean" air to a designated area.

“The emptying of the collector tank can be fully automated.”

Surge Tank with Feeder

NOV's Surge Tank is the optimal solution for receiving dry bulk materials and dosing it into a mixing system. Both refill of the tank and dosing through the feeder can be fully automated. This provides the operator with the needed flexibility for local or remote operation. With the optional "loss in weight" function, a controlled dosing can be ensured during refill of the tank.

“A controlled and accurate feeding of dry bulk material.”

Loading Station

National Oilwell Varco's new generation of Hose Reel Stations is designed for the transfer of liquid and dry bulk materials between supply vessel and platform. This system improves safety, minimizes the risk of pollution and extends the life span of the hoses. The range of Hose Reel Stations supplied by National Oilwell Varco includes single- and multi-reel applications for new or existing offshore installations.

“The system is designed, produced, tested and certified according to authority rules and regulations.”

Rock Catcher

Large objects are either crushed against the mesh or collected for easy removal.

- Meets all relevant offshore requirements regarding health, safety and environment
- Complete enclosed unit
- Field proven technology

“NOV's Rock Catcher is designed to prevent rocks or large objects to be transferred through the dry bulk transfer lines which can cause damage to equipment and pipelines.”



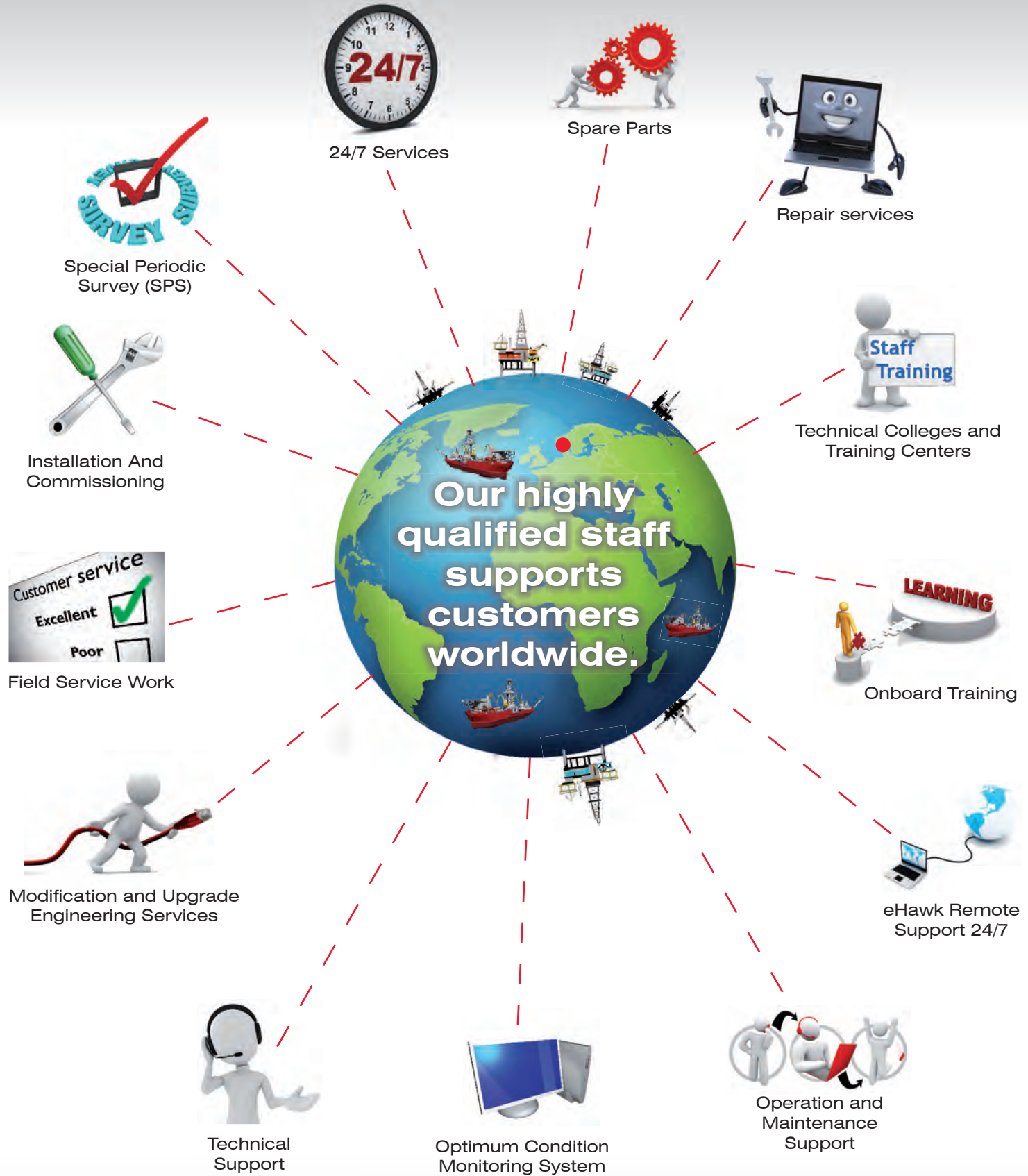

Aftermarket

Aftermarket is NOV's customer support organization. As an Original Equipment Manufacturer (OEM), NOV provides comprehensive service solutions and assistance to our customers in order to support the lifetime of your equipment, through an integrated network of facilities world wide.



Before modification

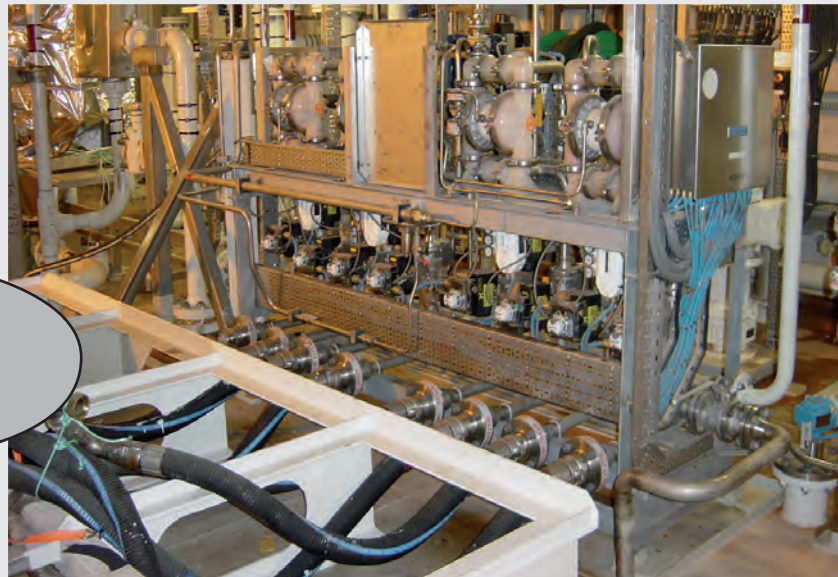

After modification

NOV's Aftermarket Field Engineering Group

can do modifications to the complete Drilling Fluid System such as:

- Redesign of layout into existing available space.
- Replace worn out equipment with new machines
- Optimize functionality and calculate processes
- Upgrade old Control Systems to latest revision, e.g. HMI- and PLC- systems

Typically upgrades are:

- Complete mix and additive system
- Control system upgrades (panels, operator's stations, new functions, etc.)
- All sorts of Choke and Kill manifold and control system upgrades

“NOV's multidiscipline engineering and process knowledge will ensure client needs are taken care of for the complete drilling fluid system.”

Corporate Headquarters

7909 Parkwood Circle Drive
Houston, Texas 77036
United States
Phone: 713 375 3700
Fax: 713 346 7687

Rig Solutions

10000 Richmond Avenue
Houston, Texas 77042
United States
Phone: 713 346 7500
Fax: 713 435 2195

For a complete list of NOV's Rig Solutions locations, visit us online:

www.nov.com/RigSolutionsLocations

National Oilwell Varco has produced this brochure for general information only, and it is not intended for design purposes. Although every effort has been made to maintain the accuracy and reliability of its contents, National Oilwell Varco in no way assumes responsibility for liability for any loss, damage or injury resulting from the use of information and data herein. All applications for the material described are at the user's risk and are the user's responsibility. All brands listed are trademarks of National Oilwell Varco.



One Company . . . Unlimited Solutions

corporatemarketing@nov.com

Downhole Solutions

Drilling Solutions

Engineering and Project Management Solutions

Industrial Solutions

Lifting and Handling Solutions

Production Solutions

Supply Chain Solutions

Tubular and Corrosion Control Solutions

Well Service and Completion Solutions

www.nov.com