

Lifting & Handling product portfolio





Customer confidence rooted in a legacy of experience.



Your partner for a lifetime of lifting.

The depth of our experience and dedication to our customers empowers you to meet your challenges head on. We build upon a long legacy of proven equipment to design new products that are easy to own, operate, and maintain – without sacrificing performance.

This portfolio focuses primarily on our standard models. Tailored solutions can also be provided for the equipment families described.

The results you came to expect from National, Unit Mariner, Stålprodukter, Hydralift, Dreco, Lucker, Hepburn, McElroy, Fritz Culver, Sauerman, AmClyde, Norson, and Remacut are deeply rooted at NOV.

Offshore cranes	pg. 3-8
Subsea cranes	pg. 9-14
Heavy lift cranes	pg. 15-18
Other cranes	pg. 19-22
Pipe lay equipment	pg. 23-40
Other products	pg. 41-48
Aftermarket services	pg. 49-54
Equipment packages	pg. 55-58



Offshore cranes

Designed to withstand the impact of harsh conditions, NOV offshore cranes are crucial to the daily operations of hundreds of platforms and vessels worldwide. We have a large range of standard offshore crane models that have been refined through decades of field experience and performance feedback. When a custom crane is needed, the same expertise is put to use to ensure that we deliver a tailored solution that can be relied upon.

55 t OCL crane located on Oseberg A

Unit cranes



Primary function: offshore construction
Capacity range: 20-60 t

Unit cranes are designed as a simple solution to shallow water production and drilling operations. They are easy to maintain, easy to operate, and have a low weight compared to their lifting capacities. Unit cranes can be equipped with computer/video equipment to provide improved load control and crane diagnostics. Configurations are available as diesel/hydraulic or electro/hydraulic.

Technical specifications of standard models

Crane model	Max overturning moment (kNm)*	Radius (m)	Max SWL (t) main	Max SWL (t) whip	Weight (t)
Unit 5,500 HD	4,500	5.4 - 31.8	38.3 @ 5.4 m	4.9 @ 30 m	29
Unit 10,000 HD	10,000	5.7 - 37.8	50 @ 10 m	6.8 (all radii)	49
Unit 20,000 HD	16,500	6.1 - 38.4	59.4 @ 8.2 m	9 (all radii)	89
Unit 35,000 HD	31,162	6.79 - 62.8	88.7 @ 12 m	9 (all radii)	112.78

*Max overturning moment shows design loads on top of the pedestal (DNV)

OCB cranes



Primary function: offshore cargo handling
Capacity range: 10-100 t

The ram cylinder box boom crane is the most economical crane in the low end of the capacity range. The crane has a low center of gravity and can operate within a very short working radius. Adding one or more telescopic boom sections can extend the cranes outreach without affecting its compact footprint

Technical specifications of standard models

Crane model	Max overturning moment (kNm)*	Radius (m)	Max SWL (t) main	Max SWL (t) whip	Weight (t)
OC1891B	5,200	3 - 15	15 @ 15 m	NA	29
OC2809B	15,000	4.5 - 35	30 @ 20 m	Optional	55
OC3449B	27,000	7 - 45	30 @ 28 m	Optional	98

*Max overturning moment shows design loads on top of the pedestal (DNV)

OCL cranes

Primary function: offshore cargo handling
Capacity range: 10-300 t

The OCL lattice boom cranes are optimized for sea-lifts from support vessels and provide excellent capacity at long radii with fast crane movements and high accuracy. The cranes can be delivered in electric/hydraulic, diesel/hydraulic or all electric prime driver configurations. All electric versions also have optional battery banks – for applications where power availability is restricted.



Technical specifications of standard models

Crane model	Max overturning moment (kNm)*	Radius (m)	Max SWL (t) main	Max SWL (t) whip	Weight (t)
OCL 1800	10,000	4.5 - 35	45 @ 10.5 m	7.5 @ 35 m	58
OCL 2400	18,500	5.5 - 45	65 @ 12 m	10 @ 45 m	87
OCL 3050	31,500	6 - 55	100 @ 12 m	16.5 @ 55 m	114
OCL 3550	45,000	8 - 70	150 @ 14 m	20 @ 56 m	135
OCL 4300	70,000	45 - 80	300 @ 15 m	25 @ 60m	200

*Max overturning moment shows design loads on top of the pedestal (DNV)



50 t crane on Statfjord B

OCK cranes



Primary function: offshore cargo handling
Capacity range: 10-100 t

The cylinder-luffed knuckle boom cranes were designed for the challenges associated with offshore applications; moving vessels, space limitations and harsh environments. The cranes have low centers of gravity, and the knuckle boom design provides superior control of free-hanging loads. This crane offers an excellent compromise between control of internal material transfer and handling cargo to and from supply-vessels.

Technical specifications of standard models

Crane model	Max overturning moment (kNm)*	Radius (m)	Max SWL (t) main	Max SWL (t) whip	Weight (t)
OC2401K	9,000	3.8 - 25	28 @ 13 m	Optional	45
OC2809K	15,000	6 - 35	30 @ 18 m	Optional	60
OC3449K	27,000	7.5 - 45	30 @ 26 m	Optional	105
OC3932K	38,000	9 - 50	45 @ 20 m	Optional	153
OC3932K	51,563	7.3 - 42	85 @ 18.5 m	NA	145
OC4000K	61,150	8 - 45.3	100 @ 20 m	NA	167

*Max overturning moment shows design loads on top of the pedestal (DNV)



OCK-K crane on Noble Tom Madden

MSB cranes

Primary function: offshore construction
Capacity range: 450-1,500 t

The MSB series are construction cranes designed for surface construction projects. Capacities go up to 1,500 t and operating radii can be more than 100 meters. These cranes give an excellent balance of safe working load vs. reach, and are delivered with either all-electric or electric/hydraulic prime drive system.



Technical specifications of standard models

Crane model	Max overturning moment (kNm)*	Radius (m)	Max SWL (t) main	Max SWL (t) whip	Weight (t)
MSB 5000	122,000	10.0 - 62	400 @ 28 m	36 (all radii)	404
MSB 6000	190,000	10.8 - 82	600 @ 29 m	36 (all radii)	502
MSB 7000	261,000	11.2 - 100	1,000 @ 23 m	100 (all radii)	657
MSB 7600	422,000	12.2 - 114	1,500 @ 25 m	100 (all radii)	859

*Max overturning moment shows design loads on top of the pedestal (DNV)



900 t MSB-S crane on Normand Maximus | Photo courtesy of: Harald M. Valderhaug

Subsea cranes

We provide a broad range of subsea cranes for a variety of applications in oil and gas, and renewables. All of our subsea cranes delivered with a multilayer Active Heave Compensation (AHC) winch system can be equipped with a Kinetic Energy Recovery System (KERS) that recover system energy from vessel rising and block lowering while in active heave compensation mode.

350 t and 50 t OCKS cranes on Far Sleipner



Trident™ cranes

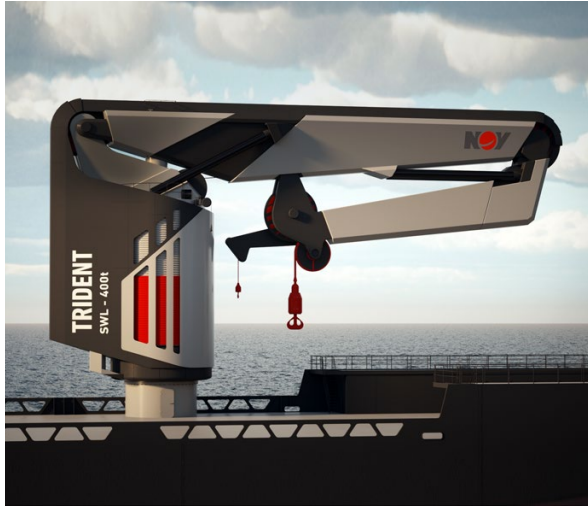

Primary function: subsea construction
Capacity range: 70-400 t

The Trident crane is designed to use fiber rope which eliminates the loss of capacity for subsea lifts and wire corrosion issues. The large diameter horizontal AHC pedestal winch system accommodates for smooth handling of the fiber rope and it is also a more environmentally friendly option as the fiber rope does not need to be greased. The crane can be configured to operate at any depth, and through a rope monitoring system, the status of the fiber rope is always known. Though the crane is designed for fiber rope, customers still have the option of using both steel wire and hybrid ropes as well. The crane driver operates the crane from a remote Lifting Operation Station (LOS) typically placed on the vessel bridge – thus becoming an integrated member of the vessel crew.

Technical specifications of standard models

Crane model ⁽¹⁾	Max overturning moment (kNm) ⁽²⁾	Radius (m)	Max SWL (t) main ⁽⁴⁾	Max SWL (t) whip	Weight (t) ⁽⁵⁾
TRI75	21,500	5 - 30	75 @ 11 m	10 @ 32 m	250
TRI100	29,500	6 - 30	100 @ 12 m	10 @ 35 m	310
TRI150	47,000	7 - 33	150 @ 14 m	10 @ 35 m	390
TRI165 ⁽³⁾	72,000	7 - 50	165 @ 17 m	10 @ 52 m	535
TRI250	101,000	7 - 36	250 @ 18 m	20 @ 38 m	575
TRI400	147,000	9 - 40	400 @ 16 m	40 @ 42 m	797

(1) 3000 m model (available 3660 & 4000 m)
 (2) DNV rated
 (3) 3660 m model

(4) Subsea lift
 (5) Fiber rope included



OCK-S cranes

Primary function: subsea construction
Capacity range: 15-800 t

OCK-S are knuckle boom subsea cranes equipped with a multilayer AHC winch, either located on the crane or below deck. The knuckle boom design provides superior control of free-hanging loads which ensures that the load can be handled safely between vessel deck and off-board lowering position, even in situations where the vessel is in motion. The cranes are very compact and have a low center of gravity.



Technical specifications of standard models

Crane model	Max overturning moment (kNm)*	Radius (m)	Max SWL (t) main	Max SWL (t) whip	Weight (t)	Std. wire length (m)
OCKS 2201	6,037	5 - 20	15 @ 20 m	NA	40	3,000
OCKS 2809	13,333	4 - 21	50 @ 16 m	10 @ 21 m	175	3,000
OCKS 3426	20,760	6 - 26	70 @ 19 m	10 @ 26m	208	3,000
OCKS 3449A	28,500	6.5 - 29	100 @ 16 m	20 @ 29 m	265	3,000
OCKS 3449B	28,500	7.5 - 32	125 @ 13 m	10 @ 32 m	301	3,000
OCKS 3932	37,000	7 - 32	150 @ 14.5 m	10 @ 32 m	351	3,000
OCKS 4475	78,737	8 - 50	165 @ 18 m	20 @ 50 m	525	3,660
OCKS 4000	44,745	7 - 33	200 @ 15.5 m	10 @ 33 m	417	3,000
OCKS 4475A	72,800	8.5 - 40	250 @ 17 m	20 @ 40 m	583	3,000
OCKS 4475B**	74,429	8 - 40	250 @ 15 m	20 @ 40 m	629	3,000
OCKS 4500**	110,000	8 - 40	250 @ 18 m	20 @ 40 m	724	3,000
OCKS 5000**	140,890	10 - 43	400 @ 19 m	20 @ 43 m	1,021	3,000

*Max overturning moment shows design loads on top of the pedestal (DNV)

** Main winch below deck

OCB-S cranes

Primary function: subsea construction
Capacity range: 15-800 t

The ram cylinder luffing box boom subsea crane is a cost efficient alternative to subsea knuckle boom or subsea lattice boom cranes. The crane has a low center of gravity and the design is efficient at short radii. To provide flexibility, one or more telescopic boom section can be added without affecting the footprint of the crane. The crane is normally equipped with AHC winch.



MSB-S cranes



Primary function: subsea construction
Capacity range: 600-1,350 t

The MSBS series are construction cranes designed for subsea construction projects. The cranes AHC winch system is installed under deck. The AHC winch system is available in either a “traction and compensator” type or multilayer AHC winch. Extended boom lengths are available to provide high capacity and long reach.

Technical specifications of standard models

Crane model	Max overturning moment (kNm)*	Radius (m)	Max SWL (t) main	Max SWL (t) whip	Weight (t)	Std. wire length (m)
MSB-S 6000	194,000	12.6 – 70.0	600 @ 28 m	36 (all radii)	1,215	3,000
MSB-S 7000	230,000	15.3 – 75.0	900 @ 22.5 m	100 (all radii)	1,548	3,000
MSB-S 7600	426,000	16.0 – 85.0	1,200 @ 30 m	100 (all radii)	1,867	3,000

*Max overturning moment shows design loads on top of the pedestal (DNV)



A - MSB Crane on Normand Maximus B - 250 t OCKS crane on Siem Daya 1 C - 400 t OCKS crane on Normand Clipper



Heavy lift cranes

Our heavy lift (HL) cranes have a lifting capacity of 1,000 t and above. They are primarily designed for offshore construction with active heave compensated hoist arrangements available for deep water lowering. Special configurations are also available for windmill installation.

4,200 t HLA crane on DLS-4200



Heavy lift post cranes



Primary function: heavy construction
Capacity range: 1,000-3,000 t

The Heavy Lift Post cranes (HLP) are the preferred choice in its range when deck-space is the critical factor and the crane needs to be able to pick up loads close to the base. The post cranes are available with different configurations that offer continuous rotation and a trolley for light and precise load movements. The cranes can be delivered in modules for efficient installation and the electrical drives and mechanical layout can be customized to fit any vessel.

Technical specifications of standard models

Crane model	Max overturning moment (kNm)	Radius (m)	Max SWL (t) main	Max SWL (t) whip	Weight (t)	Std. wire length (m)
HLP 1200	636,000	15 - 92	1,200	350	1,519	2 @ 1,470
HLP 3000	1,139,000	18 - 95	2,722	400	1,950	2 @ 3,016

Heavy lift A-frame cranes



Primary function: heavy construction
Capacity range: 1,000-10,000 t

By using a flexible A-frame design, Heavy Lift A-frame cranes (HLA) are the most cost efficient designs to meet special customer requirements. The slewing system would generally be a container ring, but for smaller cranes, a slew bearing is also an option. HLA cranes can be delivered with a tie-back option, providing up to 25% more capacity than the base configuration, and an A-frame lowering system for low-height transportation mode.

Technical specifications of standard models

Crane model	Max overturning moment (kNm)	Radius (m)	Max SWL (t) main	Max SWL (t) whip	Weight (t)	Std. wire length (m)
HLA 2000	780,000	20 - 75	2,000	600	250	2,200
HLA 3000	1,300,000	22 - 78	3,000	675	50	2,900
HLA 5000	2,490,000	25 - 80	5,000*	1,000	175	4,800

*Tailored HLA designs can be offered as engineered to order cranes up to 10,000 t

Around the leg cranes

Primary function: surface construction
Capacity range: 200-2,500 t

Our Around The Leg cranes (ATL) are tailored to fit specific liftboat or jackup specifications. For decades we have applied our experience designing and manufacturing these cranes for the offshore construction industry and have optimized our designs to provide maximum strength while maintaining minimal weight. Special attention is paid to specific application requirements as well as designing the crane for excellent serviceability.



2 x 7000 t HLA cranes on Saipem 7000

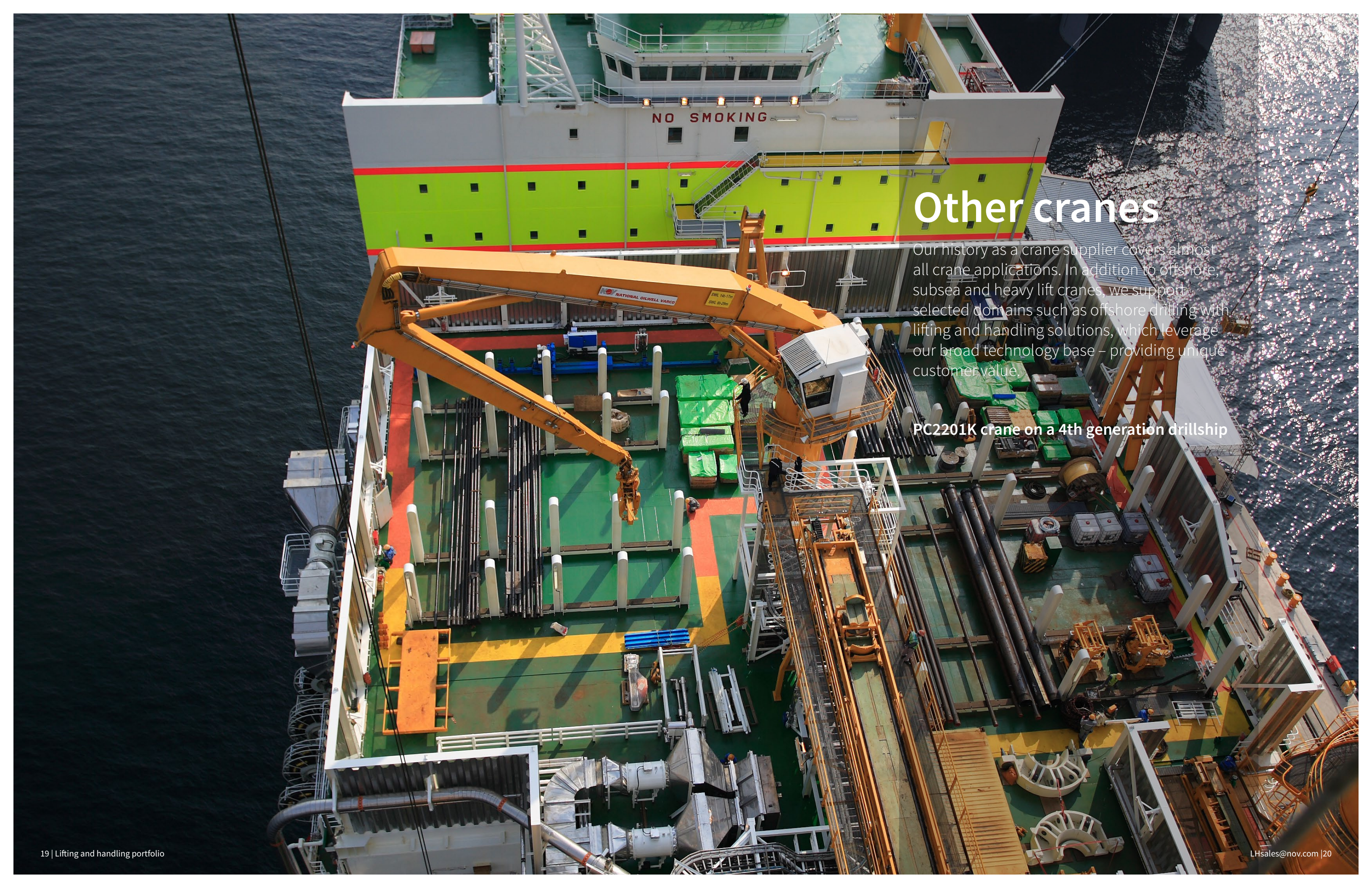

Other cranes

Our history as a crane supplier covers almost all crane applications. In addition to offshore subsea and heavy lift cranes, we support selected domains such as offshore drilling with lifting and handling solutions, which leverage our broad technology base – providing unique customer value.

PC2201K crane on a 4th generation drillship

Land slew bearing cranes



Primary function: quayside cargo handling
Capacity range: 50-450 t

Our LSB crane series has decades of proven field service in land applications - typically in harbor and shipyard environments. These cranes can be fixed quayside, placed on top of moving gantries, or used in dry dock applications. Our experience from the marine environment is conveyed into the design of the cranes, providing durability, low maintenance needs, and good serviceability.

Bulk handling cranes



Primary function: bulk handling
Capacity range: 60-140 t

With a proven history of high cycle, heavy-duty bulk material handling operations, our fully electric Bulk handling cranes allow you to work around-the-clock, loading and unloading your vessel with the highest efficiency.

A-frames

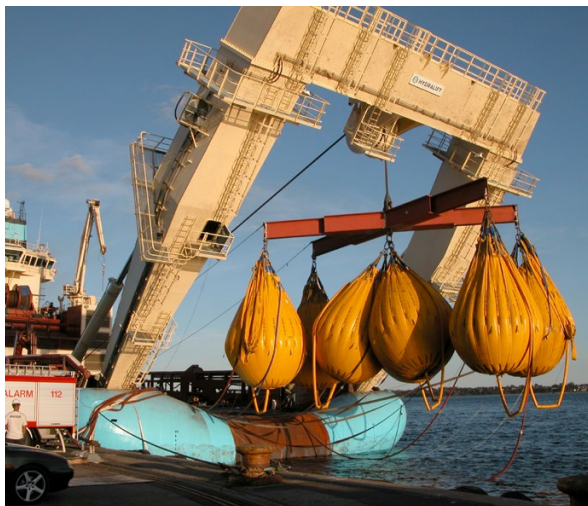

Primary function: construction
Capacity range: 10-350 t

A-frames are deck mounted, A-shaped box constructions with ram cylinders for luffing between inward and outward positions. The A-frame is designed for lifting operations on all types of vessels. It performs lifts from the vessel deck over the stern or over the side of the vessel, and is paired with a suitable winch package - based on application. In addition to the A-frame, we also provide winch and compensator system.

Pipe handling cranes

Primary function: drill pipe handling and pipe lay
Capacity range: 12-35 t

Pipe handling cranes (PC) are combined knuckle- and telescope cranes. They are designed for safe and effective handling of drill pipe, drill collar and casing between the pipe deck and the catwalk machine. The use of our specially designed gripper, magnetic or screen yokes ensure steady lifting and hands-free loading/unloading operations. A hook adapter enables handling of various equipment through the use of lifting slings.

Standard models

- PC1891K
- PC2201K
- PC2401K
- PC2809K
- PC3426K



Pipehandling Crane on Drillship



Lay equipment

With many years of experience delivering umbilical, flexible flowline, rigid pipe and cable lay systems under the Remacut, Norson and AmClyde brands, NOV has the expertise to ensure you get the right equipment on schedule and within budget.

70 t horizontal lay system, 400 t and 100 t OCKS crane on AMC connector

Newly combined capabilities

We are working closely with our customers to create an open dialog and learn more about your needs. We understand that you are faced with an environment that is constantly changing and maximizing your vessel utilization is more important now than ever. The newly combined capabilities of Remacut and NOV uniquely positions us to deliver a broad range of lay equipment and complete lay systems that address key market challenges.

Modularity/Vessel Flexibility

We base our solutions on modular equipment and scalable system designs where you choose the layout philosophy based on your business objectives:

- Optimize the lay system to specific operations
- Quickly re-purpose your vessel between contracts
- Change between types of lay operations with minimal modifications to equipment or layout



Lay systems

Our rigid and flexible lay systems range from small modular bolt-on solutions that can be quickly mobilized on any vessel of opportunity, up to large specialized vessels with integrated pipe carousel systems. We are the market leader on large carousel systems and we use our extensive experience to create cost-efficient vessel adaptations that provide the lay system characteristics you need.

Shallow/Deep

We can optimize your lay solutions for either shallow or deep lay operations, or provide you with the flexibility to do both. Our most advanced systems provide flexibility by design. Or choose our scalable system layout which enables you to re-configure your vessel through simple component upgrade or replacement.

Rigid/Flex/Cable

Our equipment is designed to handle a wide range of products. Tensioner pads, rollers, chutes and other product contact points can be replaced to give you the configuration required for job. Our hybrid lay system philosophy gives you the ability to cost-effectively re-purpose your vessel to go after a broader range of lay contracts.



Vertical lay systems

Capacity range: engineered to order

The Vertical Lay System (VLS) for flexible products is a simple and efficient method of deploying and recovering flexible flowlines, umbilicals, and power cables by means of tower-mounted tensioner systems. The product is fed from the vessel deck over an aligner, down through the tensioner(s), and then through the deployment bellmouth located on the work platform doors or the moonpool doors.

Key features

- Single or twin multi-track tensioner options
- Vertical or adjustable inclination options
- Tensioner opens outwards to allow crane handling of end-fitting, UTA etc.
- Modular design to suit vessel of convenience with mob/demob in 24 to 48 hours
- Permanent installations for construction vessels

Horizontal lay systems

Capacity range: engineered to order

Horizontal Lay Systems (HLS) are used for the installation of SURF products and subsea power cables. Systems with dual tensioners can be used for both single and dual product-lay if the system is designed to accommodate this. In the dual-lay mode both products can be bundled together as they exit the tensioners.

Key features

- 2, 3 or 4 track tensioner options
- Tensioner tops open to allow crane handling of end-fitting, UTA etc.
- Dual-lay operations for cable lay with additional fiber optic cable options
- Plain overboarding chute, conveyor track or wheel options
- Installation possible using vessel crane

S-lay & J-lay systems

Work flow and vessel logistics are key components when designing large lay systems. We invest in a holistic approach to understand your operational goals. We design solutions that optimize equipment for your vessel and we carefully consider the human interactions that take place throughout the entire lay process.

Managing the Process

We manage your entire process - from the point where pipe is loaded and stored on the vessel, through the intricacies of transferring pipe safely to welding stations, and finally applying the right tension control when deploying the pipe. Our integrated control systems monitor and manage the entire process and make sure that each step in the production line is synchronized.



J-lay systems

Primary function: lay of rigid products in J-lay systems
Capacity range: engineered to order

J-Lay systems negate the need for an expensive spoolbase required by reel lay systems. The vessel can remain on station continuously laying pipe supplied by supporting vessels. They are most commonly used for deep water pipeline installation. Pipe stalks are aligned and welded to the seagoing pipe in the tower. The pipe leaves the tower in the vertical orientation and forms a J-configuration as it touches down on the seabed. The tension is used to control the bend radius at the seabed, ensuring the pipe stress remains within acceptable limits.

Key features

- Pipe diameters from 6"NB to 48"NB
- High top tension
- Ultra-deep water capabilities
- The tower can operate through 20 - 90°, allowing product to be laid in shallow or deep water
- Suitable for fatigue sensitive pipe (risers)



S-lay systems

Primary function: lay of rigid products in S-lay systems
Capacity range: engineered to order

S-Lay is typically used in the deployment of large diameter, concrete-coated and heavy walled pipes where the minimum bend radius is large. It is commonly used in shallow to medium-depth waters. Deepwater deployment is possible but requires a large stinger and higher tension capacities. Pipe joints are fed through a set of horizontal tensioners and over a stinger into the water. The stinger is a supporting structure mounted at the stern of the vessel that maintains the bend radius of the pipe within allowable limits.

Key features

- Pipe diameters from 6" to 72"
- High top tension
- Deep water capabilities
- Tensioner track suspension to allow passage of anodes
- Large tensioner track opening to allow passage of end terminations etc.
- Suitable for low friction coefficient coated pipes

Lay equipment

We supply a broad range of lay equipment to suit existing vessels or newbuilds. Our suite of equipment is proven on many lay systems currently in operation around the world.

Lay Equipment Supplied

- Horizontal axis reels
- Reel drive systems
- Carousels
- Tensioners
- A&R winches
- Traction winches & take-up reels
- Pipe handling
- Stinger & stinger handling systems
- Stinger rollers
- Deck-deflectors & chutes
- Internal line-up clamps
- Clamps
- PLET systems
- Work platforms
- Supplementary tools

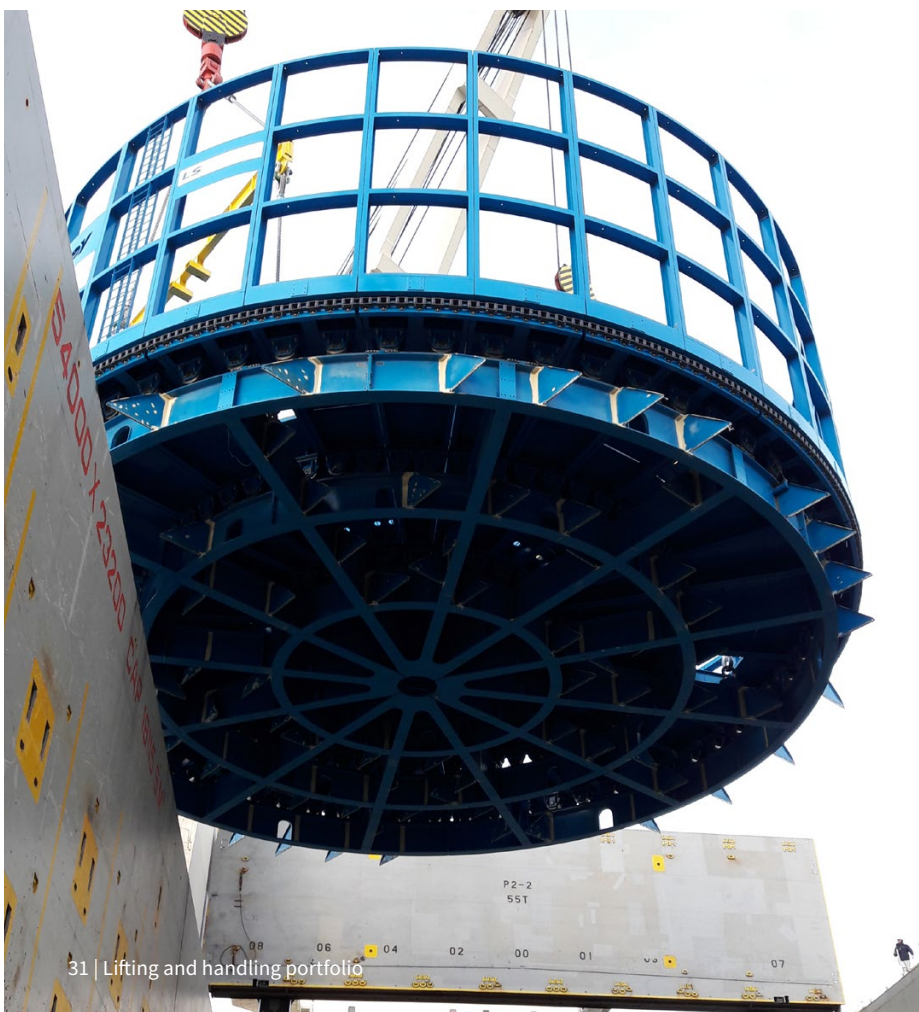

Reel drive systems

Primary function: deployment of flexible pipe reels
Capacity range: engineered to order

Reel Drive Systems (RDS) are designed to deploy and recover umbilicals or flexible pipes that are stored on standard flexible product reels (typically Ø8.6 m up to Ø12.4 m). The RDS hub is specifically designed to suit the market leaders of flexible product reels, including NOV Flexibles. The system can be fully automated and designed to accommodate single reels or multiple reels in series on the deck of the vessel tensioners.

Key features

- Lightweight design decreases deck weight and allows the system to be used on smaller vessels
- Quick mobilization and demobilization – easy to change equipment
- Designed to suit a wide range of reels and capacities
- Capable of skidding with full reel weight
- Integrated reel fastening system
- Multi-reel drive system
- Automated skidding system – can move from one reel to another for spooling on a multi-reel drive system
- High outboard tension options



Reel drive system

Horizontal axis reels

Primary function: storage/spooling of rigid products
Capacity range: 1,500-4,500 t

Horizontal axis reels are designed as the storage unit for rigid and high bend-stiffness flexible pipes where it is required to maintain back tension. Reel lay allows for the continuous, rapid lay of products. Reels can be supplied as part of a complete storage, handling, or lay system, or as a stand-alone modular unit. It is mounted on a common shaft, supported by bearings to the vessel deck. The reel is powered by multiple drives mounted to a gear ring attached to the flange. Pipe can be fed onto the reel via an independent spooling system.

Standard models

- 2,800 t capacity horizontal axis reel

Key features

- Diameter range 15 - 32 m
- High back tension options (up to 190 t)
- Load and unload with ease
- Can be designed for single-point lift fully assembled (excludes product load)
- Easy to access support bearings
- Regenerated power can be burned off or supplied back into the vessel power system to reduce operating costs.

Carousels

Primary function: storage/spooling of flexible, umbilical, and rigid products
Capacity range: 1,000-9,000 t

Carousels are designed as the storage unit during the manufacture, transportation and installation of continuous lengths of low bend-stiffness flexible pipe, tube and hose umbilicals, and power cables. Supplied as part of a complete storage, handling, or lay system, or as a stand-alone modular unit for offshore or onshore use. The carousel rotates around a kingpost bearing and is supported by concentric rings of rollers. An articulating loading arm is used to feed the product. The carousel is powered by multiple drives located around the perimeter and can be mounted below or on deck. A special variant of carousels, called bobbin carousels are used when the bend-stiffness of the product is high and back tensioning must be maintained. A spooling system is also typically used to feed the product.

Standard models

- 2,000 t capacity basket carousel
- 6,000 t capacity basket carousel
- 3,000 t capacity top hat carousel

Key features

- Diameter range 12 -30 m. Larger if required
- Load and unload with ease
- Can be designed for single-point lift fully assembled (excludes product load)
- Modular design
- Resilient mounting technique supports the even distribution of the load
- Easy access to support rollers
- Single slew bearing support option



Integrated horizontal axis reel

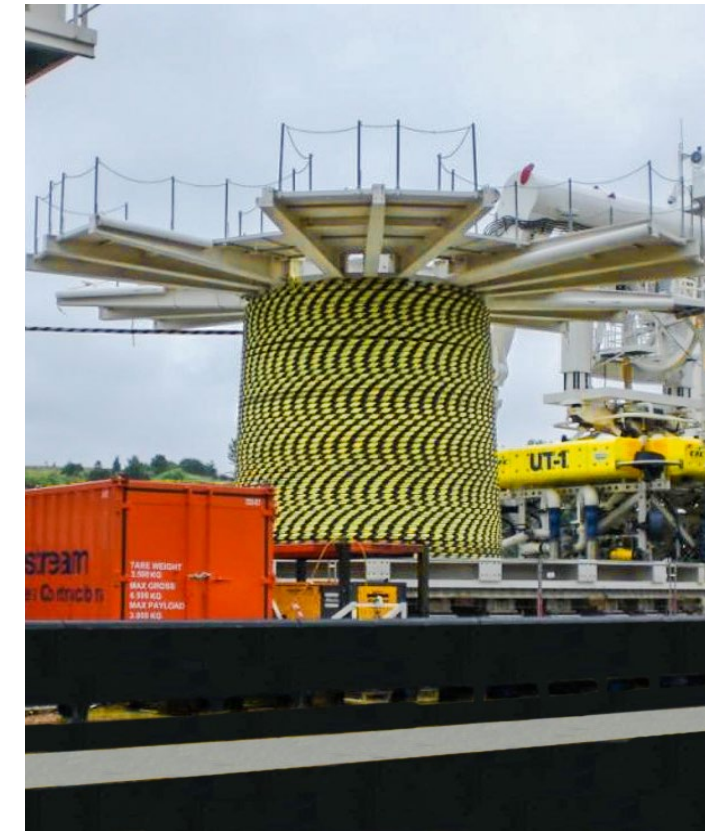

Bobbin carousel



Basket carousel

Tensioners

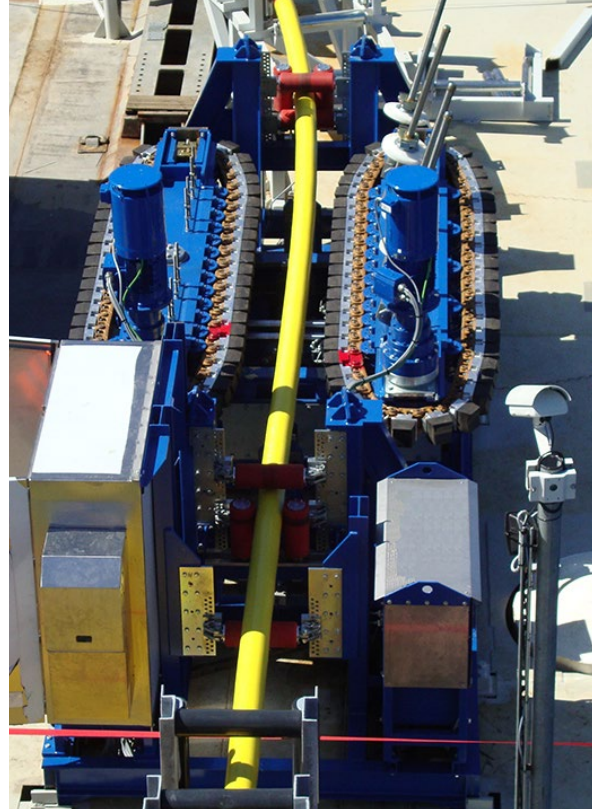

Primary function: offshore lay systems
Capacity range: engineered to order

Tensioners consist of multiple tracks mounted in a support frame. They are designed to handle a wide range of products including rigid pipe, flexible flowlines, umbilicals, composite pipes and power cables. The tensioners can handle different operating conditions and a wide range of friction coefficients. Track drives are electric or hydraulic, with vector drives being the preferred choice for accurate and precise speed control.

Key features

- 2, 3 or 4 track tensioners available
- Product diameters from 50 - 630 mm or customized to meet client requirements
- Outer track hinges open to allow crane handling of end-fitting, UTA
- Large clearance through center of tensioner for passing fittings
- Option of steel or rubber track pads with quick release function to suit different product requirements

10te - top loading horizontal 2 track tensioner

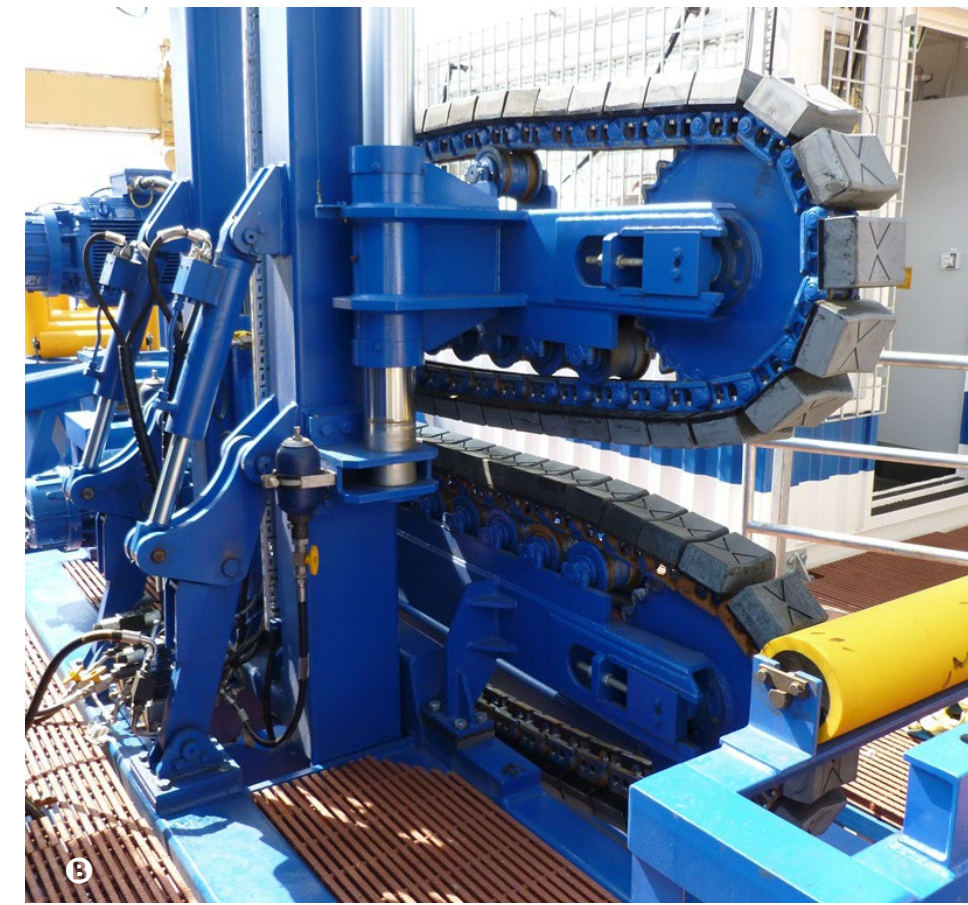

A - 90 te 4 track VLS tensioner B - 15 te side loading horizontal 2 track tensioner C - 70 te (2 x 35) tensioners tandem mounted for a dual lay capability



35te - 4 track multi-orientation tensioner with dual lay capacity



A&R winches



Traction winch

Primary function: Abandonment and recovery of pipelines, flowlines and umbilicals

Our dedicated in-house design and engineering capabilities allows us to supply tailored winch solutions for A&R and deep lowering applications. Winch control systems can be supplied as stand-alone or integrated with the pipe tensioners system and active heave compensation (AHC) equipment. The winches can be equipped with load measurement, length measurement, and slack rope protection.

Products include

- A&R winches (single or double drum)
- Storage winches
- Traction Winches
- Active heave compensated winches
- Umbilical reels
- Spooling winches
- Deepwater lowering winches
- Sheaves (instrumented, folding, flip, beam sheave, deflector)
- Fairleads for ropes
- Fully automated tension transfer with pipe tensioners



A&R single drum winch

Pipe handling systems

Primary function: pipe handling on lay vessel and onshore fabrication of multiple joints

Capacity range: single and multiple joints

Pipehandling systems are design to help you manage simple equipment such as SJ, up the complex QJ pipe fabrication systems for J-Lay. Our pipe handling equipment can be fully automated by “PipeFlow Master” software. Once pipe processing is completed, this software manages pipe transfer to the next working station automatically, without the need for manual input.

Key components

- Integrated handling systems supplied in modules over skids
- Elevators
- Longitudinal conveyor rollers and damping system for collar passage
- Walking beams
- Working stations
- Transfer systems
- Line-up stations for DJ, firing line and QJ
- Main line roller and tracks
- Sterns roller and tracks
- Pipe davits
- Hydraulic power units
- Control and monitoring system
- PIP equipment including pusher, line up, and inserting tools

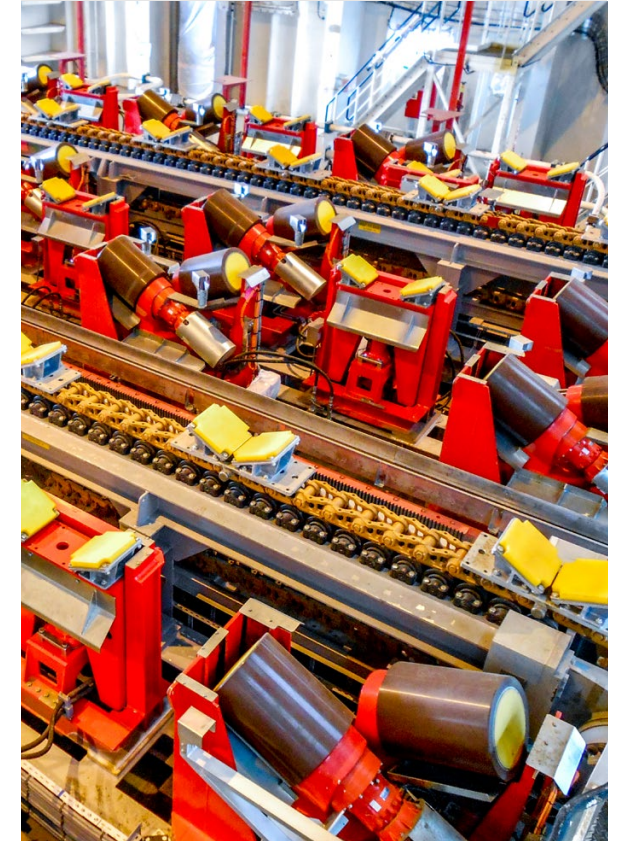

Stinger & stinger handling systems



Primary function: A&R and deep lowering

Our expertise in pipelay and handling systems also translates to the design, manufacture, assembly and testing of stinger and stinger handling systems. Based on your specification, we complete the structure with the accessories you need.

Products include

- Booms stinger handling with jacking system
- A-frame stinger handling with winch and reeving system
- Horizontal rollers (single, triple, quadruple) manual or remotely adjustable
- Vertical rollers manually or remotely adjustable
- Load cells monitoring system
- End roller support (fixed or adjustable)
- Stinger telescopic articulations



Deck-deflectors and chutes

Primary function: lay of flexible products

Capacity range: 25-100 t

Overboarding chutes are used to lay flexible products from reel drive or horizontal lay systems, under relatively low tension. They maintain the product radius as it is fed from the deck into the water. The interface surface of the chute can either be a carbon or stainless steel bearing material or a conveyor track arrangement

- Product diameters from 50 - 630 mm or customized
- Exit flare to maintain product radius
- All contact points are smoothly rounded to protect product from contact damage
- Jacking system to maintain centerline throughout product diameter range (option)



Clamps

Primary function: control and support

Capacity range: 25-2,000 t

We supply friction and collar clamps. Friction clamps use hydraulic cylinders to grip the pipe via a series of interface pads. Collar clamps provide a bearing surface to support a collar fitted to the product. J-Lay systems use traveling and static friction clamps in tandem.

- Retractable to optimize access to product and provide clearance for large terminations
- Easily adapted to suit product diameter range
- Back-up accumulator system ensures friction clamps hold load safely in case of power black-out
- Mounting arrangements to suit client needs
- Large flex lay clamps can be fitted with exit chute option



Internal line-up clamps

NOV supplies a wide range of lay systems tools including:

- Copper shoes
- Wireless remote control
- HI-FORCE expanders (to recover out of roundness without damaging pipe)
- Motorized wheel
- Proximity sensors (to sense pipe end and automatically slow down /stop)
- Winch with load cells for buckle detector
- Parking brake module
- Emergency brake (J-Lay)
- Gas purging system
- Stainless steel kit for Corrosion Resistant Alloy (CRA)
- CAMERA inspection system
- HI-LO Measurement System





Other products

In addition to cranes and pipe lay equipment, we also provide other fit for purpose solutions. Our preferred approach is to combine standard products with customized systems to fit specific applications. This approach allows us to deliver excellent performance and durable products in a cost efficient manner.

7 reel hose loading station on Sleipner A

Umbilical winches

Primary function: special purpose winches
Capacity range: 5-10 t

Our winches are tailor made for each intended application. They are configured with single or multiple drums, and are normally equipped with a spooling device or a custom guide arrangement for special applications. The drive system is either hydraulic or electric with a local control panel on the winch. Remote control can also be provided.

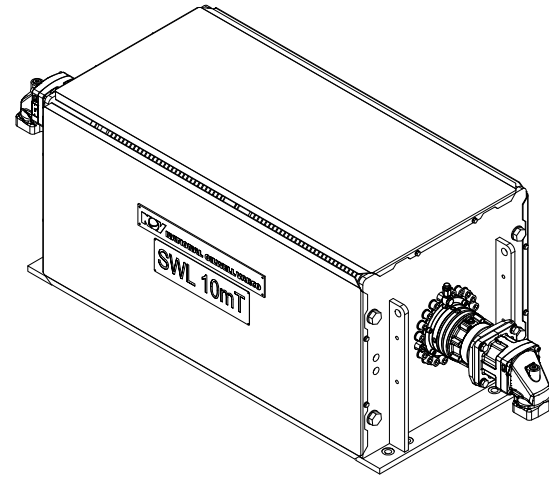

Tugger winches

Primary function: tuggers on cranes or free standing
Capacity range: 3-40 t

We provide free standing tuggers, or crane mounted tuggers typically used to provide control of large loads. Our tuggers can be controlled locally from a remote control or controlled as an integrated part of a larger handling system Both electric and hydraulic designs are available.

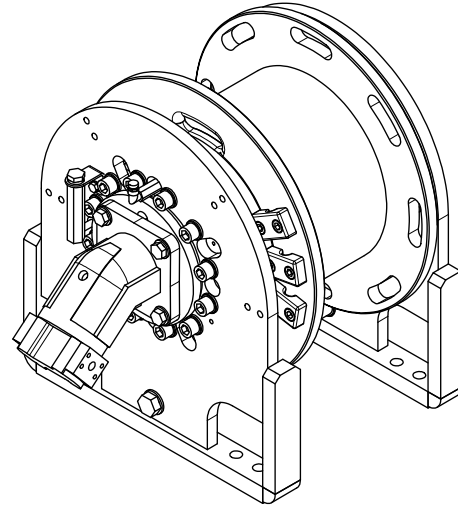

Standard models

- WCT 3 (3 t)
- WCT 5 (5 t)
- WCT 20 (20 t)
- WT 25 (25 t)
- WT 40 (40 t)

Man-rider winches

Primary function: personnel transfer
Capacity range: 110 t

NOV man-rider winches are designed for safe and reliable personnel handling operations on fixed or floating drilling platforms/vessels in offshore working environments. The winches are designed to meet the latest NPD and EU rules for machine directive requirements and is type approved by DNV/ABS.

Standard model

- W-PL-MR

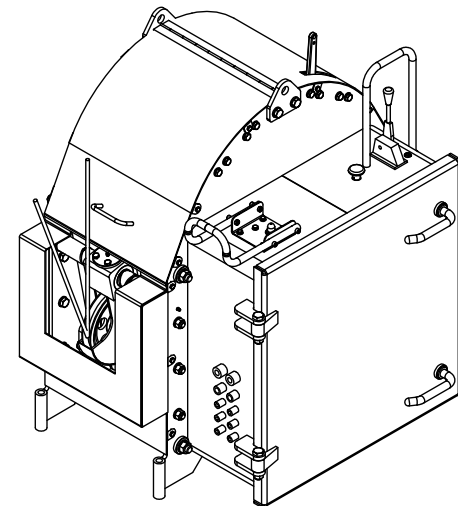

Guide/podline winches

Primary function: guide subsea structures during drilling
Capacity range: 5-20 t

The primary function of guide/podline winches is to maintain constant tension while handling subsea structures. The winches can optimally be used for lifting. For electrically driven winches, the range of maximum constant tension speed is between 1.25 m/s – 3 m/s; maximum lifting speed ranges from 1.25 m/s – 2 m/s; maximum working depth is between 600 m – 2,000 m Hydraulic winches can be delivered for relatively low SWL and max speed.

Standard models

- W-GL-H-05
- W-GL-H-06
- W-GL-H-10
- W-GL-H-12
- W-GL-H-15

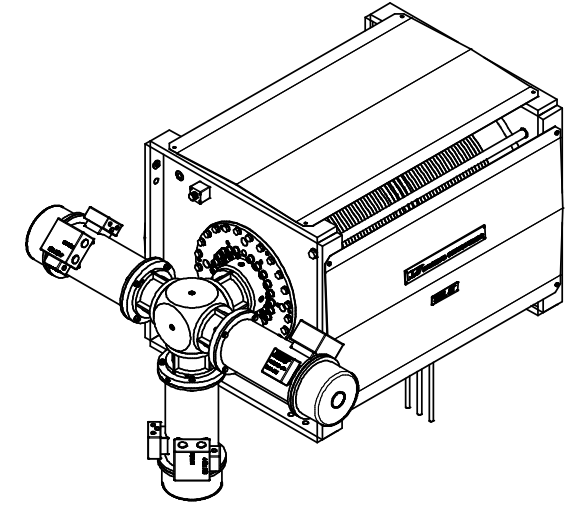

Utility winches

Primary function: for marine environment
Capacity range: 1-30 t

Our utility winches are used for various applications in offshore construction, drilling and production. Speeds and capacities are sized for each installation. The winch is driven by a hydraulic motor integrated into a planetary gearbox located in the winch drum.

Standard models

- W-U-H-01
- W-U-H-03
- W-U-H-05
- W-U-H-10
- W-U-H-15
- W-U-H-20
- W-U-H-30

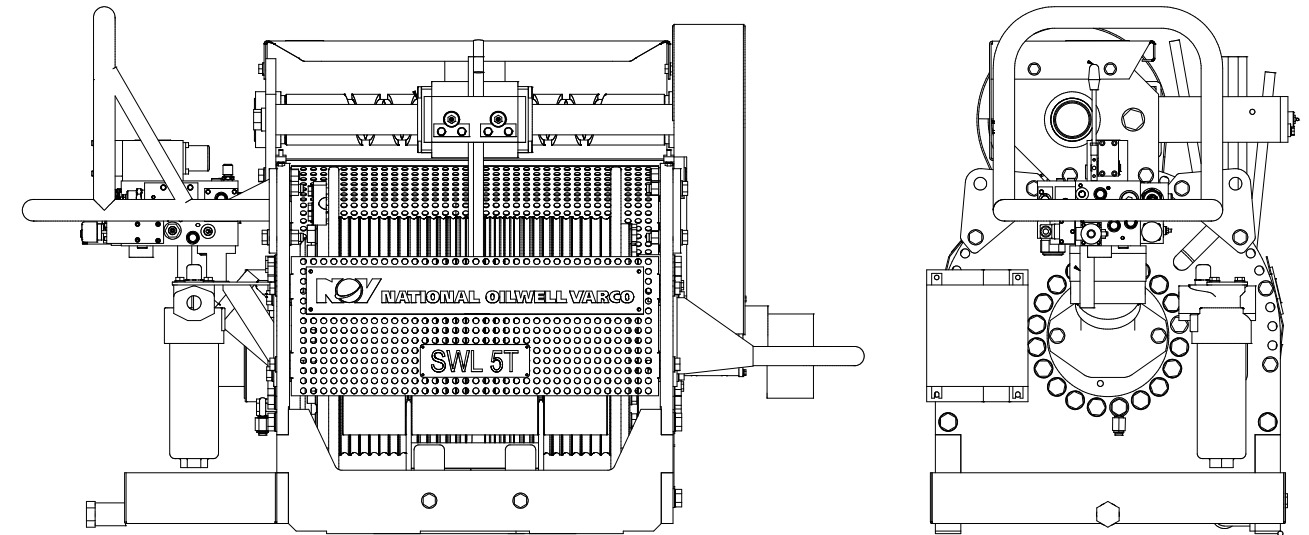

Hose loading stations

Primary function: bunker/loading operation

Capacity range: 1-12 reel/up to 120 m hose

The Hose Loading Station (HLS) is designed for offshore bunkering operations, transporting fluids and dry bulk between supply vessels and fixed or floating production/drilling units. Providing excellent safety for personnel during operation and maintenance. The HLS minimizes the risk of pollutive spillage and extends the lifespan of the loading hoses. Single and multi-reel configurations, powered hydraulically or electrically, are available. The simplicity of the design is suitable for special customer requirements.

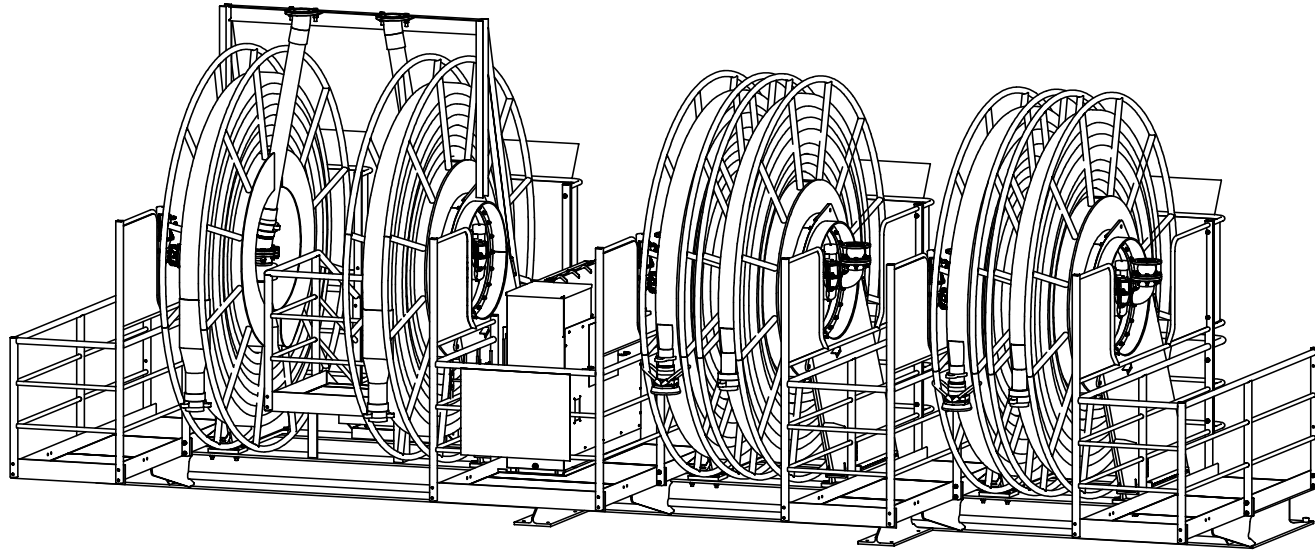

Anchor handling equipment

Primary function: anchor handling

Capacity range: 200-600 t

The Anchor handling packages we provide are recognized for combining extreme power with safe and efficient operation. Our anchor handling systems consist of a complete suite of equipment to support the anchor handling or towing operation - including chain pulling winches, chain replacement tools and handling cranes. The patented "LOADLIM" clutch absorbs dynamic forces and safeguards the vessel in critical situations. Our Anchor Handling and Towing Winches (AHTW) can also be equipped with active heave compensation.

Main Equipment

- Stern Rollers
- Secondary winches (100-200 t)
- (double or single)
- Various handling cranes
- Towing winches (200-600t)
- Chain replacement tools

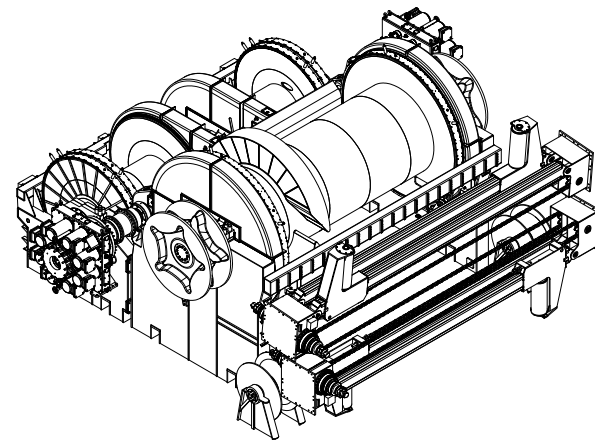

Pull-in systems

Primary function: special purpose winches

Capacity range: 30-800 t

Our comprehensive range of winches and chain jack designs are leveraged to create optimal and cost effective pull-in solutions for FPSOs and platforms. Our pull-in designs cover both linear and rotary steel wire or chain systems, fiber rope systems and combined mooring and pull-in winches. We also provide standard riser and pull-in winches and A&R winches.

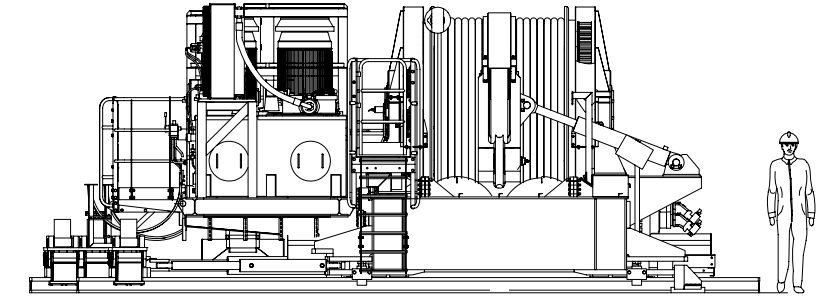
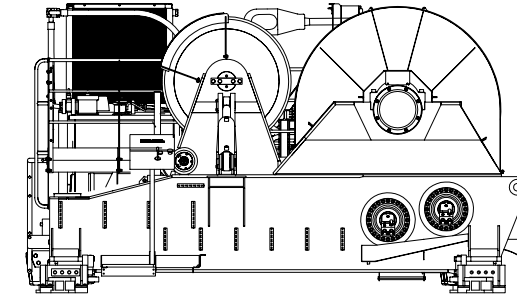

Drill line reels

Primary function: storing drill-line

Capacity range: 2,250-4,500 t

The Drill Line Reels (DLR) are used to store the drill-line. In a typical derrick lifting arrangement the drill line rope is routed from the DLR to the drawworks passing through the deadline anchor, crown block and travelling block to allow hoisting activities at the well center. DLR's are not used for lifting.

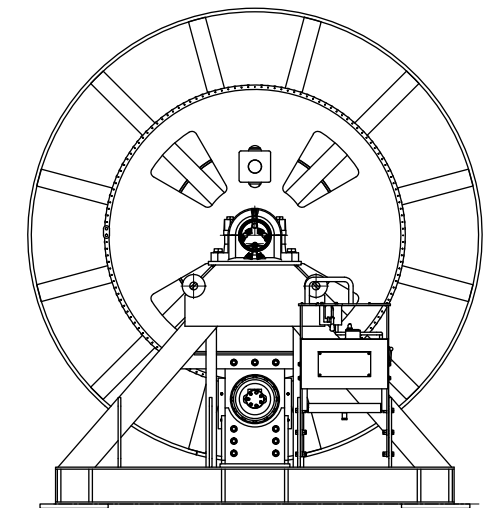
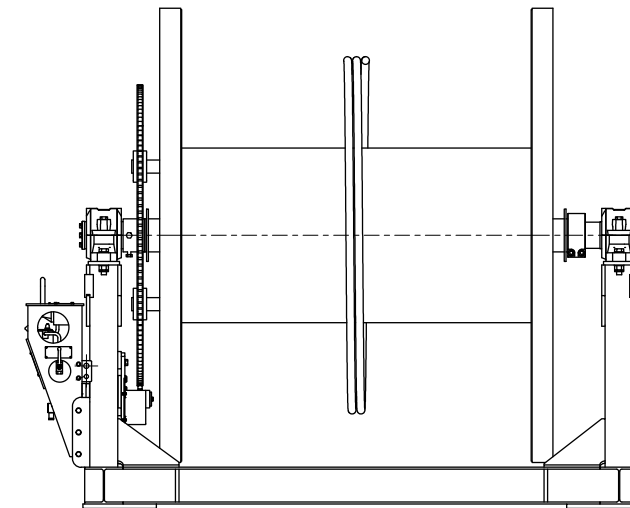

Mooring systems

Primary function: handling mooring vessels

Capacity range: 50-200 t

We design and manufacture complete mooring systems for drilling, production and construction units. Depending on the application, the main components are the fairleads, linear or rotary chain jacks, mooring winches, windlasses, chain stoppers and chain handling systems. We also provide power systems for mooring operations including drives and HPUs.

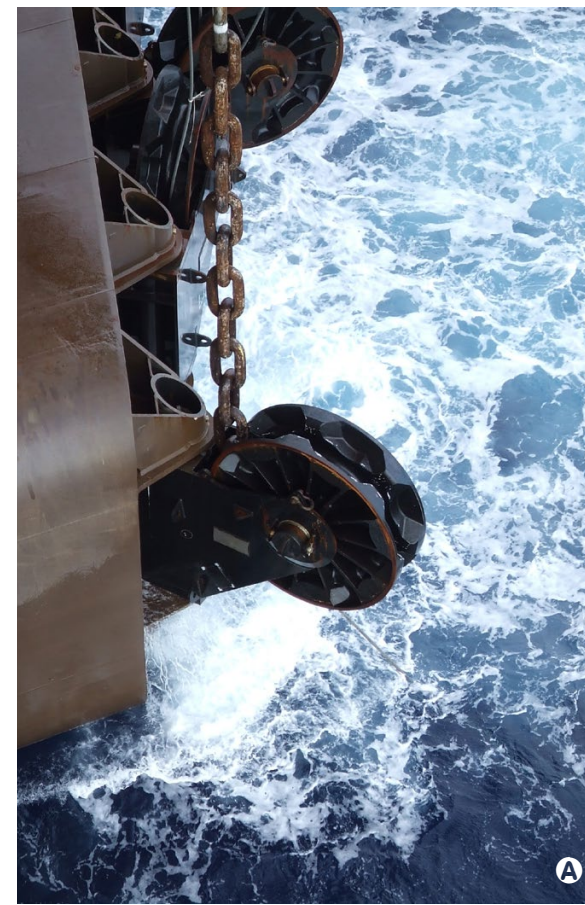
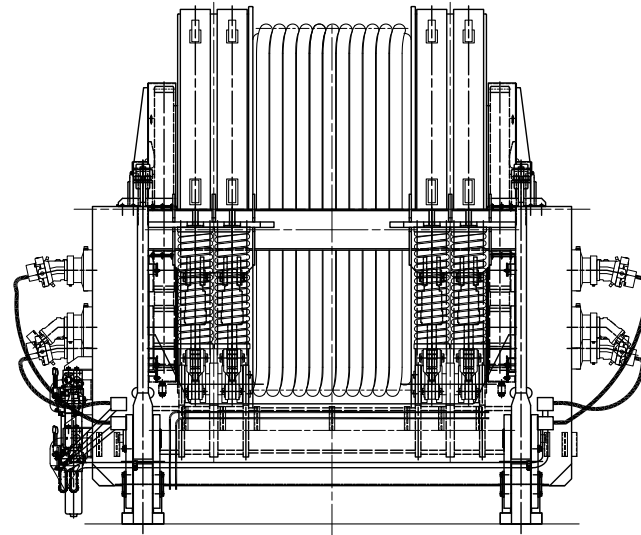
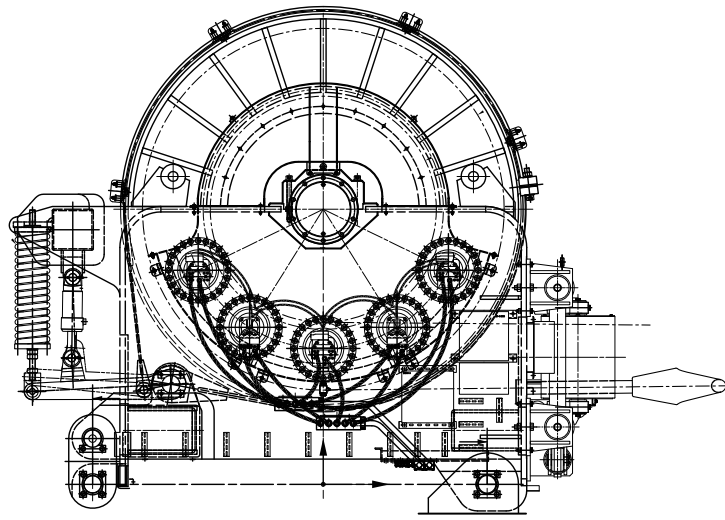

A - Rotary fairlead B - Hose loading station C - Buoy pull-in system

Single layer winches

Primary function: drilling and well intervention

Capacity range: 200-2,000 t

Single layer winches (SLW) are highly suitable for applications where durability, reliability and low maintenance are combined with the need for lifting objects with a relatively short spooling distance. The concept uses 3-8 parallel ropes spooled on individual drum sections connected in a single winch arrangement. The ropes are spooled in one layer on the drum to minimize wire wear. SLW's are used as an alternative to traditional drawworks in drilling.

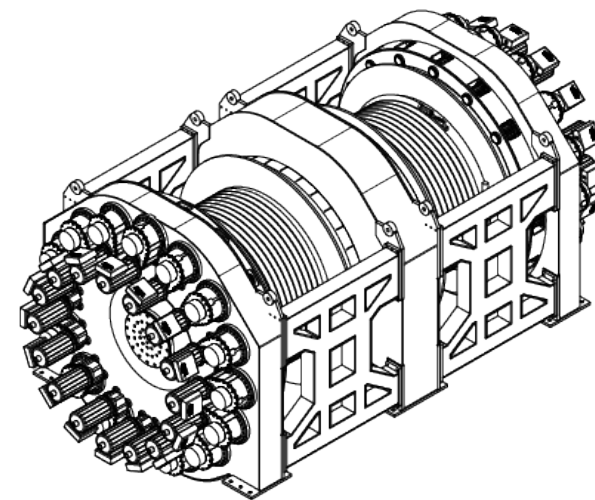

Standard models

- SLW 750
- SLW 1000
- SLW 1250
- SLW 1500
- SLW 1750
- SLW 2000





Aftermarket services

We are your partner for the full lifecycle of your equipment. Our aftermarket team helps you maximize uptime and improve performance in operations around the globe.

Uptime and reliability are key to your success

In addition to 24/7 technical support centers and a global team of field service technicians, we provide aftermarket engineering services, repairs, inspections, surveys, spare parts, and training. As equipment moves into the field, we stand ready to support it with the best customer service in the industry.

Service and repairs

If planned or unplanned repairs are needed, our strategically placed service centers are always ready to support our customers. Our support team consists of both crane specialists and an extensive and global support organization. As an OEM, we hold our rebuilds to the highest recertification and quality assurance standards. Our global parts inventory and a wide range of capital equipment replacement options help minimize issues that could affect your critical path. In addition, equipment exchange programs are available. Through our used equipment refurbishment program, we provide viable, short-turnaround solutions to immediate capital equipment needs complete with data books and certificates of conformance as required.

Technical support

We offer access to a technical support team with multi-skilled backgrounds to troubleshoot and resolve equipment needs 24/7. Our global pool of qualified field service technicians and subject matter experts work together quickly to keep your core operations running. Our teams utilize NOV's web-based application "Tracker" to record, manage, and resolve issues.



NLift training simulator

We provide training environments to accommodate various levels of operator training.

The NLift simulator range goes from small table-simulators that focus on the individual functions of the crane – to dome simulator environments where crane and deck operators can train together on complex lifting scenarios.

Our largest state-of-the-art simulator is equipped with a standard NOV offshore crane cabin. Unlike most crane simulators that use generic user environments, this simulator is configured with crane specific control system software, as delivered to the customer. For crane operators, an environment very close to the real-world experience is provided, which allows for advanced training based on customer defined scenarios. Deck operators have their own separate workstations where they will “work on deck” in front of large screens and communicate with the crane operator by radio. A separate briefing room will be used for planning and reviewing lifting operations.

NLift simulators are normally provided through complete training setups from NOV, but simulators are also sold separately.





Equipment packages

We are able to deliver the most efficient and reliable equipment packages in the marine industry by striking a balance between standardization, highly automated self-contained products, and tailored layouts.



Technology

Technology

Machines from NOV are designed to work together. Our approach of using standard interfaces and a managed layout leads to efficient performance.

Turnkey deliveries

We deliver turnkey systems from several locations in Asia. This is done through our select partner facilities or at our own state-of-the-art facility located in Korea.

Installation and commissioning

Our installation and commissioning team is your single point of contact to organize and manage the large-scale installation schedule at your construction site. We install, commission, and deliver seamless packages to customers and yards worldwide.



Turnkey deliveries



Installation and commissioning

- Significantly reducing the number of interfaces towards the yard and other suppliers. We manage all internal interfaces.
- Organizing and managing large-scale installations on-site. Equipment integration that is on-time, on-budget, with documentation and in compliance of regulations.
- Designing automated systems with machines that are seamlessly integrated and optimized to work with each other for optimal performance – whether you order a standard model or a tailored design.
- Reducing cost and complexity of installations through the removal of duplicated items when combining several machines.



Standardized equipment

With decades of experience in the marine industry, we have standard equipment designs that are field-proven and ready to go to work in the following applications.



Construction

- Offshore cranes
- Subsea cranes
- Heavy lift post cranes
- Heavy lift A-frame cranes
- Around the leg cranes
- A-frames



Pipe/cable lay

- Horizontal lay systems
- Vertical lay systems
- Vertical reel lay systems
- J-lay systems
- S-lay systems
- Basket carousels
- Horizontal axis reels
- Top hat carousel reels
- Reel hub drives
- Tensioners
- Work platforms
- Overboarding chutes
- Clamps
- Pipe handling and fabrication systems
- Subsea cranes



Drilling

- Offshore cranes
- Subsea cranes
- Shipboard cranes
- Pipe handling cranes
- Umbilical winches
- Tugger winches
- Anchor handling systems
- Mooring winches
- Pull-in systems
- One layer winches
- Hose loading stations
- Well intervention system



Production

- Offshore cranes
- Pipe handling cranes
- Umbilical winches
- Tugger winches
- Anchor handling systems
- Mooring winches
- Pull-in systems
- One layer winches
- Hose loading stations

Fully integrated solutions that offer predictability and repeatability from day one.



MSB crane on Norman Maximus



Tailored solutions

Once you have selected the equipment necessary for your daily operations, our engineering team will work with you to tailor the equipment layout to ensure that your work flow is optimized.



One control system

We employ an integrated control system where various equipment can be integrated into one solution that automates equipment response, enabling safe operations without straining your resources.



Your partner
for a lifetime
of lifting.

National Oilwell Varco has produced this brochure for general information only, and it is not intended for design purposes. Although every effort has been made to maintain the accuracy and reliability of its contents, National Oilwell Varco in no way assumes responsibility for liability for any loss, damage or injury resulting from the use of information and data herein. All applications for the material described are at the user's risk and are the user's responsibility.

Rig Technologies Headquarters
10353 Richmond Avenue
Houston, Texas 77042
USA
+ 1 832 424 7300

Rig Technologies Norway
Dvergsnesbakken 25
Korsvikfjorden Industriområde
4639 Kristiansand
Norge
+ 47 38 19 20 00