

Chemineer HT Agitators

Reliable Proven Performance



NOV

Proven Performance

The HT agitator is a premium product featuring a gearbox specifically designed for mixing applications. Available in both bottom and top entering designs, this rugged performer can be tailored to meet virtually any process from critical chemical reactor systems to routine storage applications. Its superior design offers high strength, low wear, quiet operation, and minimum maintenance.

The reliable and rugged HT agitator has provided long, trouble free service in harsh, demanding applications. For open or closed tanks, the HT agitator is the industry standard of reliability and technology in mixing.



Large or small, Chemineer HT agitators can be used in various applications throughout any chemical plant

Drive Features

Internal Shafting

- Oversized, low speed internal shaft with a short bearing span reduces deflection and harmful gear misalignment
- Low speed shafts have extra large cross sections for maximum rigidity

Protective Finish

External surfaces are protected with a catalyzed polyurethane finish suitable for indoor or outdoor installations.

Quiet Performance

The high quality of the gears and other internal components, and precise machining of the drive housing contribute to quiet performance well below maximum recommended noise levels of 85 dBA.

Positive Lubrication

- Splash lubrication continuously protects gearing and high speed bearings
- A dry well low speed shaft seal prevents oil leakage
- Lubrication options for high temperature service or low speed applications include an external oil pump and an oil cooling system
- Oil heaters are available for extremely low temperature environments

Extra Capacity Tapered Roller Bearings

- The tapered roller design handles both the radial and axial loads common to agitator drive service
- Standard tapered roller bearing service rating of over 100,000 hours L-10 life throughout the drive
- For simplified maintenance and prevention of housing wear, low speed bearings are carrier mounted and can be replaced without special tools

Drive Internals

The first reduction helical change gears are spline or taper hub mounted for easy removal and replacement. Removing the change gear cover provides direct access to the change gears

without the need to disturb other internal parts or the motor. Second reduction spiral bevel gearing offers low wear for long service, and provides superior efficiency for right angle power transmission.

- Magnetic drain plug is included as standard
- Hardened helical gears precision hobbled and shaved to exact tolerances for proper contact and wear
- Spiral bevel gearing is precision generated, matched, lapped, and individually marked for accurate fit and alignment
- Easily accessible grease fittings lubricate low speed shaft bearings
- The chemical duty paint finish protects against water, acid, or caustic environments, and is extremely resistant to wear and abrasion
- Rugged, fabricated gear drive housing
- Dry well seal prevents process fluid contamination
- All shafts are precision turned on lathes for dimensional consistency and straightness

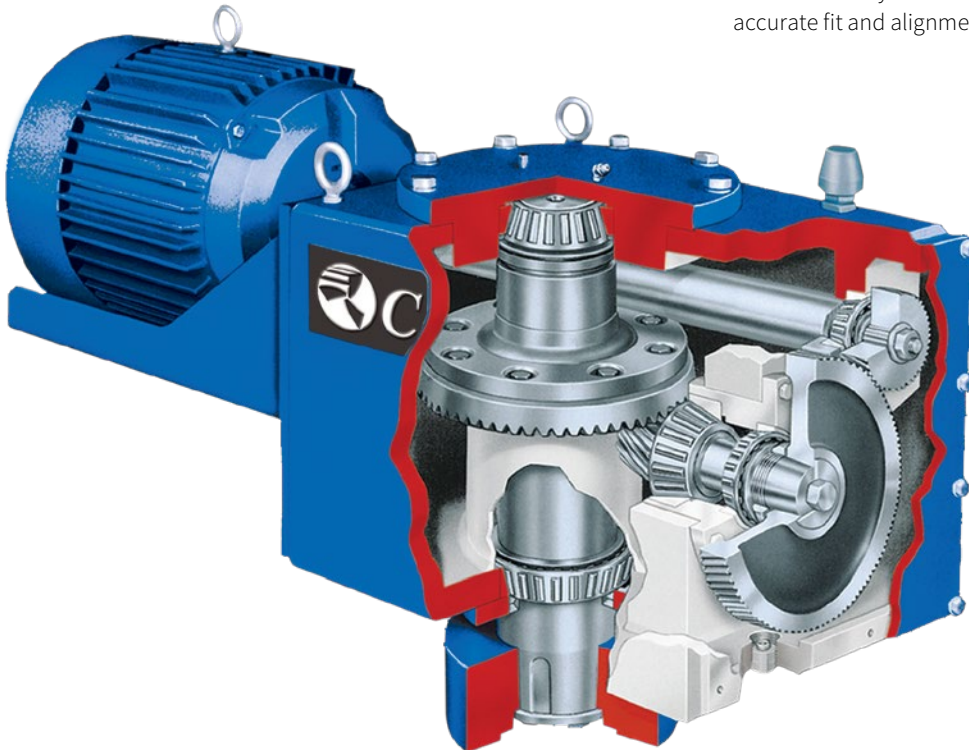

Additional Features

- Standard foot mounted motor
- Compact, high efficiency, right angle double reduction drive

All internal drive components are specific to the HT drive and meet Chemineer's exceptional quality standards

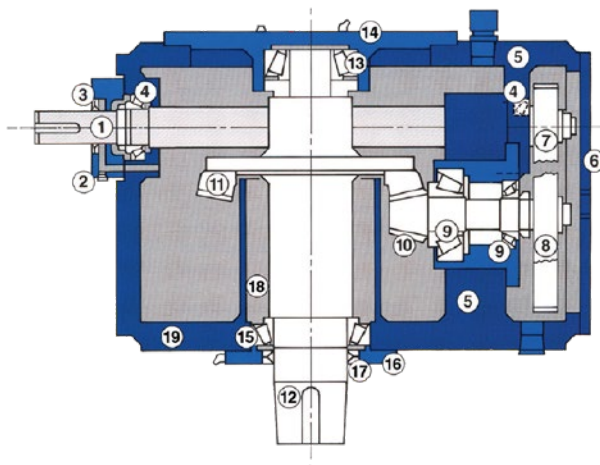

Gearbox Components

- | | |
|---|--|
| <ul style="list-style-type: none"> 1 High speed shaft 2 High speed bearing cap 3 Lip seal 4 High speed shaft bearings (2) 5 Bearing support blocks (2) 6 Change gear cover 7 Change pinion 8 Change gear 9 Bevel pinion shaft bearings (2) 10 Spiral bevel pinion | <ul style="list-style-type: none"> 11 Spiral bevel gear 12 Low speed shaft 13 Upper low speed bearing 14 Bearing cap 15 Lower low speed bearing 16 Lower low speed bearing cap 17 Lip seal 18 Dry well 19 Housing |
|---|--|

Shaft Seals

Seal Mounting

Shaft seals attach directly to the integral ANSI mounting flange on pedestal mounted agitators. All shaft seals are also available as auxiliary units with beam mounted gearbox.

Shut Off Systems

Optional shaft shut off systems allow seal change without the leakage of process fluid or pressure loss.

Types of Seals

A wide selection of shaft seals are available for closed tank processes.



- **Lip Seal**

The spring loaded elastomeric lip seal protects process fluid from dust or atmospheric contamination in low pressure, lower temperature applications.

- **Stuffing Box**

A six-ring stuffing box incorporates a lantern ring and grease fitting to maintain lubrication. A three-ring design is available for low pressure applications.

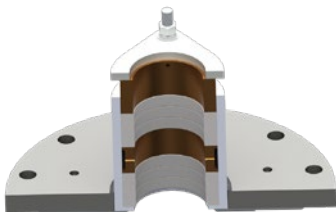

Stuffing Box

- **Mechanical Seals**

Mechanical seals are offered in a variety of materials to design specifically for your process. The seals are supplied from well known seal manufacturers. Special seals are available for high pressure and/or temperature applications.

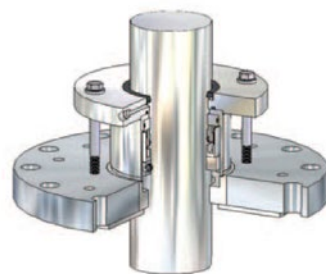

Single Mechanical Seal

- **Single Mechanical Seal**

The single dry running mechanical seal is a suitable choice for applications where a pressurized barrier between the tank contents and the outside environment is not necessary.

- **Split Mechanical Seal**

Split mechanical seals feature a two piece design that simplifies installation and maintenance.

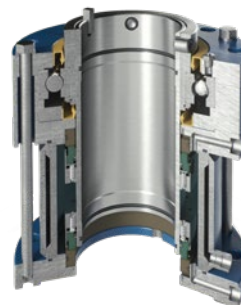

Double Cartridge Seal

- **Double Mechanical Cartridge Seal**

Double mechanical seals can offer the most complete protection against leakage of hazardous or flammable fluids, as well as long life and minimum maintenance.

The cartridge construction greatly simplifies seal removal and installation. The seal cartridge removes as a unit, without disturbing the agitator drive. The cartridge unit can be rebuilt and statically or dynamically bench tested prior to installation. Our standard cartridge includes an integral bearing in the cartridge to reduce shaft deflection and increase seal life.



Step 1



Step 2



Step 3

Seal Change Procedure

The double mechanical seal cartridge is removed in four simple steps requiring no special tools or blocking:

1. Unbolt the spacer spool between the reducer output and agitator extension shaft. The extension shaft drops less than 0.5" into a catcher bracket in the mounting flange to support the shaft and impeller weight.
2. Remove spacer spool.
3. Remove tapered shaft coupling half located above the seal cartridge.
4. Unbolt and slide the entire seal assembly off the extension shaft.

Benefits

- The gearbox does not need to be removed or disturbed during a seal change
- The seal arrangement allows for a seal to be changed faster and more consistently than any other system, regardless of agitator size or age
- A Jacks-n-Rails system is available to simplify removal and installation of large cartridge seals
- Seal shut off available
- Shaft will not disengage from steady bearing
- Drop collar supports wetted parts to leave in the vessel during seal change out



Model 6HTN-20 with double mechanical cartridge seal pedestal mounted to a closed tank

Mounting Options

Adaptable to Any Tank

HT agitators are adaptable to any vertical mounting configuration on open or nozzle mounted closed tanks.

On Open Tanks

Steel plate feet or mounting plates are included on the gear drive to mount the agitator to beams or other supporting structures.

On Closed Tanks

HT agitators can be supplied with a fabricated steel support pedestal to mount the agitator directly to the vessel nozzle.

- The pedestal design includes a standard ANSI 150 lb flange
- High pressure and custom flanges are available

Bottom entry applications can be flange mounted, or independently mounted with a separate seal assembly.



Top entering HTN agitator with pedestal mounted arrangement



Bottom entering HBN agitator with a double mechanical seal and independently mounted drive

Shaft Design

Both process and mechanical considerations determine shaft design. Shafts are sized to resist torsional loads and bending moments induced by hydraulic forces acting on the impeller, as well as to avoid excessive vibration due to coincidence of critical frequencies and operating speed.

Shafting is straightened to tight tolerances—less than 0.003 inches total run out per foot of shaft length (0.25 mm per meter)—for long seal life and smooth operation. Custom couplings, impellers, shafting, and steady bearings are available upon request, including sanitary designs.

Types

Shafting is supplied in a single piece design or in rigidly coupled sections for easy installation. For large diameter shafts, pipe shafting is a viable option with couplings and impeller hubs welded to the shafting.

Couplings

To facilitate assembly in the field, extension shafts are attached to the drive shaft with flanged rigid couplings, therefore shafts do not need to be installed through the gearbox. The couplings can either be removable tapered bore coupling halves or welded coupling halves. In tank couplings simplify installation of long shafts.

Steady Bearings

Steady bearings are available to help support extremely long shafts. Cup tripod, bracket, and pad type steady bearings are standard design options.

Extended Keyways

Extended keyways for adjusting impeller location offer process and design flexibility.

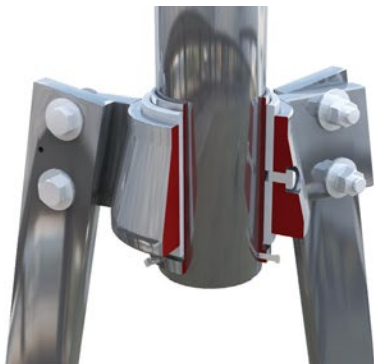

Cup Tripod Steady Bearing



Bracket Steady Bearing

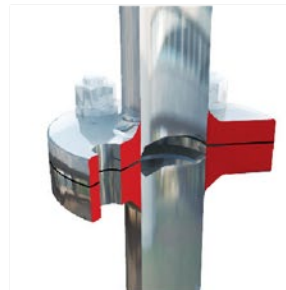

Welded Coupling



Removable Coupling

Dimensions

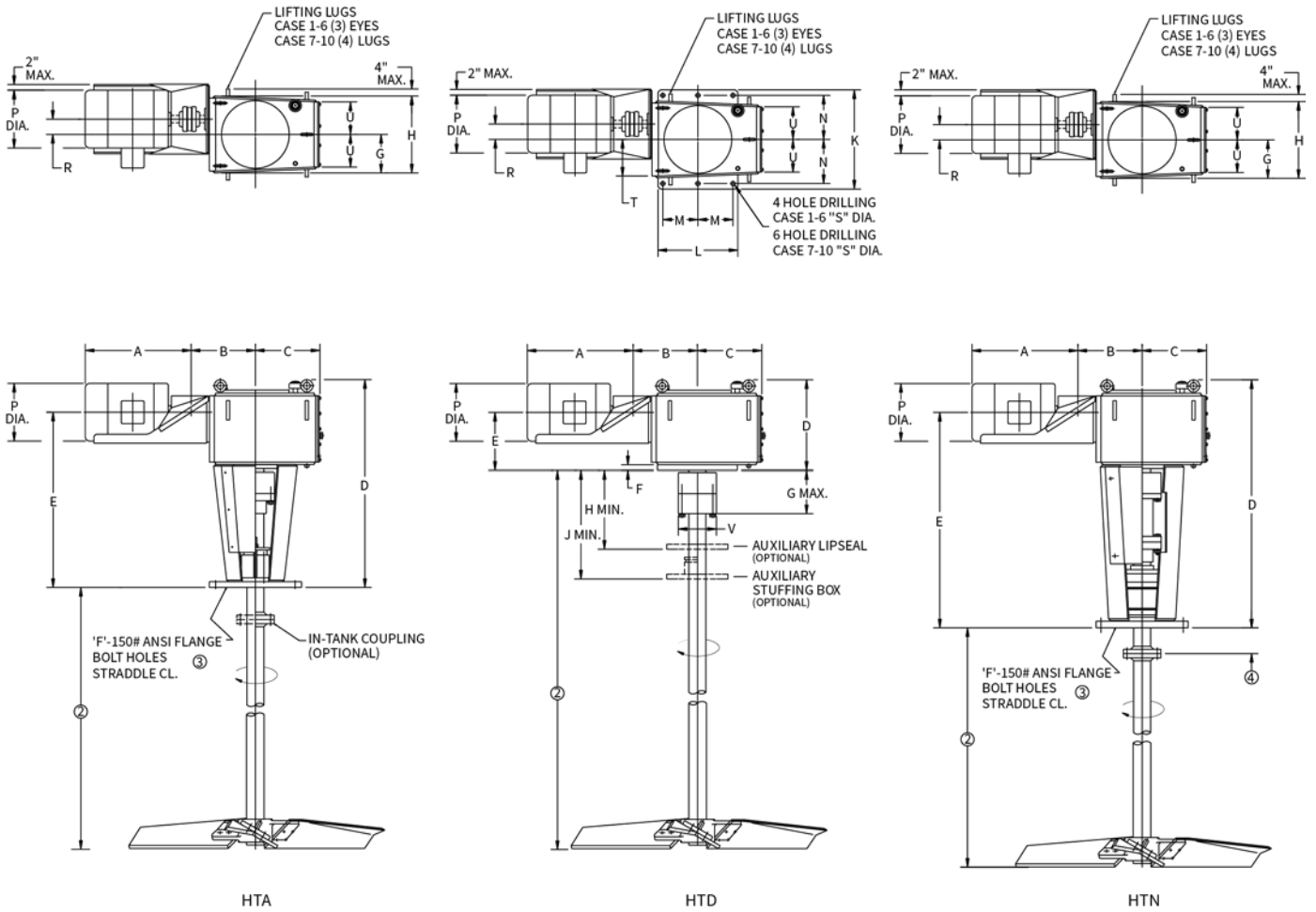

Agitator Dimensions

Case Size	1					2					3					4					5				
Model	HTA	HTD	HTN	HTNS, HTAL, & HTL	HTP	HTA	HTD	HTN	HTNS, HTAL, & HTL	HTP	HTA	HTD	HTN	HTNS, HTAL, & HTL	HTP	HTA	HTD	HTN	HTNS, HTAL, & HTL	HTP	HTA	HTD	HTN	HTNS, HTAL, & HTL	HTP
B	7.5" for all models					9" for all models					10.5" for all models					14" for all models					15" for all models				
C	9" for all models					10" for all models					11.5" for all models					13.5" for all models					15.5" for all models				
D	31.5"	13"	40"	25.5"	25.5"	35"	15"	43.5"	29.5"	29.5"	39.5"	16.5"	47.5"	32.5"	32.5"	43"	19"	51.5"	37.5"	37.5"	46.5"	20.5"	55.5"	40.5"	40.5"
E	26"	7.5"	35"	20.5"	20.5"	29"	9"	38"	23.5"	23.5"	33"	10.5"	41.5"	26.5"	26.5"	37"	12"	45"	31.5"	31.5"	39.5"	13.5"	48"	33.5"	33.5"
F	8"	0.75"	10"	8"	1"	8"	1"	10"	8"	1"	8"	1"	10"	8"	1"	12"	1.125"	12"	12"	1.25"	12"	1.125"	12"	12"	1.25"
G	5"	6"	5"	5"	—	6.5"	7"	6.5"	6.5"	—	7"	8.5"	7"	7"	—	8"	10"	8"	8"	—	9.5"	11"	9.5"	9.5"	—
H	10"	10"	10"	10"	—	12.5"	11"	12.5"	12.5"	—	14"	12"	14"	14"	—	16"	13"	16"	16"	—	18.5"	14"	18.5"	18.5"	—
J	—	17"	—	—	—	—	18.5"	—	—	—	—	21.5"	—	—	—	—	23"	—	—	—	—	25"	—	—	—
R	2" for all models					2.5" for all models					3" for all models					3.5" for all models					4" for all models				
T	—	5"	—	—	—	—	6.5"	—	—	—	—	7"	—	—	—	—	8"	—	—	—	—	9.5"	—	—	—
U	4.5" for all models					6" for all models					6.5" for all models					7.5" for all models					8.5" for all models				
V	—	5.5"	—	—	—	—	6.5"	—	—	—	—	7.5"	—	—	—	—	8"	—	—	—	—	9"	—	—	—

Dimensions

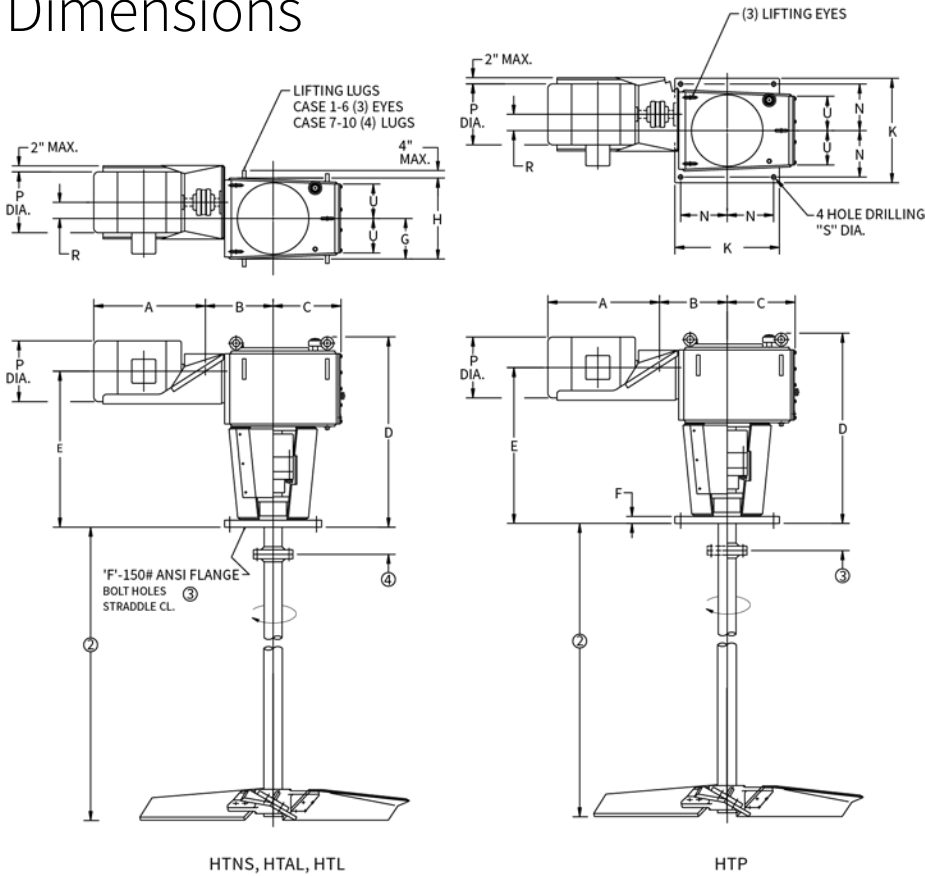

Mounting Dimensions

Case Size	1HTD	1HTP	2HTD	2HTP	3HTD	3HTP	4HTD	4HTP	5HTD	5HTP	6HTD	6HTP	7HTD	8HTD	9HTD	10HTD
K	13"	16.5"	16"	16.5"	18"	16.5"	20.5"	25"	22.5"	25"	25"	16"	34"	38.5"	41"	45"
L	8"	—	10"	—	11.5"	—	16.5"	—	16.5"	—	18.5"	—	21"	22"	26"	33"
M	3.25"	—	4.25"	—	4.75"	—	7.25"	—	7.25"	—	8.25"	—	9.25"	9.5"	11.5"	15"
N	5.625"	7.25"	7"	7.25"	8"	7.25"	9.125"	11.25"	10"	11.25"	11.25"	18"	15.75"	17.75"	19"	21"
S	0.625"	0.75"	0.625"	0.75"	0.75"	0.75"	0.875"	0.875"	0.875"	0.875"	0.875"	0.875"	1"	1.125"	1.125"	1.125"

Agitator Dimensions

Case Size	6				7				8			9			10			
Model	HTA	HTD	HTN	HTNS, HTAL, & HTL	HTP	HTA	HTD	HTN	HTNS, HTAL, & HTL	HTA	HTD	HTN	HTA	HTD	HTN	HTA	HTD	HTN
B	16" for all models				18.5" for all models				21.5" for all models			23.5" for all models			26.5" for all models			
C	18" for all models				22.5" for all models				25" for all models			28.5" for all models			36" for all models			
D	48.5"	21.5"	58.5"	42.5"	42.5"	56.5"	28"	67.5"	50.5"	59"	30"	72"	68"	32"	78.5"	74"	37"	88.5"
E	41"	14"	51"	35"	35"	45.5"	17.5"	57.5"	40.5"	48.5"	19.5"	61.5"	52.5"	22"	68"	61"	24"	75.5"
F	12"	1.25"	12"	12"	1.25"	16"	1.5"	16"	16"	16"	1.75"	16"	20"	1.75"	20"	24"	1.75"	24"
G	10.5"	11"	10.5"	10.5"	—	12.5" for all models			—	14.5"	13.5"	14.5"	16.5"	14.5"	16.5"	18.5"	17.5"	18.5"
H	20.5"	15"	20.5"	20.5"	—	24.5"	16"	24.5"	24.5"	29"	17"	29"	32.5"	18"	32.5"	37"	21"	37"
J	—	25.5"	—	—	—	—	27"	—	—	—	28"	—	—	29.5"	—	—	35.5"	—
R	4" for all models				5" for all models				5.5" for all models			6.5" for all models			7.5" for all models			
T	—	10.5"	—	—	—	—	12.5"	—	—	—	14.5"	—	—	16.5"	—	—	18.5"	—
U	8.5" for all models				11" for all models				13" for all models			14.5" for all models			16.5" for all models			
V	—	9.5"	—	—	—	—	10"	—	—	—	11"	—	—	12"	—	—	13.5"	—

Motor Dimensions

HP	HP		Frame	A ^①	p ^①
	1150 rpm	1750 rpm			
1	—	—	145T	13"	7.75"
1.5	3	—	182T	14.375"	9.25"
2	5	—	184T	15.375"	
3	7.5	—	213T	18"	11"
5	10	—	215T	19.5"	
7.5	15	—	254T	22.875"	12.75"
10	20	—	256T	24.625"	
15	25	—	284T	26.625"	14.5"
20	30	—	286T	28.125"	
25	40	—	324T	29.625"	16.875"
30	50	—	326T	31.125"	
40	60	—	364TS	30.75"	18.5"
50	75	—	365TS	31.75"	
75	100	—	405TS	35"	20.875"
100	125	—	444TS	38.5"	23.875"
125	150	—	445TS	40.5"	
150	200	—	447TS	47.5"	25"
200	250	—			
250	300	—	449TS	51.5"	29"

- Dimensions are for totally enclosed and explosion proof motors.
- Agitator output speed, shaft diameter and extension, impeller design and other optional features to suit application.
- Larger and smaller flanges available, however in most cases, the smaller than standard flange dictates on centerline bolt holes and studs.
- Varies per case and shaft diameter selection. Refer to certified assembly drawing for actual dimension.

Impeller Technology

Chemineer's impeller technology is effectively applied across your spectrum of applications ensuring successful, repeatable results from lab scale to full scale operations. Chemineer's mixing expertise includes high flow, low shear liquid-liquid/solids blending, gas dispersion, high shear blending and viscous mixing. Whether it is R&D or production phase, we have the expertise to solve your mixing challenges.

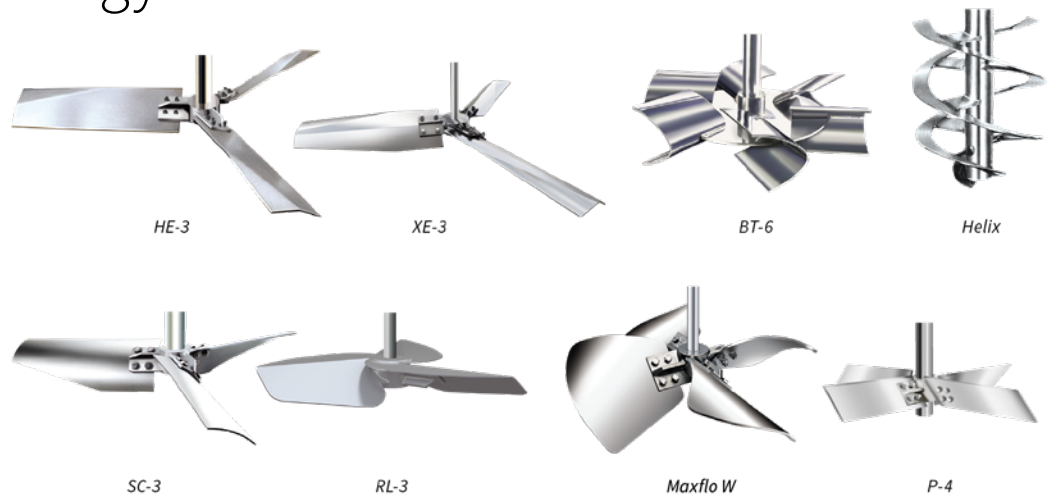

Authorized Service Centers

Our mission is to offer customers immediate assistance to help achieve operating performance goals for agitation and mixing processes. This is accomplished in two ways: ensuring replacement parts and services are available on a timely basis to increase the "uptime" of your systems, and ensuring customers are offered the latest technology to improve the performance of agitation and mixing systems.

We are always ready to help in any capacity you may need:

- Drop in replacement parts of standard and custom Chemineer agitator components
- Emergency parts are shipped from stock in 24-48 hours
- Service centers for analysis and repairs
- Highly training field service technicians to assist with any of the following
 - Full installation services
 - Troubleshooting
 - Start-up assistance
 - Reliability audits
 - Training

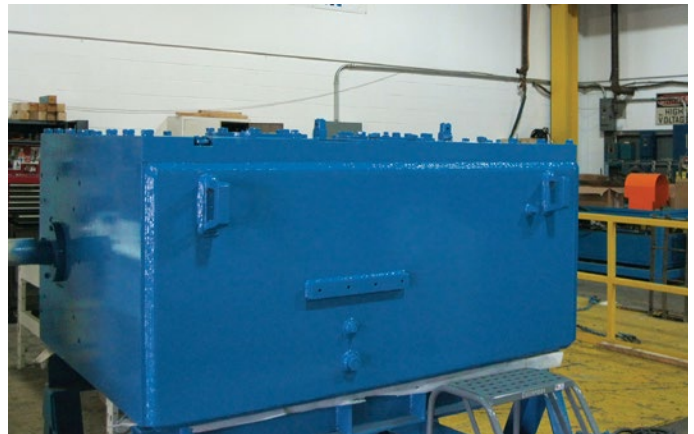

Refurbished Mixer Gearbox Program

Refurbished HT gearboxes are stocked for an economical, quick replacement for units in disrepair. All refurbished gearboxes meet the same high quality standards as new Chemineer gearboxes. Additional features of the refurbished mixer gearbox program include:

- Delivery on HT gearboxes in 24 to 48 hours
- High quality refurbishments built in house to NOV and AGMA standards
- A credit toward the purchase of any refurbished gearbox upon returning your old gearbox
- Accepting worn out gearboxes from any original mixer manufacturer
- One year warranty against material defects and workmanship

Sales Facilities

US Ohio

+1 937 454 3200
chemineer@nov.com

United Kingdom

+44 1332 363 175
chemineeruk@nov.com

China

+86 21 6124 0001
chemineercn@nov.com

Singapore

+65 6271 1121
chemineeruk@nov.com

Mexico

+52 55 3300 5370
chemineerventasmx@nov.com

Austria

+43 1 8923481
chemineeruk@nov.com

Manufacturing Facilities

US

+1 937 454 3200
chemineer@nov.com

United Kingdom

+44 1332 363 175
chemineeruk@nov.com

China

+86 21 6124 0001
chemineercn@nov.com

Corporate Headquarters

10353 Richmond Avenue
Houston, Texas 77042
USA

NOV has produced this brochure for general information only, and it is not intended for design purposes. Although every effort has been made to maintain the accuracy and reliability of its contents, NOV in no way assumes responsibility for liability for any loss, damage or injury resulting from the use of information and data herein. All applications for the material described are at the user's risk and are the user's responsibility.

© 2024 NOV. All rights reserved.
JIG 240877-EE-FMS



industrial@nov.com

nov.com/fms