



# EZstrip™ Transfer Pump

The patented split coupling provides a quick and easy way to disassemble and maintain a progressing cavity pump in place.

## Typical Applications

- Domestic and industrial effluent
- Hydrated lime slurry
- Sludge
- Shear sensitive latex emulsion
- Milk curds, sauces, fruit juices
- Industrial chemicals and detergents
- Starch slurries
- Coating clays, gypsum and silicate
- Paper stocks
- Agricultural slurries
- Saltwater Disposal Truck Offloading

## Capacity

- Up to 225 m<sup>3</sup>/hr (991 US gpm)

## Pressure

- Up to 12 bar (174 psi)

## Temperature

- -10° C to 100° C (14°F up to 212°F)

## Features and Benefits

### Maintain-in-Place

Quickly and safely remove the full drive train including rotor, stator, shaft, rod, and seal in minutes without physical electrical disconnection.

EZstrip Access covers– provide 360° access to coupling rod and drive shaft for easy inspection.

The smooth profile Positive Torque Split Coupling Rod alleviates potential ragging issues, and reduces maintenance and assembly times.

Tie-bar-free design. EZstator clamps lock the stator securely into place. This further reduces stator removal time by over 50% and improves the safety of common maintenance operations.

Captive support foot. The fixed support foot and stator clamp assembly further aids rotor and stator removal.

### Materials of Construction

Available in cast iron or stainless steel with a choice of rotor and stator materials to suit individual applications.

### No Special Tools Required

Pump requires only a wrench and an allen key to maintain.

### No De-Rating Required

Operational parameters unaffected since design has no effect on flow and pressure.

### Eliminate Dismantling Lengths

Suction and discharge ports remain connected to the pipe work. Easily upgrade from any model PC pump, or retrofit an existing EZstrip™ pump model.

### Interchangeability

Compatible with new pumps or retrofitted into existing Compact C and B-Range installations.

### Drive Train Assembly

Pre-assembled drive trains available to support faster reassembly times.



# EZstrip™ Transfer Pump

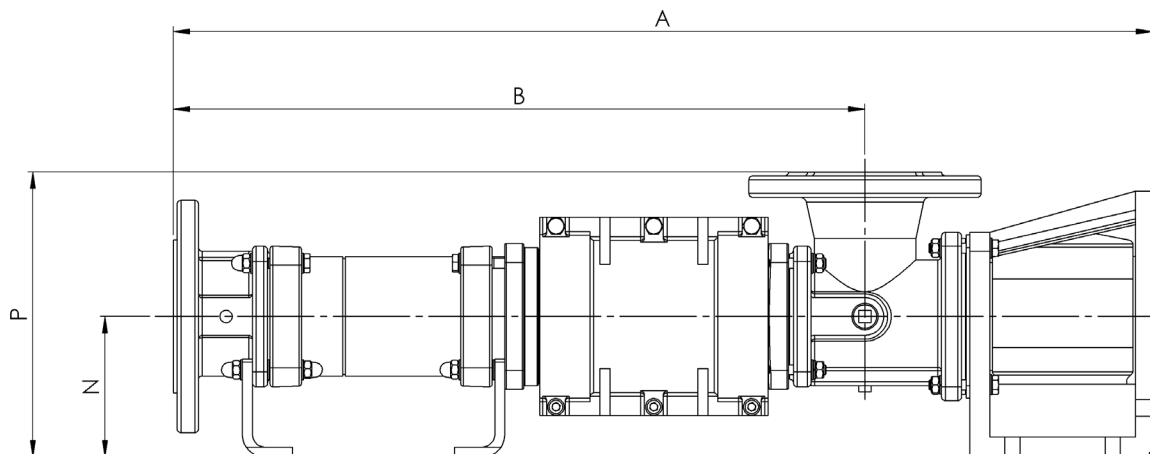

## Dimensions

Model	A	B	N	P
Z34A	781 (30.8)	551 (21.7)	112 (4.4)	227 (8.9)
Z34K	986 (38.8)	756 (29.8)	112 (4.4)	227 (8.9)
Z34B	986 (38.8)	756 (29.8)	112 (4.4)	227 (8.9)
Z35A	842 (33.2)	622 (24.5)	112 (4.4)	232 (9.1)
Z35K	1102 (43.4)	882 (34.7)	112 (4.4)	232 (9.1)
Z35B	1159 (45.6)	882 (34.7)	125 (4.9)	245 (9.7)
Z36A	960 (37.8)	724 (28.5)	125 (4.9)	255 (10)
Z36K	1272 (50.1)	1036 (40.8)	125 (4.9)	255 (10)
Z36B	1355 (53.4)	1036 (40.8)	150 (5.9)	280 (11)
Z37A	111 (4.4)	830 (32.7)	150 (5.9)	310 (12.2)
Z37K	1478 (58.2)	1198 (47.2)	150 (5.9)	310 (12.2)
Z37B	1478 (58.2)	1198 (47.2)	150 (5.9)	310 (12.2)
Z38A	1246 (49.1)	966 (38)	150 (5.9)	310 (12.2)
Z38K	1654 (65.1)	1374 (54.1)	150 (5.9)	310 (12.2)
Z38B	1742 (68.6)	1374 (54.1)	160 (6.3)	320 (12.6)
Z39A	1394 (54.9)	1079 (42.5)	160 (6.3)	345 (13.6)
Z39K	1856 (73.1)	1541 (60.7)	160 (6.3)	345 (13.6)
Z39B	1856 (73.1)	1541 (60.7)	160 (6.3)	345 (13.6)
Z3AA	1476 (58.1)	1161 (45.7)	160 (6.3)	345 (13.6)
Z3AK	2007 (79)	1692 (66.6)	160 (6.3)	345 (13.6)
Z3AB	2159 (85)	1757 (69.2)	225 (8.9)	410 (16.1)
Z3BA	1794 (70.6)	1366 (53.8)	225 (8.9)	450 (17.7)
Z3BK	2437 (95.9)	2009 (79.1)	225 (8.9)	450 (17.7)

## Performance

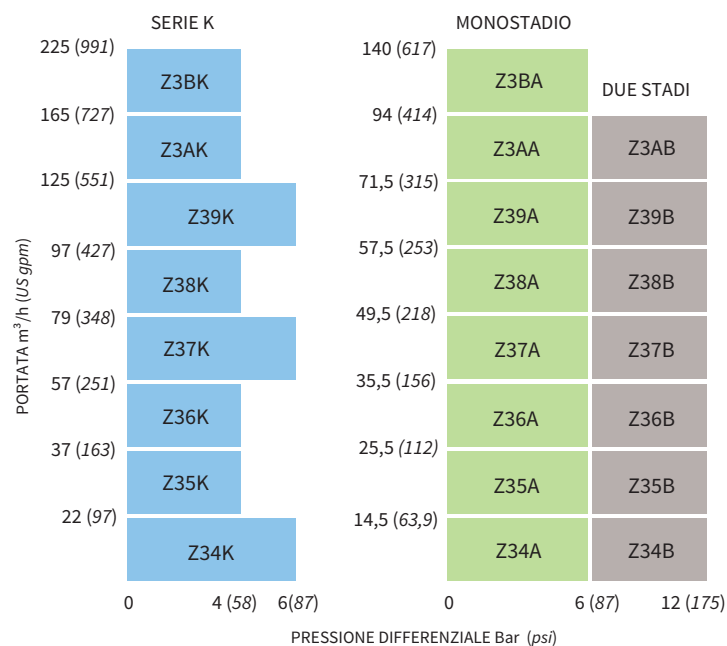

All dimensions are in mm (inches) and for guidance only.

