



Hydra Rig™ Cold Flow Manager

Control your coiled tubing wellhead safety equipment faster during your cold temperature operations.

A common safety challenge in cold temperature working conditions is maintaining hydraulic flow during operations. Our new, patent pending Cold Flow Manager (CFM) not only accelerates wellhead safety equipment operation, but it also requires minimal components and has a “plug and play” capability with existing equipment.

Our design is more affordable and dependable than other methods, and it’s unique simplicity makes it particularly practical. It supplies hydraulic flow from all of the pressurized control hoses on the well control power system and delivers it all to the one set of BOP rams selected. The high fluid viscosity due to low outside temperatures is overcome by the CFM’s focused flow.

We understand your need for quick BOP ram actuation. Adding only the CFM to the well control system, we have been able to increase flow **3 to 4 times** when compared to a standard BOP supply system. Further, adding relatively small accumulators to the supply and return sides of the CFM, allows a selectable flow increase of **up to 9 times flow**. This increased flow gives the ability to operate the BOP in cold temperatures with a timely response.

Features and benefits

- Reduced wellhead safety ram actuation time with standard fluids
- Retrofits to existing power systems, regardless of manufacturer, size, ram quantity and configuration
- Configured to improve performance for up to 8 rams and optimized for ram types
- Compact and light weight design: 100 lb (45 kg) manifold measuring 24" x 8" x 5" (610 mm x 203 mm x 127 mm)
- No external power source or changes to power system required
- Low leakage valves throughout
- Manufactured with proven and reliable components

Shear Ram Closing Test Results

Temperature	Typical CTU without CFM	8 Ram CFM	8 Ram CFM + 1 Accumulator	8 Ram CFM + 2 Accumulators
73° F (23° C)	18 seconds	6 seconds	5 seconds	4 seconds
65° F (18° C)	20 seconds	6 seconds	5 seconds	4 seconds
48° F (9° C)	29 seconds	10 seconds	7 seconds	5 seconds
31° F (0° C)	74 seconds	20 seconds	14 seconds	9 seconds
25° F (-4° C)	132 seconds	30 seconds	19 seconds	14 seconds
11° F (-12° C)	241 seconds	55 seconds	42 seconds	25 seconds

**Test results with simulated CTU, AW 46 hydraulic fluid and Texas Oil Tools™ 4.06 ES shear ram. Actual performance will vary based on installation and fluid used.*

Cold Flow Manager (CFM)

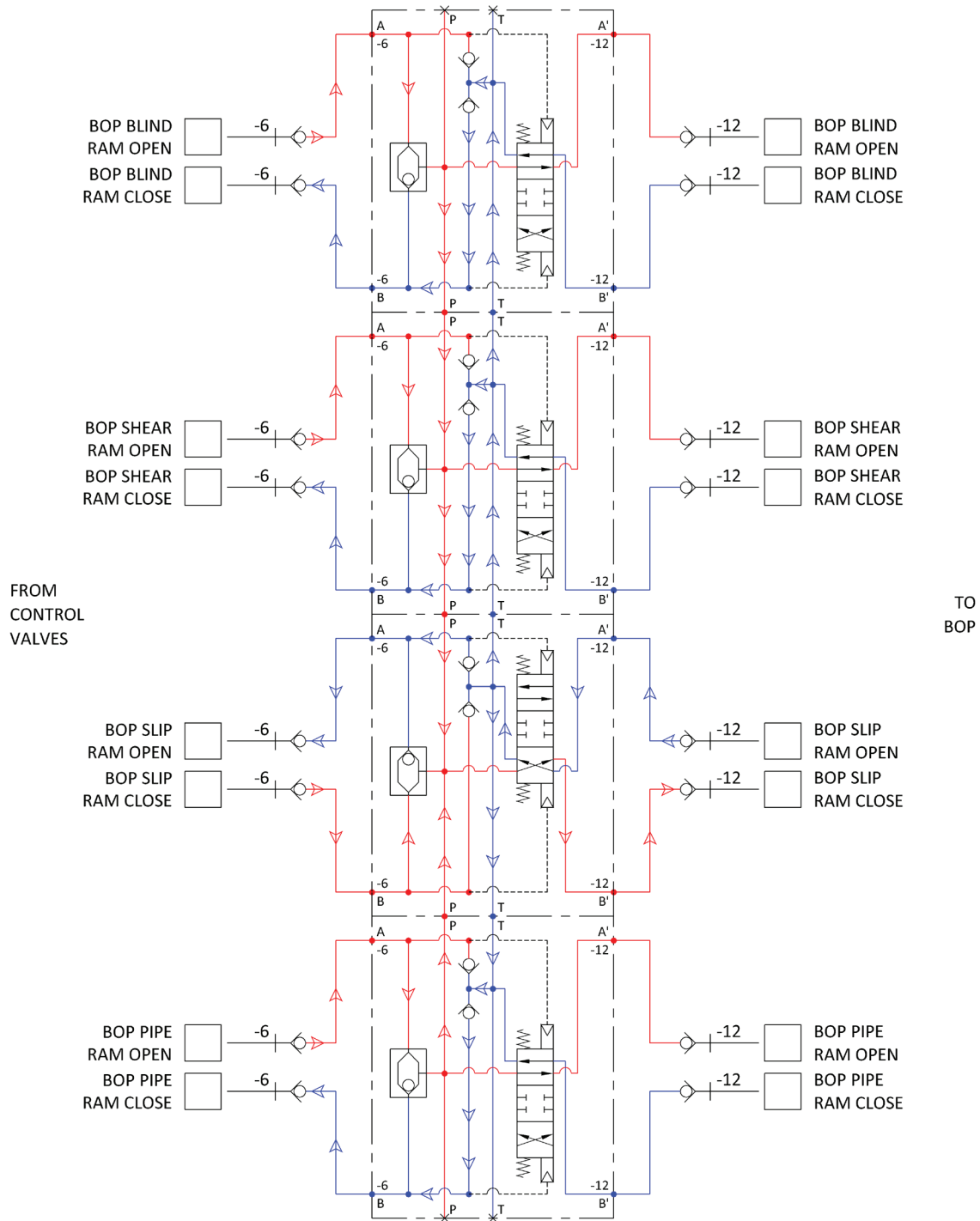

COLD FLOW MANAGER (CFM) ASSEMBLY
SLIP RAM CHANGING TO CLOSED
ALL OTHERS OPEN

PATENT PENDING