

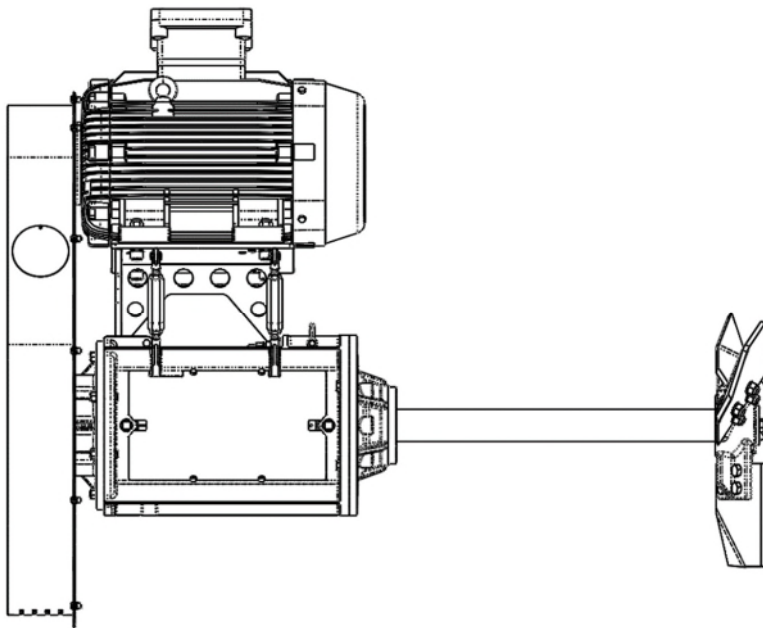

SB SIDE ENTRY MIXER

Installation, Operation, and Maintenance Manual

FIXED MOUNT MIXER



Document Number
640

Rev
01

Equipment Information:

This document contains proprietary and confidential information which belongs to National Oilwell Varco, L.P., its affiliates or subsidiaries (all collectively referred to hereinafter as "NOV"). It is loaned for limited purposes only and remains the property of NOV. Reproduction, in whole or in part, or use of this design or distribution of this information to others is not permitted without the express written consent of NOV. This document is to be returned to NOV upon request and in any event upon completion of the use for which it was loaned. This document and the information contained and represented herein is the copyrighted property of NOV. ©National Oilwell Varco

Mixing Technologies Headquarters
5870 Poe Ave.
Dayton, OH 45414
+1 937 454 3300
+1 800 643 0641
chemineer@nov.com



Contact Information

Tech Support

PFTService@nov.com or chemineerexpress@nov.com

24 Hour Hotline - (1)-937-454-3292

Mixing Technologies

Dayton Facility

5870 Poe Ave.

Dayton, OH 45414

+1 937 454 3300

+1 800 643 0641

chemineer@nov.com

United Kingdom Facility

Greengate, Middleton

Manchester, M24 1SA

+44 161 339 9000

chemineeruk@nov.com

China Facility

Building 4, 1250 Sicheng Road

Jiading District, Shanghai 201801

People's Republic of China

+86 21 6124

chemineercn@nov.com



Table of Contents

1	Side Entry Mixer Product Nomenclature	1
2	Initial Inspection.....	1
3	Safety.....	2
	3.1 Safety Symbols.....	2
	3.2 Vessels and Tanks	2
	3.3 Fasteners.....	3
	3.4 CE Marking (Where Applicable).....	3
	3.5 Safety Checklist.....	4
	3.6 Disposal.....	4
4	Storage	5
	4.1 Short-Term Indoor Storage.....	5
	4.2 Outdoor or Long-Term Storage	5
	4.3 Customer Responsibility	6
5	Mounting.....	7
	5.1 Floating Roofs on Tanks.....	7
	5.2 Nozzles.....	7
	5.3 Nozzle Loads	8
	5.4 Reinforcing Pads & Gusseting for Nozzles.....	9
6	Installation Information	11
	6.1 Installation of the Drive	12
	6.2 Installation of the Motor	13
	6.3 Installation of the Belt and Sheaves	14
	6.4 Installation of the Impeller	18
	6.5 Seal Lubrication System Installation.....	20
7	Operation	22
	7.1 Start-up Checklist.....	22
	7.2 Single Mechanical Seal Operation	23
	7.3 Double Mechanical Seal Operation	24
	7.4 Optional Mechanical Seal Plumbing.....	25
	7.5 Lubrication for Double Mechanical Seal Operation	26
	7.6 Troubleshooting.....	27
8	Maintenance	32



8.1	Motor Lubrication	32
8.2	Drive Bearing Lubrication	32
8.3	Seal Replacement	33
8.4	Mechanical Seal Disassembly	38
8.5	Mechanical Seal Assembly.....	39
8.6	Disassembling the Outboard Bearing Assembly.....	40
8.7	Assembling the Outboard Bearing Assembly	41
8.8	Installing the Outboard Bearing Assembly	42
8.9	Mechanical Seal Installation	42
8.10	Belt Drive	45
9	Item List for SB Mixer	47
10	Appendix	50

Table of Figures

Figure 1:	Tank Elevation View	7
Figure 2:	Tank Plan View.....	7
Figure 3:	Agitator Nozzle Loads	8
Figure 4:	Reinforcing Pad and Gussets	9
Figure 5:	Fixed Agitator Lifting Points	11
Figure 6:	Fixed Mixer Assembly (Belt guard Removed).....	12
Figure 7:	Impeller Rotational Installation	13
Figure 8:	Sheave Installation and Motor Plate Preparation	14
Figure 9:	Motor Bracket Fasteners	15
Figure 10:	Motor Sheave Alignment – Straight Edge.....	15
Figure 11:	Belt Installation/Adjustment.....	16
Figure 12:	Outer Guard Installation and Inspection Panel	18
Figure 13:	Impeller Blade Assembly, HE-3S.....	19
Figure 14:	Impeller Assembly, HE-3S.....	19
Figure 15:	Double Mechanical Seal Reservoir	21
Figure 16:	Mechanical Seal Assembly – Single.....	23
Figure 17:	Mechanical Seal Assembly – Double.....	24
Figure 18:	Mechanical Seal Assembly – Inlet & Outlet Plumbing	25
Figure 19:	Tank Shut-off System	34
Figure 20:	Tank Shut-off System.....	34
Figure 21:	Shaft Coupling Assembly	36
Figure 22:	Outboard Bearing Assembly.....	41
Figure 23:	Mixer Assembly with One Piece Impeller Shaft	44
Figure 24:	Mixer Assembly with Shaft Coupling	44
Figure 25:	Hub Flange-In Dismounting	46
Figure 26:	Hub Flange-Out Dismounting.....	46

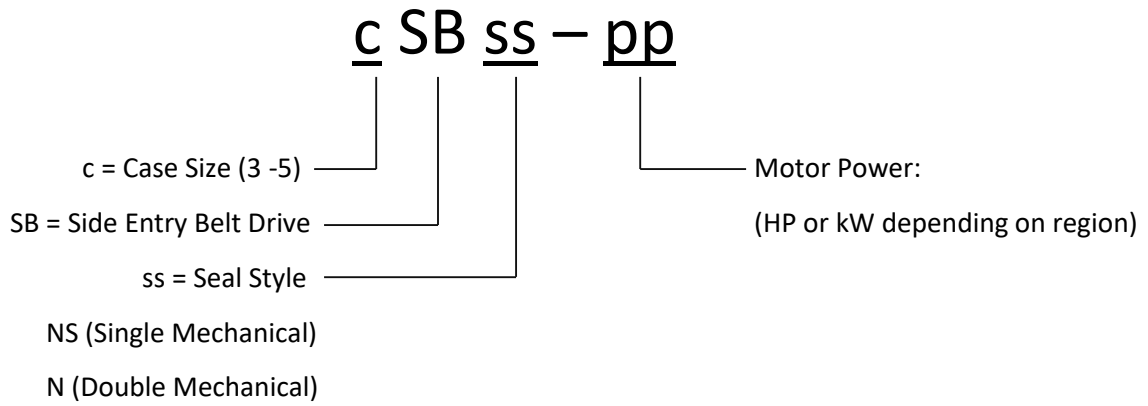

Table of Tables

Table 1: Reinforcing Pads and Gusset Design.....	10
Table 2: Agitator Weights.....	11
Table 3: Mixer Assembly.....	12
Table 4: Motor Drive Assembly.....	14
Table 5: Sheave Bushing Torque Values.....	15
Table 6: Belt Deflection.....	17
Table 7: Impeller Assembly.....	19
Table 8: Single Mechanical Seal Assembly.....	23
Table 9: Double Mechanical Seal Assembly.....	24
Table 10: Residual Process Fluid Volume.....	25
Table 11: Mechanical Seal Lubricants.....	27
Table 12: Trouble-shooting Guide – Motors.....	27
Table 13: Trouble-shooting Guide – Belts.....	28
Table 14: Trouble-shooting Guide – Bearings.....	29
Table 15: Trouble-shooting Guide – Bearings (cont'd).....	30
Table 16: Trouble-shooting Guide – Bearings (cont'd).....	31
Table 17: Recommended Initial Grease Volumes.....	33
Table 18: Recommended Replenishment Grease Volumes.....	33
Table 19: Tank Shut-off System.....	34
Table 20: Bolt Tightening Torque.....	50
Table 21: Bolt Tightening Torque (Contd.).....	51
Table 22: Bolt Grades and Mechanical Properties.....	52



1 Side Entry Mixer Product Nomenclature



Note: Rarely, other nomenclature may be used for custom designs as needed.

2 Initial Inspection

Step 1: Inspect crates. Upon receipt, inspect all crates and equipment for any damage during shipping. If you observe any damage, please report it to your NOV contact. A claim should be filed immediately with the carrier involved.



Step 2: Uncrate. Check the contents. Do not un-crate the unit until you have read all the Installation instructions and viewed the assembly drawing shipped with the unit. Be careful in uncrating and handling. Before discarding the crating, make sure that all agitator parts have been removed. Correct assembly of this unit requires referring to both the unit assembly drawing and this manual.

Step 3: Questions? Call NOV. If the shipment is not complete or you do not understand what you have received, please contact your NOV office immediately.

3 Safety

3.1 Safety Symbols

Please always observe the following safety and information symbols!

	<p>Danger! Risk of fatalities and injury</p>
	<p>Attention! Machine may be damaged</p>
	<p>Note! Useful information</p>

All work including transportation, storage, installation, electrical connection, commissioning, servicing, maintenance and repair must be performed only by qualified specialist personnel.

	<p>Danger! Installation and maintenance work may only be performed when units are at a standstill. The motor must be isolated and secured to prevent accidental start-up.</p>
--	--

Eyebolts on motors are only intended for lifting the motors. **Do not** attempt to do any lifting of the agitator using the motor eyebolts, even when in combination with other lifting slings or eye bolts.

Observe all safety information, including that provided in the individual sections of this Operating Manual. All national and other regulations on safety and accident prevention must also be observed.

	<p>Danger! Serious physical and property damage may result from inappropriate installation, non-designated use, incorrect operation, non-compliance with safety information, unauthorised removal of housing components or safety covers, and structural modifications to the unit.</p>
---	--

3.2 Vessels and Tanks

All types of vessels or tanks either open or closed pose special safety challenges. It is essential that Installers, Operators and Maintainers of the equipment understand these special hazards.

Particular safety hazards arise because the vessel is typically defined as a “Confined Space”. This creates a number of special hazards, including the risk of having oxygen shortages. Never enter a confined space unless you are fully trained on the procedures and have the correct safety equipment and procedures in place.



One must not enter a confined space unless fully assured that it is safe. Typically, before entering a vessel you should require proof of power and process fluid lock out. Always carry with you an oxygen sensor (in order to verify a safe atmosphere), a suitable safety harness, and lifting equipment. Typically, a shoulder lift harness and a man-lifting crane are required (a man on the end of a rope or a centre back lift offers no safety protection). A suitable safety cover must be provided at all time.

In cases where a vessel has been in service, tests must be made to ensure that no hazardous products or product residues are present.

The work site is often within a designated hazardous area. Where potentially explosive conditions exist, all efforts must be made to make the area safe before proceeding with work. Where this is not possible, a detailed, individual hazard assessment is vital. Special working procedures and tooling are required.

3.3 Fasteners

Important fasteners should not be re-used. When a fastener is disturbed, always replace it with a new one. Dispose of used fasteners. Do not keep them for re-use.

3.4 CE Marking (Where Applicable)

Any CE Marking and associated documentation applies to the mixer only on the basis that it is an individual product. After installation of the mixer into the mixing system, it becomes an integral part of a larger installation. **NOV is not responsible for the CE marking once the mixer has been installed into the mixing system.** As a standard, the mounting flange has been designed for the design conditions stated on the arrangement drawing and a fibre flange gasket (supplied by others). Where other conditions apply, they will be stated on the assembly drawing.



3.5 Safety Checklist

- ☑ This Installation, Operation and Maintenance Manual, assembly drawings, and any supplements must be reviewed and understood before commencing installation and operation.
- ☑ All site rules must be observed for the installation and operation of this mixer.
- ☑ Ensure all external connections are made in accordance with applicable codes of practice.
- ☑ The mixer must be earthed (connected to ground).
- ☑ Correct rotation must be checked prior to operation.
- ☑ **Do not** exceed the operating pressures, temperatures, and other conditions for which the machine has been designed.
- ☑ **Do not** operate the agitator unless all guards are securely fixed. Do not modify any guarding.
- ☑ **Do not** touch rotating components.
- ☑ During servicing of the mixer, the motor must be isolated from the power supply and the supply locked out.
- ☑ **Do not** operate the mixer for applications other than for its intended use.
- ☑ **Do not** modify the mixer without reviewing the change with NOV. It is unsafe to use non-standard parts without NOV approval. When in doubt, ask your local Mixing Technologies office.

WHEN IN DOUBT, ASK!

3.6 Disposal

Observe the current local regulations. In particular, lubricants must be collected and disposed of correctly.



4 Storage

Do not remove protective coatings until the agitator is to be put into service. If the shipment is to be stored, do not stack crates. Store in a clean dry location, which is free from wide variations in temperature. The storage area should be free from vibration and excessive heat.

At six-month interval, inspect for external rust. Apply rust preventative as required. If the unit has been in storage for more than six months or subjected to adverse moisture conditions, the motor windings may have to be dried prior to operation.

4.1 Short-Term Indoor Storage

Agitators should be stored indoors in areas with no vibration and relatively constant temperatures and humidity. The factory storage preparations are acceptable for up to nine months storage. If the storage period will exceed nine months, see the Long-Term Indoor Storage section. The following precautions should be followed:

- Store the agitator in the running position and secure the unit against falling
- Lightly grease bare metal housing surfaces and shafts to prevent against rust
- Store in a dry room
- Temperature must not fluctuate beyond the range of -5°C [23°F] to $+40^{\circ}\text{C}$ [104°F]
- Relative humidity less than 60%
- No direct exposure to sunlight or UV light
- No aggressive, corrosive substances (contaminated air, ozone, gases, solvents, acids, alkalis, salts, radioactivity etc.) in the immediate vicinity
- No vibration or oscillation

4.2 Outdoor or Long-Term Storage

Storage of agitators and motors outdoors is not recommended. If a unit is stored for an extended period indoors, stored outdoors or decommissioned, the following recommendations apply:

- Rotate the motor and drive shafts 10 to 15 revolutions at least once per month to reduce the possibility of damaging the bearings.
- Motor space heaters, if installed, should be energized during the storage period.
- Apply rust preventive to unpainted steel surfaces to prevent corrosion.
- The unit should be covered to prevent damage by the elements, but still allow free air circulation.

The method employed for long-term storage is to prevent the humidity/temperature changes and airborne chemicals from making contact with the internal components of the equipment.

The methods described below provide protection but cannot avoid some level of degradation of the equipment.

- Store in the running position and secure unit against falling.
- Transportation damage to the external paint must be repaired. Check that a suitable rust inhibitor is applied to the bearing surfaces. If necessary, apply a suitable rust inhibitor to the surfaces.
- Store in a dry place.
- In tropical regions, the agitator must be protected against damage by insects
- Temperature must not fluctuate beyond the range of -5°C [23°F] to $+40^{\circ}\text{C}$ [104°F]
- Relative humidity less than 60%



- If the relative humidity is <50% the unit can be stored for up to 3 years.
- No direct exposure to sunlight or UV light
- No aggressive, corrosive substances (contaminated air, ozone, gases, solvents, acids, alkalis, salts, radioactivity etc.) in the immediate vicinity
- No vibration or oscillation

Measure before commissioning the Agitator

- If the storage or standstill period exceeds 2 years or the temperature during short-term storage greatly deviates from the standard range, the grease must be replaced before commissioning.

4.2.1 To prevent corrosion:

Extreme temperatures can cause the grease volume to change. Lost grease may need to be replaced during colder times to avoid corrosion.

4.2.2 To protect elastomers:

Elastomers will age, can stick or take set. In order to prevent the elastomers from sticking, regularly rotate shafts in order to redistribute lubricants. Protect the equipment from direct sunlight and from ozone to minimize the rate of aging of the elastomers.

4.2.3 To avoid false brinelling:

Rotate the motor and mixer shaft 10 to 15 revolutions at least once per month to reduce the possibility of false brinelling of the bearings and to re-distribute bearing grease.

Other problems include vibration related damage. Do not store equipment in a manner that subjects it to vibration.

Motor space heaters, if installed, should be energized during the storage period

	Note!
	When the equipment is to be stored in a strong chemical environment or near salt-water, protection procedures should be executed immediately upon receipt of the equipment.

4.3 Customer Responsibility

To ensure the original quality of the NOV equipment prior to commissioning after storage, all components must be inspected by an authorized NOV Service Engineer. Any sub-assemblies not manufactured by NOV must be inspected by that part supplier/manufacturer's authorized service personnel. NOV is not responsible for the cost of such a service.

Because storage location and other unknown site factors are beyond NOV's control, NOV will not accept any liability for damage to the equipment during the storage period.

5 Mounting

5.1 Floating Roofs on Tanks

Some tanks have floating roofs that float up and down with the fluid level in the tank. If this is the case, it is imperative that there be positive stops for the roof that keep the bottom of the roof or any roof supports a distance of at least 1.5x the impeller diameter (ϕD in Figure 1) above the shaft centerline to prevent the roof from accidentally contacting the mixer, and to maintain process performance.

5.2 Nozzles

Unless otherwise specified, the agitator nozzle should be oriented as shown in Figure 1 and Figure 2. The shaft centerline (H_{min}) should be located one (1) impeller diameter (ϕD) from the tank bottom, meaning $H_{min} = D$. The agitator nozzle should be level to within $\pm 1^\circ$.

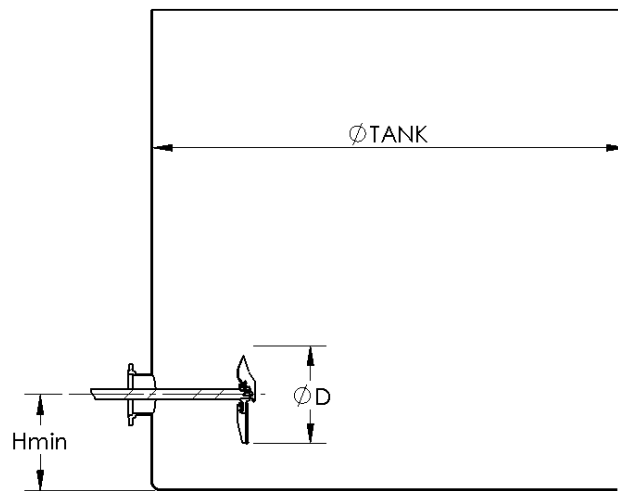

Figure 1: Tank Elevation View

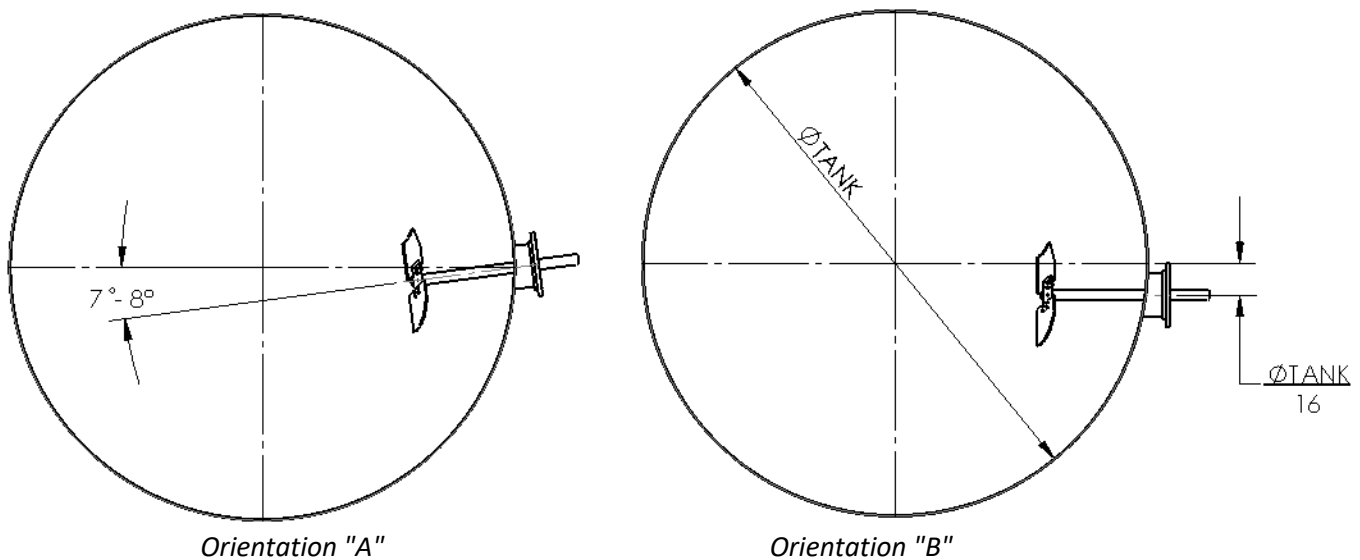

Figure 2: Tank Plan View

5.3 Nozzle Loads

	<p>Attention!</p> <p>A final check should be made of the mounting nozzle for orientation, strength and rigidity. Inadequate strength and/or rigidity may allow excessive movement of the agitator and vessel deflection.</p>
--	---

The nozzle and vessel combination should be rechecked for strength and rigidity. The nozzle strength should be such that the maximum operating stresses will not exceed the fatigue limit of the material used. The nozzle rigidity should be designed so that the dynamic deflection is less than 1/64 inch per foot (1.3 mm per meter) of nozzle extension. Note that some API tanks are not designed for the loads induced by agitators, so extra reinforcement may be necessary to reduce issues from insufficient stiffness.

Side entering agitators impose four different types of loads on the supporting structure: torque, thrust, bending moment, and vertical downward force (weight).

Figure 3 illustrates these loads pictorially. The bending moment will constantly change direction due to the mixing forces, so it should be analyzed in the worst-case orientation for your nozzle. The other three loads can be considered constant loads while the mixer is operating unless the motor is on a VF drive that will change the speed at times. See the general arrangement drawing for the exact design loads for your mixer.

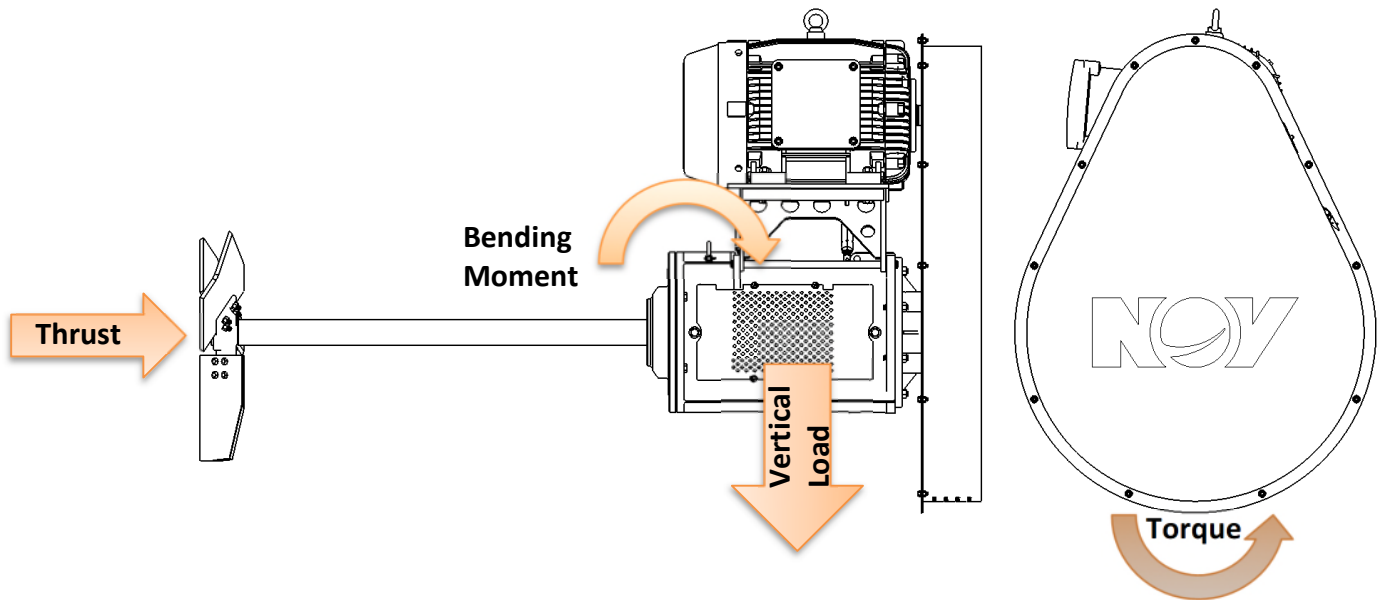

Figure 3: Agitator Nozzle Loads

5.4 Reinforcing Pads & Gusseting for Nozzles

Unless otherwise specified, use reinforcing pads and gussets to reduce the nozzle area stresses and provide rigidity. Figure 4 illustrates a typical design recommendation. Refer to Table 1 for pad and gusset design details for simple tank geometry. Trim the reinforcing plate near the tank floor as required. Gusset plate thickness is $t/2$ minimum. For 10" or 12" flanges, four (4) gussets at 90° as shown is recommended. For larger or custom flanges, more gussets equally spaced will be required. More complicated tanks will require custom calculations for these values, and the table values may not be applicable. It is the responsibility of the customer or tank designer to verify that the guidelines provided are adequate in terms of stress and stiffness for each installation and each mixer. Use the loads provided on the agitator general arrangement drawing to verify the nozzle design.

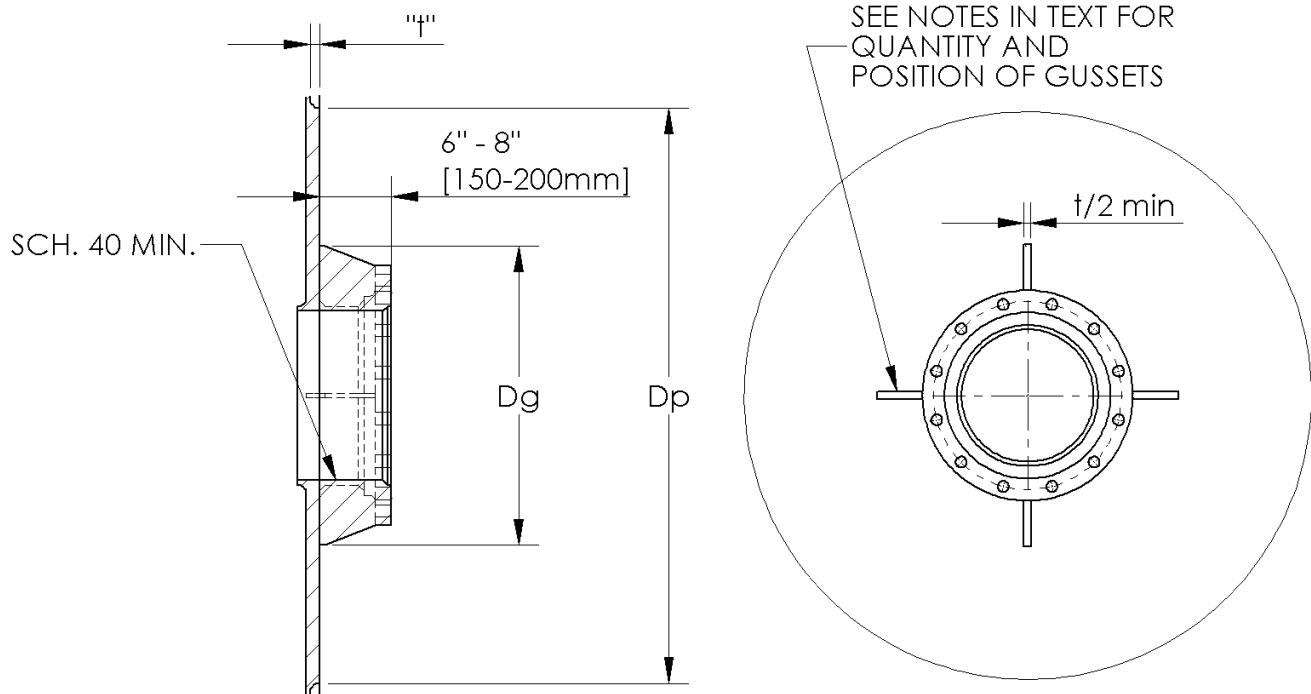

Figure 4: Reinforcing Pad and Gussets



Table 1: Reinforcing Pads and Gusset Design

ASME Flange Size:	10"			12"						Units
	Case Size: 3			4			5			
Tank Diameter (ft)	t (in)	dg (in)	dp (in)	t (in)	dg (in)	dp (in)	t (in)	dg (in)	dp (in)	Imperial
12	5/8	27	30	7/8	41	38	7/8	41	45	
18	3/4	27	38	7/8	41	52	7/8	41	60	
24	3/4	27	38	1	41	52	1	41	60	
30	3/4	27	45	1	41	60	1-1/8	41	60	
36	7/8	27	45	1-1/8	41	60	1-1/8	41	60	
42	7/8	27	45	1-1/8	41	60	1-1/4	41	68	
48	7/8	27	45	1-1/8	41	60	1-1/4	41	68	
54	7/8	27	45	1-1/8	41	72	1-1/4	41	80	
60+	1	27	45	1-1/4	41	72	1-3/8	41	80	

ASME Flange Size:	10"			12"						Units
	Case Size: 3			4			5			
Tank Diameter (m)	t (mm)	dg (mm)	dp (mm)	t (mm)	dg (mm)	dp (mm)	t (mm)	dg (mm)	dp (mm)	Metric
4	15	685	900	20	1,040	1,100	20	1,040	1,300	
6	20	685	900	25	1,040	1,300	25	1,040	1,500	
8	20	685	900	25	1,040	1,500	30	1,040	1,500	
10	20	685	1,100	25	1,040	1,500	30	1,040	1,500	
12	20	685	1,100	25	1,040	1,900	30	1,040	1,900	
14	25	685	1,100	25	1,040	1,900	30	1,040	1,900	
16	25	685	1,100	30	1,040	1,900	30	1,040	2,000	
18	25	685	1,100	30	1,040	1,900	35	1,040	2,000	
20+	25	685	1,100	30	1,040	1,900	35	1,040	2,000	



6 Installation Information

To allow easier shipment, some agitators may require minor assembly during installation, such as installing the motor, belt guard, and the impeller. Review the assembly drawings provided with each order for more details, as well as any special instructions which may not be covered by this manual.

	Danger!
	Read all tags and instructions before installation and start-up.

Exercise caution while handling the agitator to avoid damage to the shaft or mating components. **Do not** lift or support the unit by the shaft or motor. Remove all shipping restraints from the agitator (crate, straps, etc.). Remove the impeller from the shaft only if required for installation into the tank nozzle. Lift the agitator using a hoist or crane system, approximate weights for the complete assembly are listed in Table 2.

Table 2: Agitator Weights		
Case Size:	(lb.)	(kg)
3SB	1,222	554
4SB	1,703	773
5SB	2,269	1,029

Slings should be placed under the pedestal for lifting the agitator. There is also an extra lifting shackle provided if using slings around the pedestal are not practical because of site conditions. For some motor sizes, the center of gravity may make using the shackle on the mixer as the only lifting point impractical.

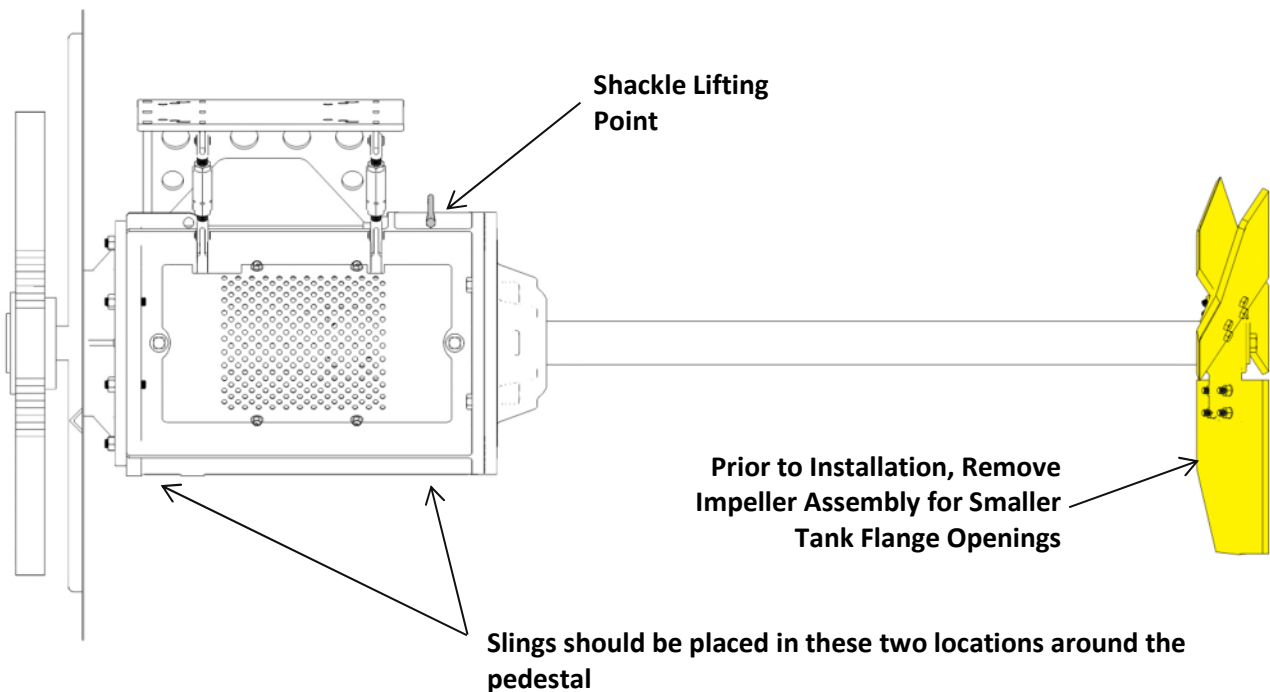

Figure 5: Fixed Agitator Lifting Points



6.1 Installation of the Drive

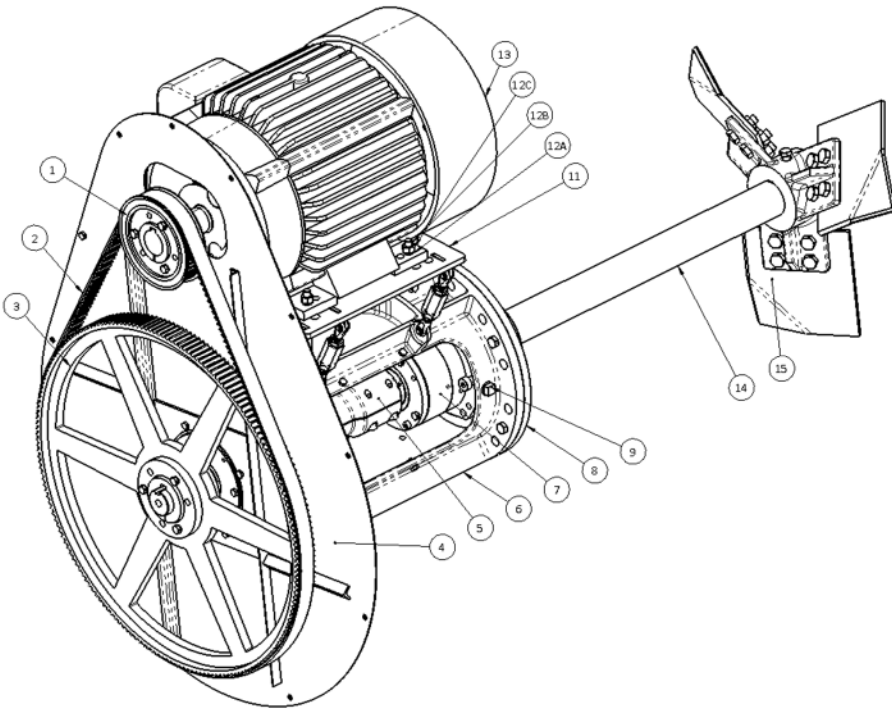

Table 3: Mixer Assembly		
Item No.	Description	QTY
1	Motor Sheave	1
2	Drive Belt	1
3	Impeller Sheave	1
4	Belt Guard	1
5	Shaft Coupling (optional)	1
6	Pedestal	1
7	Seal Assembly	1
8	Mounting Flange	1
9	Plug, Plumbing Access	4
10	Pedestal Guard (not shown)	2
11	Motor Mount	1
12	Motor Fasteners	12
13	Motor	1
14	Impeller Shaft	1
15	Impeller	1

Figure 6: Fixed Mixer Assembly (Belt guard Removed)

1. Remove the outer belt guard, belt, and motor [30 (Figure 6), 2, 13] as necessary to ease installation. Note that small flange openings may require removal of the impeller [15] prior to agitator installation. For larger flange openings, the impeller can remain installed on the shaft by carefully rotating the shaft as the impeller passes through the tank flange opening. Verify the torque value on the set screw [29 (Figure 14)] and washer bolt [26 (Figure 14)] prior to installation if the hub will not be removed. See Figure 7.

i	Note!
	The impeller assembly may be removed and installed inside the tank for smaller flange openings. In some cases, you can rotate the shaft to install the impeller without removing it from the shaft as shown in Figure 7.

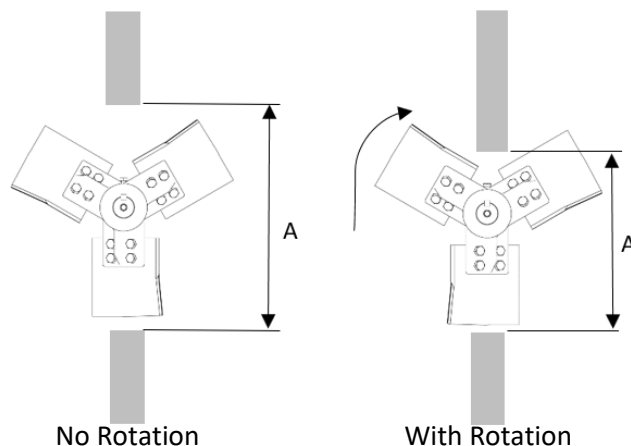



Figure 7: Impeller Rotational Installation

- Lift the agitator with the provided lifting points as shown in **Figure 5**. Stabilize the load as needed by either removing the motor or belt guard, or by adjusting the lifting point or strap lengths to help align the shaft horizontal with the ground during mounting.

	Note!
	Ensure that the agitator mounting flange and vessel nozzle are clean; free of nicks and scratches, and the gasket (furnished by others) is properly located. Note: Unrestrained cold flowing gasket materials must be used to seal the agitator to the vessel.

- While fully supporting the agitator, place the gasket (normally customer supplied) between the tank and pedestal flanges. The flange studs or bolts can help support the gasket. Insert the mixer shaft into the nozzle opening and carefully position the flanges. Install all flange fasteners and torque according to the instructions and torque values provided by the tank manufacturer.
- Some agitators have provisions for a floor support or a set of tie rods to be field located and fitted. The floor support should be bolted to a concrete pad and shimmed to insure proper fit. See the assembly drawing for specific details. Do not raise or lower the mixer unit using the support. Shim the base support as necessary for proper alignment and torque fasteners to the values recommended in the Appendix, page 50.

	Note!
	In cases where the support structure is a concrete pedestal, fill the area between the base plate and pedestal with grout. Allow enough time for the grout to harden before proceeding with assembly work or operation.

- The lift supports can now be carefully removed.

6.2 Installation of the Motor

- Using the motor's nameplate data, verify the motor voltage requirements match the available power supply. The power supply should be of proper size to safely carry motor loads and include a circuit interrupt device to protect against overloads. Ensure installation complies with suitable electrical code(s) and local requirements (NEC, DIN VDE, IEC 60364, etc.).
- Turn the motor shaft by hand to ensure it turns freely.
- If motor has been stored in a damp location, the windings may require drying.
- Install motor **[13 (Figure 6)]** onto motor mount **[11]**, and secure using supplied fasteners **[12A, 12B, 12C]**. Torque in an alternating pattern to the value specified in the Appendix, page 50.
- Connect motor's electrical connections ensuring compliance to local codes. Do not make connections permanent until the motor rotation has been verified. Ensure adequate cable free length and clearance for mixer with swivel feature.

6. Identify motor auxiliary devices and space heaters or temperature sensors and connect them to the proper circuits and insulate from power cables.
7. Jog the motor to verify proper motor rotation. Unless otherwise specified, the motor rotation is counterclockwise when viewed from the motor's fan end.

	Danger!
Do not jog motor with belt attached unless the mechanical seal chamber has been filled with fluid and properly vented. Dry running of mechanical seal may significantly shorten seal life.	

6.3 Installation of the Belt and Sheaves

1. Ensure that the sheave (sprocket) bore, bushing mounting surfaces and motor shaft are clean and free of any debris, burrs, grease, rust inhibitor, etc.
2. Install key into motor shaft keyway and install motor sheave bushing **[1A]** onto motor shaft/key. Install the bushing's flange, or the largest taper diameter, facing the motor in most cases. Some motor shaft lengths may require the reverse configuration.
3. Slide the motor sheave **[1B]** onto the motor sheave bushing **[1A]** and align the drilled holes in the motor sheave with the tapped holes in the sheave bushing.
4. Next, loosely install the bolts and lock washers **[1C, 1D]**. The motor sheave assembly should slide along the motor shaft until tightened.
5. Do the same installation for the extension shaft sheave **[3A]**, bushing **[3B]**, and fasteners **[3C, 3D]**. Again, some will fit better with flange out, others with flange in depending on the motor shaft length.

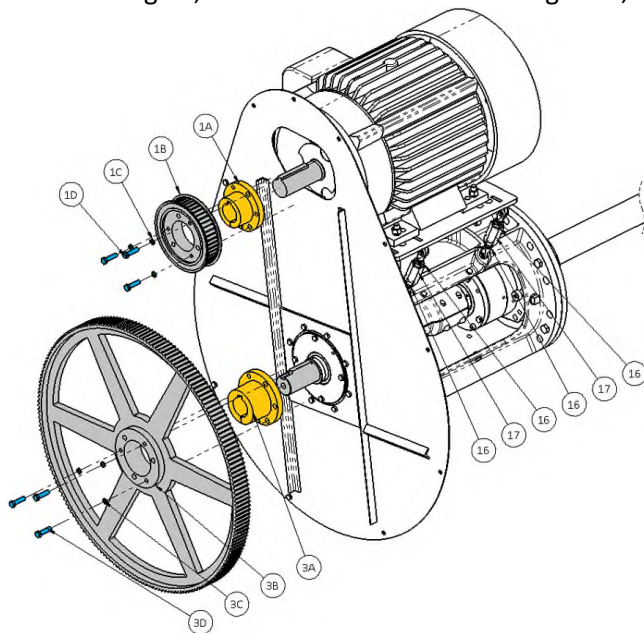

Table 4: Motor Drive Assembly		
Item No.	Description	QTY
1A	Bushing, Sheave Motor	1
1B	Sheave, Motor	1
1C	Lock Washer	Varies
1D	Bolt	Varies
3A	Bushing, Sheave Ext. Shaft	1
3B	Sheave, Ext. Shaft	1
3C	Lock Washer	Varies
3D	Bolt	Varies
16	Hex Jam Nut	4
17	Turnbuckle	2

Figure 8: Sheave Installation and Motor Plate Preparation

	Danger!
	<p>Do not apply never-seize or lubricant to the taper or bore faces of any of the sheaves or bushings. This will allow the bushings to slip under the motor load.</p> <p>Do not apply thread lubricant to the bushing fasteners.</p>

- Loosen the outer turnbuckles' hex jam nuts [16]. Loosen the hex bolt and nut [18, 19] where the bracket meets the pedestal. Rotate the turnbuckle bodies [17] to retract motor bracket down until there is enough clearance for the drive belt installation.

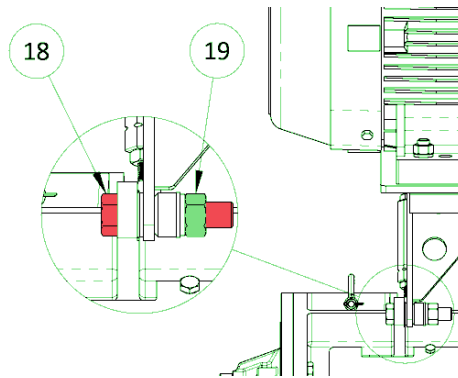

Figure 9: Motor Bracket Fasteners

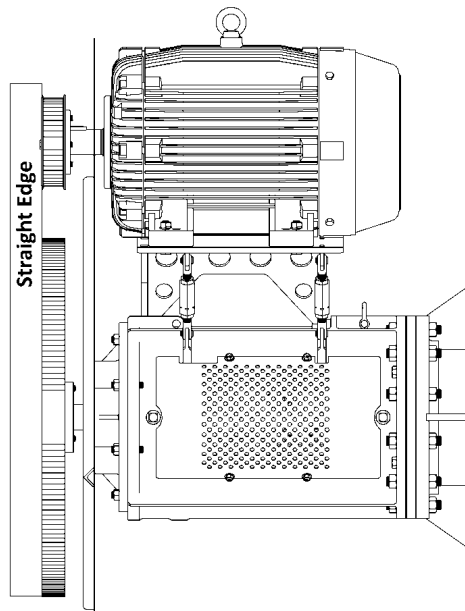

Figure 10: Motor Sheave Alignment – Straight Edge

Table 5: Sheave Bushing Torque Values		
Bushing Type	Torque Values	
	N-m	ft-lbs.
SDS	12	9
SK	20	15
SF	41	30
TL	49	36
E	81	60
F	149	110
<i>Do Not Lubricate Fasteners</i>		

- Align the two sheaves [1B, 3B] using a straight edge placed across the outside surface of both sheaves, located at the widest possible areas. The Straight edge should make contact at four different points, two points on each sheave. In cases where one sheave is wider than the other, try to center the belt on the wider sheave.
- Tighten each screw [1D, 3D] in an alternating pattern. Apply torque as listed in Table 5 on page 15. Ensure the threads on the bushing fasteners **are not lubricated**. The bushing type is etched on the bushing by the manufacturer. If your mixer does not use the standard bushing types because of customer preference, then consult the documentation that came with your bushings.

9. Install belt **[2]** onto sheaves **[1B, 3B]**, starting with the motor sheave first. The belt should slip onto the lower sheave. If not, shorten the turnbuckle length as necessary.
10. After the belt is installed, extend the turnbuckles **[17]** until the belt feels snug or taut. Avoid over tensioning the belt.
11. From **Figure 11** determine the deflection required for the belt. The deflection height is $1/64''$ per inch of span (15.6mm/m). For example, a 32" span length requires a deflection of $32/64''$ or $1/2''$. To measure the deflection height, place a straightedge from sprocket to sprocket on top of the belt or wrap a string or steel tape around the sprockets on top of the belt.
12. See Table 6 for minimum and maximum force values.

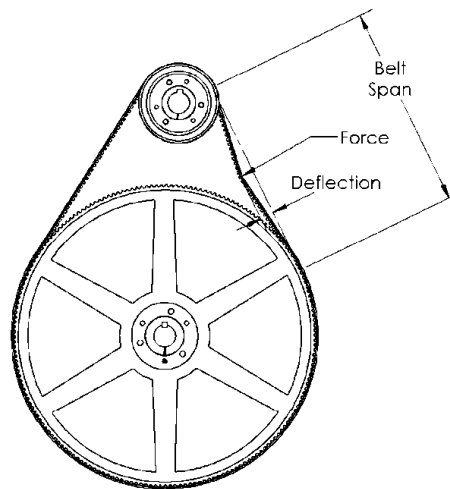

Figure 11: Belt Installation/Adjustment

13. Using a spring scale, apply a perpendicular force to the belt at the mid-point of the span as shown in **Figure 11**. For belts wider than 2 inches (50 mm), it is suggested that a rigid piece of key-stock or something similar be placed across the belt between the point of force and the belt to prevent distortion. Compare this deflection force value to that found in Table 6 and adjust the tension accordingly.

	Note!
	Actual belt installation tension required depends upon many factors (peak loads, system rigidity, teeth in mesh, etc.). In some instances, it may be necessary to gradually increase the belt tension to achieve proper drive operation.

14. Spin the mixer shaft by hand for several revolutions to ensure the belt is not slowly walking off the sheave. If it does not stay centered, then adjust the turnbuckles as needed until the belt will stay centered.
15. Tighten the turnbuckles' hex jam nuts **[16]** to hold the turnbuckles in position. Remove all slack, and secure using both lock nuts.
16. Re-tighten the hex head bolt and nut **[18, 19]** where the motor bracket meets the pedestal to the values shown in the Appendix, page 50.



Table 6: Belt Deflection

Case Size	Motor Power (hp)	Motor Speed (RPM)	Motor Frame Size (4 pole)	Motor Sheave Pitch Dia. (in)	Est. Belt Span (in)	Estimated Deflection (in)	Maximum Deflection Force (lbf)	Minimum Deflection Force (lbf)
3	10	1800	215T	4.81	23.3	0.34	7.8	6.4
	15	1800	254T	4.81	23.3	0.34	11.1	9.1
	20	1800	256T	4.81	23.3	0.34	15.1	12.3
	25	1800	284T	4.81	23.3	0.34	18.4	15.1
	30	1800	286T	4.81	23.3	0.34	21.7	17.8
4	25	1800	284T	6.32	28.8	0.42	16.0	12.9
	30	1800	286T	6.32	28.8	0.42	18.5	15.0
	40	1800	324T	6.32	28.8	0.42	23.5	19.2
5	50	1800	326T	8.42	25.9	0.35	22.6	18.6
	60	1800	364T	8.42	25.9	0.35	27.8	22.8
	75	1800	365T	8.42	25.9	0.35	33.5	27.5
Case Size	Motor Power (kW)	Motor Speed (RPM)	Motor Frame Size (4 pole)	Motor Sheave Pitch Dia. (mm)	Est. Belt Span (mm)	Estimated Deflection (mm)	Maximum Deflection Force (N)	Minimum Deflection Force (N)
3	7.5	1500	132M	142.5	578.1	8.6	35.5	28.9
	11	1500	160M	142.5	578.1	8.6	50.8	41.6
	15	1500	160L	142.5	578.1	8.6	65.8	54.1
	18.5	1500	180M	142.5	578.1	8.6	83.7	68.6
	22	1500	180L	142.5	578.1	8.6	98.8	81.2
4	18.5	1500	180M	151.6	692.2	10.4	85.1	69.2
	22	1500	180L	151.6	692.2	10.4	99.5	81.1
	30	1500	200L	151.6	692.2	10.4	133.1	108.5
5	37	1500	225S	285.2	686.6	9.1	94.0	77.3
	45	1500	225M	285.2	686.6	9.1	109.1	89.8
	55	1500	250M	196.1	706.9	10.4	185.5	152.5

Belt Service Factor = 1.8 minimum

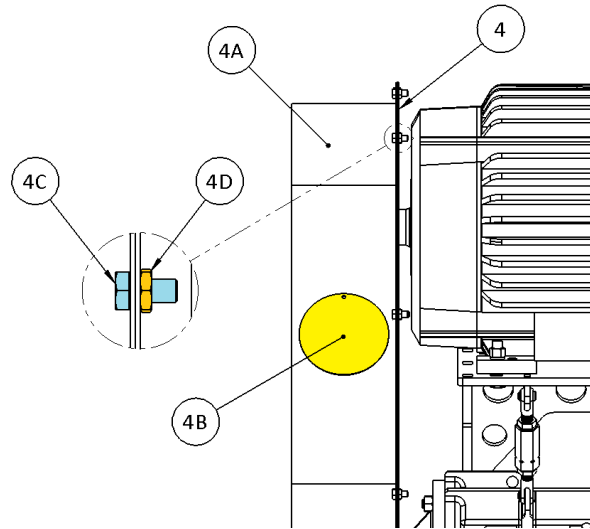

Figure 12: Outer Guard Installation and Inspection Panel

17. Reinstall the outer belt guard **[4A]** and secure using supplied hardware **[4C, 4D]**.
18. Use access panel **[4B]** to visually inspect for adequate clearance for sheaves and belt.
19. Also use the access panel to check the new belt tension at least twice during the first day's operation and adjust as required. Normally, a rapid decrease in belt tension will occur until the belt(s) have run in.

6.4 Installation of the Impeller

1. Impeller installation begins by installing the impeller blades to the hub. Impeller blades are a matched set. Arrange as marked so impeller is properly balanced. Fasten blades **[24 (Figure 13)]** to the hub **[23]** using supplied hardware **[21, 22, 25]** and torque to the values in the Appendix, page 50.
2. Place the key **[28 (Figure 14)]** into shaft's keyway and slide the impeller assembly onto shaft **[14]**. Orient the blades so the concave side points away from vessel wall. Secure the impeller hub **[23]** using the setscrew **[29]** and torque to the value shown in the Appendix, page 50.
3. Install secondary retention washer and hex bolt **[26, 27]** and torque to the value shown in the Appendix, page 50.

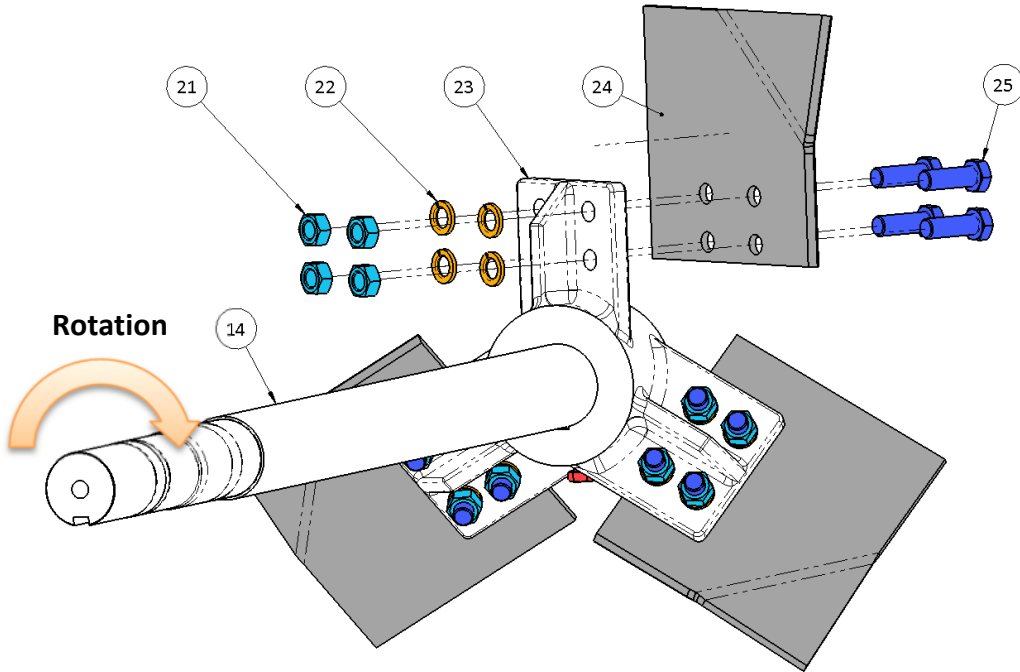

Table 7: Impeller Assembly		
Item No.	Description	QTY
14	Shaft	1
21	Hex Nut	12
22	Lock Washer	12
23	Hub	1
24	Blade	3
25	Hex Bolt	12
26	Hex Bolt	1
27	Flat Washer	1
28	Key	1
29	Set Screw	1

Figure 13: Impeller Blade Assembly, HE-3S

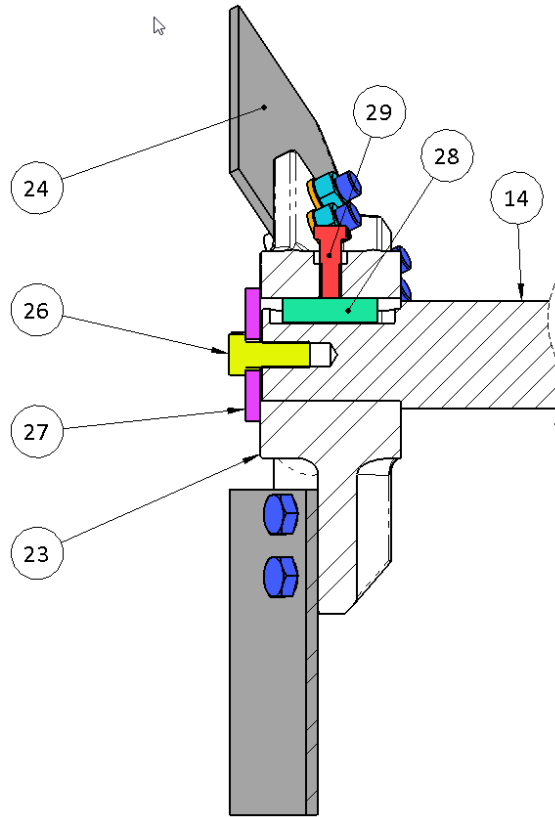



Figure 14: Impeller Assembly, HE-3S



6.5 Seal Lubrication System Installation

If the bracket and lubrication reservoir are supplied by NOV, the lubrication bracket may ship separately because of its height. If this is the case for your mixer, below are the instructions for how to install the NOV supplied bracket. Refer to **Figure 15**. Additional operation information is available in section 7.5, “Lubrication for Double Mechanical Seal Operation”, on page 26.

1. Assemble the supplied bracket to the mixer. The seal support bracket is designed to be mounted on either side of the mixer. It should be installed at the most convenient spot that does not have interference from wiring, tie rods, or any other site obstructions. The motor adjustments are on the right-hand side of the mixer; therefore, the preferred mounting location is on the left-hand side for convenience.
2. Assemble the lubricator mounting bracket to the lubrication reservoir if not already done so. Install the supplied U-bolts around the support pipe and tighten one set of nuts against the flat brackets. Do not fully torque the nuts yet because you may need to adjust the angle or height of the reservoir to avoid obstructions.
3. Install the lubricator reservoir to the ends of the U-bolts. Do not fully torque the nuts at this time but secure them enough that the lubricator pot will not slide down. The outlet port on the seal lubrication reservoir should be at least 24” (60cm) above the centerline of the mixer shaft.
4. Connect the supplied fittings to the mechanical seal, and then attach the flexible hoses to the mechanical seal. There are two different length hoses supplied. The longer hose will go from the reservoir to the far side of the mixer.
5. Trial fit the hoses to make sure they both reach the reservoir. Once you are sure that the lubrication reservoir is at the correct height and orientation, fully torque the bolts for the lubrication bracket and torque the nuts for the reservoir. Be sure to first torque the nuts that are behind the lubrication bracket that clamp the U-bolt to the pipe, and only after they are fully torqued should you then torque the nuts that clamp the reservoir to the U-bolt. Torque values can be found in the Appendix, page 50.
6. Connect the flexible hoses to the reservoir.
7. Fill the mechanical seal lubricator reservoir to the center of the sight glass. Check for leaks. The approximate capacity of the reservoir is 3 gallons (U.S.) or 12 liters. You will need a little more fluid to also fill the hoses and the seal cavity. Re-install the fill plug onto the reservoir.
8. Connect a pressure line to the mechanical seal lubricator pressure inlet port. Pressurize using a gas bottle, or other means. The required pressure is 25-50 psi (172-344 kPa) above the maximum vessel pressure, but not to exceed 145 psi (1 Mpa). The maximum vessel pressure is the process pressure plus the liquid head. Check all fittings for leaks.
9. Replace guarding on pedestal.

	Danger!
	Do not pressurize the vessel without having the mechanical seal lubrication system fully pressurized.

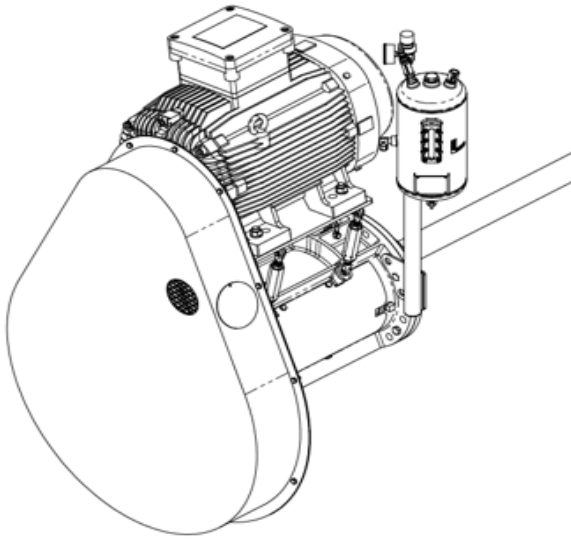

Lubrication System on Right Side

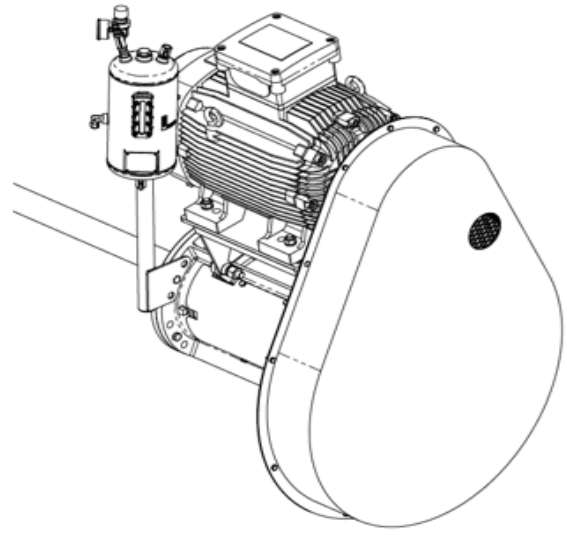

Lubrication System on Left Side

Figure 15: Double Mechanical Seal Reservoir



7 Operation

This SB Side Entry agitator has been designed with a modular construction with your specific application in mind. Following proper operating procedures will allow maximum mixer performance, and aid in the safe operation of your unit. Should problems arise, first review the manual's installation and troubleshooting sections. Please contact your local representative for any unresolved issues.

	Danger!
	Do Not operate the agitator before reading and following the instruction on all tags, decals, and nameplates attached to the equipment.
	Do Not operate the agitator in an empty tank or in a fluid with a specific gravity or viscosity higher than that for which it was designed.
	Do Not modify the agitator (i.e., motor horsepower, impeller, speed, etc.) without approval from NOV engineering.

7.1 Start-up Checklist

- Ensure that the agitator is correctly positioned (see certified location drawing) and that all fasteners are tightened to the recommended torque values.
- Check that the motor, starting and control device connections agree with wiring diagrams commonly found in motor conduit boxes and all applicable local codes.
- Ensure that the mechanical seal chamber has been vented for proper lubrication. For both single and double mechanical seals, trapped air must be removed from the system.
- Check that the lubrication and/or flushing supply to the double mechanical seal is operating correctly.
- Ensure that the motor is wired for the correct direction of impeller rotation.
- Ensure all guarding is in place and secured properly
- Double mechanical seal reservoir is filled with lubricant (double mechanical seals only)

7.2 Single Mechanical Seal Operation

The SB mixer is available with either a single or double mechanical seal cartridge assembly. In both cases this seal cartridge also houses the inboard bearing for the shaft system. The seal has been properly set and installed at the factory, and the bearing has been greased.

A single mechanical seal is lubricated by the process fluid. The seal must be vented prior to operation to release air that gets trapped in the seal cavity while the vessel is filled. The design also features a threaded leak detection port [54] for the mechanical seal. This leak port can be plumbed by the customer for a sight glass, a containment reservoir such as API Plan 65A/B, or a plug that will be removed for periodic inspection.

The seal cartridge is supplied with a butterfly valve at the top of the seal gland. Use this valve on single mechanical seals is to ensure that all trapped air is vented out of the mechanical seal chamber prior to starting the mixer. By necessity, this valve must be at the top of the seal for this purpose. After the tank has been filled past the height of the mixer, this valve should be opened until all air escapes from the seal cavity. Note that some tank contents will leak out along with the air. Wear proper personal protective equipment and have a containment method ready to collect product that comes out through this valve. If desired, additional plumbing can be added to the valve to capture the process fluid. Additionally, later this valve can also be used to check that the metal-to-metal shut-off has been correctly engaged, and the valve can be plumbed for flushing the shut-off area should the need arise. Any added plumbing must be easily removable so the single mechanical seal can be vented every time the liquid level drops below the mixer and then is raised up again.

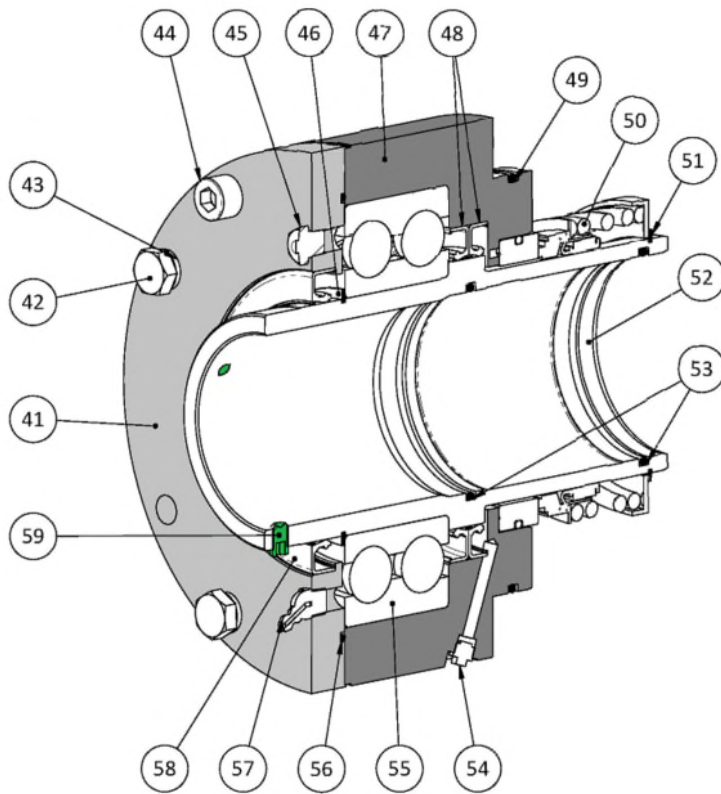

Figure 16: Mechanical Seal Assembly – Single

Table 8: Single Mechanical Seal Assembly		
Item No.	Description	Qty
41	Cover, Bearing	1
42	Hex Bolt	4
43	Lock Washer	4
44	Socket Head Cap Screw	2
45	Relief Fitting	1
46	Retaining Ring	1
47	Housing	1
48	Lip Seal	1 or 2
49	O-ring Seal	1
50	Single Mechanical Seal	1
51	Retaining Ring	1
52	Shaft Sleeve	1
53	O-ring Seal	2
54	Leak Detection Plug	1
55	Bearing	1
56	O-ring Seal	1
57	Grease Fitting	1
58	Lip Seal	1
59	Set Screw	3



7.3 Double Mechanical Seal Operation

The SB mixer is available with either a single or double mechanical seal cartridge assembly. In all cases this seal cartridge also houses the inboard bearing for the shaft system. The seal has been properly set and installed at the factory, and the bearing has been greased.

The double mechanical seal requires use of an external pressurized lubrication reservoir such as an API plan 53A or 53B seal system. See more details about this system in Section 7.5, Lubrication for Double Mechanical Seal Operation.

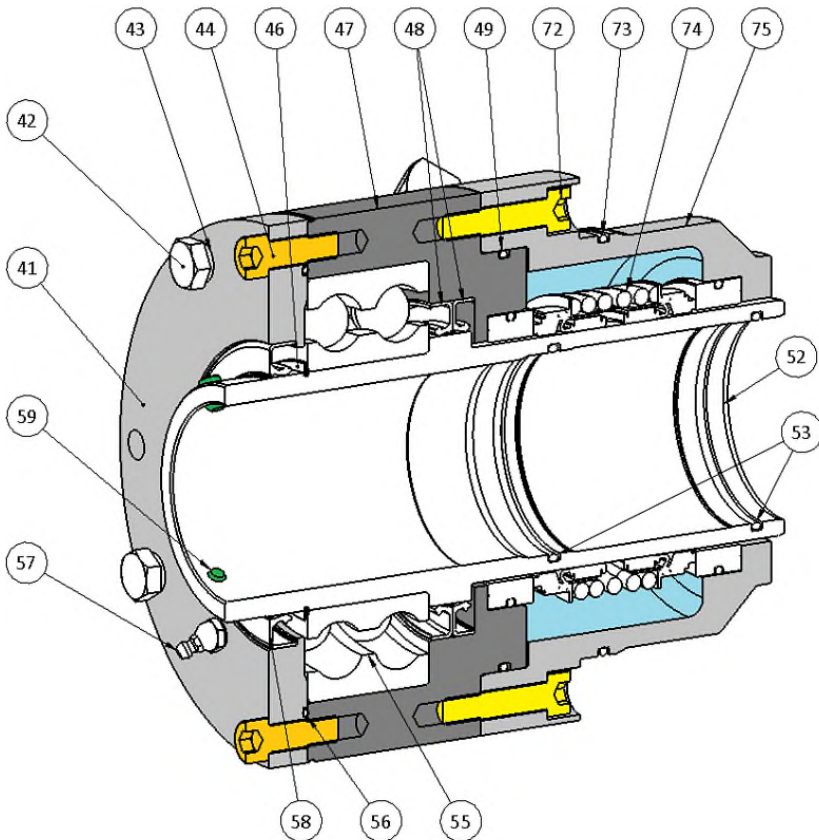

Figure 17: Mechanical Seal Assembly – Double

Table 9: Double Mechanical Seal Assembly		
Item No.	Description	Qty
41	Cover, Bearing	1
42	Hex Bolt	4
43	Lock Washer	4
44	Socket Head Cap Screw	2
45	Relief Fitting (See Figure 16)	1
46	Retaining Ring	1
47	Bearing Housing	1
48	Lip Seal	1 or 2
49	O-ring Seal	1
52	Shaft Sleeve	1
53	O-ring Seal	2
55	Bearing	1
56	O-ring Seal	1
57	Grease Fitting	1
58	Lip Seal	1
59	Set Screw	3
72	Socket Head Cap Screw	2
73	O-ring Seal	1
74	Double Mechanical Seal	2
75	Seal Housing	1
76	Outlet Fitting (See Figure 18)	1
77	Inlet Fitting (See Figure 18)	1

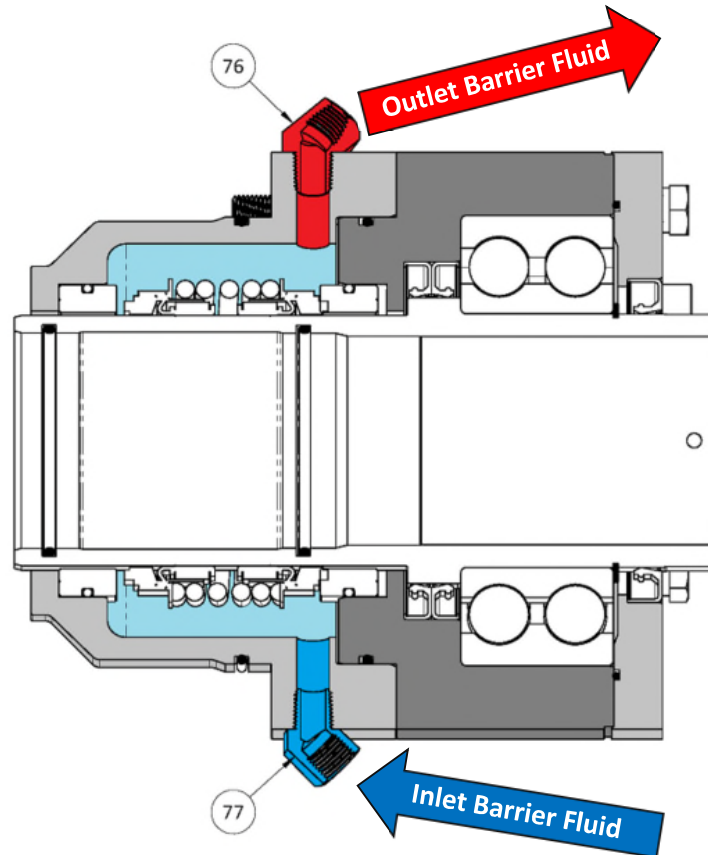

Figure 18: Mechanical Seal Assembly – Inlet & Outlet Plumbing

7.4 Optional Mechanical Seal Plumbing

The mechanical seals are shipped with a valve plumbed to a port on top of the seal gland. This valve can serve multiple purposes. On single mechanical seals, the valve is used to vent air trapped in the seal cavity prior to start up. For this reason, the valve must be at the top of the seal gland. This air is trapped during tank filling and must be vented prior to start up so the seal is fully lubricated by the process fluid. On both the single and double mechanical seals this valve provides a way to test if the metal to metal shut-off has fully engaged prior to seal maintenance.

On single mechanical seals, the seal cavity fills with process fluid because this fluid lubricates the mechanical seal. On double mechanical seals, the process fluid does not lubricate the seal, but there is a necessary cavity between the seal housing and the tank shut-off that will still fill with some process fluid. See Table 10 to see the amount of residual process fluid that will be trapped in each seal cavity.

Table 10: Residual Process Fluid Volume				
Case Size:	Single Mechanical Seal		Double Mechanical Seal	
	(fl. oz)	(mL)	(fl. oz)	(mL)
3SB	13.9	411	6.7	198
4SB	25.6	757	6.9	204
5SB	21.6	639	5.1	151



In some cases, debris can settle in the shut-off area and this can prevent the shut-off from fully engaging. A short flush is needed to push this debris out of the shut-off area. The provided valve on the top of the seal gland can be temporarily plumbed by the customer to act as a flush port to flush out any debris that may have settled in the shut-off area during operation. The flush should be between 10-15psi (69-103kpa) above the total fluid pressure in the tank. This should be easily removable plumbing, such as a quick disconnect fitting, so the valve can alternate between being used as a flush and then used again to verify the shut-off has engaged, and later used to vent the seal again on single mechanical seals.

If desired, a drain system can be plumbed to the leakage detection port that is plugged by NOV [54] to allow controlled draining of the trapped process fluid out of this cavity prior to removing the mechanical seal. Again, this drain is optional since it will be a relatively small amount of process fluid. Alternately, the customer could use this lower opening to plumb a more permanent flush system instead of using the upper valve as a drain and a flush.

7.5 Lubrication for Double Mechanical Seal Operation

A double mechanical seal must have a lubrication reservoir to supply a barrier fluid to the mechanical seal housing. See an example in **Figure 15**. The agitator must have either an NOV supplied mechanical seal lubricator, or a mechanical seal lubricator system supplied by others. A customer supplied system may be used provided it meets all the requirements of the application. For more details on the NOV supplied lubricator reservoir, see the supplemental manual at the end of this booklet.

The customer must supply a pressure regulated gas source to the fluid reservoir. The gas supply must be capable of maintaining a pressure of 25-50 psi (172-345 kpa) above the maximum pressure on the vessel side of the seal cartridge. This pressure includes the maximum combination of vessel operating pressure and the liquid head pressure.

Some leakage of the barrier fluid should be expected under normal operating conditions and is inherent with the design of mechanical seals. Leakage should be relatively low, around 1 or 2 drips per minute. Barrier fluid should always be chosen to be compatible with the process for this reason. Be sure to regularly inspect the fluid levels within the reservoir and top off as needed. Excessive reduction in barrier fluid level indicates a problem with the seal and/or lubrication system. Check all seal and reservoir connections and tighten or replace as necessary. If fluid levels continue to drop at an above average rate, then your seal may need replacing. Contact your NOV representative for further information. The condition of the barrier fluid should be inspected periodically. Failure to do so will have a negative impact on the lifespan of the seal. When maintaining or changing the seal, it is recommended to clean the lubrication system and replace the barrier fluid.

The seal lubricant can be any low viscosity fluid with reasonable lubricity that is compatible with the process fluid, and that is stable over the full range of pressures and temperatures at which the mechanical seal will be operated. Common liquid lubricants (barrier fluids) are shown in Table 11. Operating temperature limits for the lubricants are listed below. Consult your NOV representative for other lubricants.



Table 11: Mechanical Seal Lubricants		
Lubricant	Temperature Limits	
	°F	°C
Glycerin	≤ 150°	≤ 66°
Ethylene Glycol	≤ 250°	≤ 121°
Mineral Oil	≤ 400°	≤ 204°
Water	≤ 160°	≤ 71°

The specific gravity of any liquid lubricant should never be less than 0.63 at a reference temperature 50°F (28°C) above the maximum vessel temperature. The boiling (flash) point of a lubricant should never be less than 25°F (14°C) above maximum vessel operating temperature.

7.6 Troubleshooting

Table 12: Trouble-shooting Guide – Motors		
Observation	Possible Cause	Action
Motor will not start	Usually line trouble - single phasing at starter	Check source of power supply.
	Improper connection	Check connections with diagram.
	Load too heavy	Disconnect belt to see if it starts without load
Excessive hum	High voltage	Check input voltage
		Check connections
Regular clicking	Foreign matter in air gap	Take out rotor; remove matter
Rapid knocking	Bearing problem	See bearing guide
Motor overheating (Check with thermometer, don't depend on hand)	Overload	Measure load. Check for excessive friction in motor, drive, or machine. Potential process problem - contact your local NOV Mixing Technologies office. Do not reduce the load or replace motor with one of greater capacity without first consulting NOV Mixing Technologies.
	Single phase	Check current, all phases.
	Dirt in motor	Check air flow at ventilation ducts. Blow out motor. Use solvent on wound section if necessary.
	Unbalanced voltage	Check voltage, all phases.
	Rotor rubbing on stator	Check alignment. Clean air gap. Check and replace bearings, as necessary.
	Open stator windings	Disconnect motor from load. Check idle amps balance in all three phases. Check stator resistance in all three phases for balance.
	Open voltage	Check voltage.
	Grounding (short circuiting)	Locate with test lamp and repair.
	Improper connections	Recheck connections.



Table 13: Trouble-shooting Guide – Belts

Observation	Possible Cause	Action
Rapid belt wear	Worn sheave grooves	Inspect sheave grooves. Replace if necessary.
	Mismatched belts (for multiple belts designs only)	Replace with matched set.
	Belt slipping	Apply correct tension (use tensiometer).
	Improper installation	Replace belt(s) - install properly.
	Improper belt storage	Replace belt(s).
	Sheave misalignment	Realign sheaves.
	Shock loads from process	Contact NOV.
	Foreign object in drive	Clean out drive. Provide drive shroud.
Belt Turned Over	Broken cord in belt, due to improper installation	Replace belt(s); install properly.
	Impulse loads	Apply correct tension (use tensiometer).
	Misalignment of sheave and shaft	Realign drive.
	Worn sheave grooves	Replace sheaves.
	Loose belt(s)	Tighten belt(s).
	Excessive belt vibration	Check Alignment Check equipment for solid mounting.
Belt slipping	Insufficient tension	Apply correct tension (use tensiometer).
	Worn sheave grooves	Inspect sheave grooves. Replace if necessary.
Belt Squealing	Insufficient tension	Apply correct tension (use tensiometer).
	Belt bottoming grooves	Replace sheave and/or belt(s).
	Heavy starting load	Investigate load source and contact NOV Mixing Technologies.
Checked or cracked belt(s)	Excessive heat due to slippage	Replace belt and apply correct tension.
	Excessive ambient temperature	Improve ventilation.
Mismatched belts (for multiple belt designs only)	Sheave grooves worn unevenly; Improper groove angle. Give appearance of mismatched belts	Replace sheaves and belt(s) and align.
	Sheave shafts not parallel. Give appearance of mismatched belts.	Align drive.
Hot Bearings	Excessive tension	Apply correct tension (use tensiometer).
	Excessive heat due to slippage	See belt slippage

Table 14: Trouble-shooting Guide – Bearings

Observation	Possible Cause	Action
Overheating Bearing	Wrong type of grease or oil causing break-down of lubricant	Consult reliable lubricant manufacturer for proper type of lubricant.
	Inadequate amount of lubricant.	Consult IOM for proper amount of lubricant.
	Excessive amount of lubricant.	Clean and repack bearing with correct amount of lubricant per IOM.
	Housing bore too large.	Replace housing with one having proper size.
	Incorrect linear or angular alignment of shafts	Be sure that shafts are coupled in a straight line.
Hard turning of shaft	Wrong type of grease or oil causing break-down of lubricant.	Consult reliable lubricant manufacturer for proper type of lubricant.
	Inadequate amount of lubricant.	Consult IOM for proper amount of lubricant.
	Excessive amount of lubricant	Check and repack with correct amount of lubricant.
	Excessive distortion of housing.	Check if foundation settled under pedestal support. Verify shims or studs were used to level mixer. Verify tie rod tension.
	Poor shaft alignment	Loosen split coupling bolts and re-align drive shaft in outboard bearing with extension shaft in seal.
	Foreign matter in housing.	Clean out bearing housing. Replace worn-out seals to obtain adequate protection of bearings.
	Corrosive agents entering the bearing housing.	Addition of a shroud or flinger to throw off foreign matter.



Table 15: Trouble-shooting Guide – Bearings (cont'd)

Observation	Possible Cause	Action
Noisy Bearing	Wrong type of grease or oil causing break-down of lubricant	Consult reliable lubricant manufacturer for proper type of lubricant.
	Insufficient amount of lubricant	Consult IOM for proper amount of lubricant.
	Foreign matter in housing	Clean out housing. Replace worn-out seals to obtain adequate protection of bearings.
	Corrosive agents entering the bearing housing	Addition of a shroud or flinger to throw off foreign matter.
	Excessive distortion of housing.	Check if foundation settled under pedestal support. Verify shims or studs were used to level mixer. Verify tie rod tension.
	Poor shaft alignment	Loosen split coupling bolts and re-align drive shaft in outboard bearing with extension shaft in seal.
	Flat on roller due to skidding (result of fast starting)	Carefully examine rollers, looking for flat spots on the surface. Replace bearing.
	Incorrect method of mounting, hammer blows on bearing	Replace with new bearing. Never hammer any part of bearing when mounting.
	Distorted shaft and other parts of bearing assembly	Only in extreme case should a blow torch be used to facilitate removal of a failed bearing. Care should be exercised to avoid high heat concentration at any one point, so distortion is eliminated. Replace distorted parts.
	Bearing exposed to vibration while machine is idle	Carefully examine bearing for wear spots separated by distance equal to the spacing of the balls or rollers. Replace bearing.
	Unbalanced load.	Rebalance unit.



Table 16: Trouble-shooting Guide – Bearings (cont'd)

Observation	Possible Cause	Action
Vibration	Foreign matter entering housing	Clean out bearing housing. Replace worn-out seals to obtain adequate protection of bearing.
	Corrosive agents entering the bearing housing	Addition of a shroud or flinger to throw off foreign matter.
	Excessive distortion of housing.	Check if foundation settled under pedestal support. Verify shims or studs were used to level mixer. Verify tie rod tension.
	Poor shaft alignment	Loosen split coupling bolts and re-align drive shaft in outboard bearing with extension shaft in seal.
	Flat on roller due to skidding (result of fast starting)	Carefully examine rollers, looking for flat spots on the surface. Replace bearing.
	Incorrect method of mounting. Hammer blows on bearing.	Replace with new bearing. Never hammer any part of bearing when mounting.
	Excessive clearance in bearing, resulting in vibration	Use bearings with recommended internal clearances. Replace worn bearings.
	Vibration of machine	Check balance of rotating parts.
	Inadequate support in housing	Re-shim pedestal support or adjust tie rods to align machine and obtain proper support.



8 Maintenance

8.1 Motor Lubrication

The motor bearings are properly greased by the manufacturer. Motor bearings should be re-greased at 12-month intervals when installed in clean, dry environments, or every six months for heavy duty and dusty locations. Any good quality general-purpose grease consisting of a refined base oil stock and a lithium, calcium, or polyurea (preferred) complex-based soap, with an NLGI No. 2 classification, will work satisfactorily. Most major oil companies offer such products, usually with extreme pressure (EP) additives for additional protection. **Different greases are not always compatible. Check for compatibility of greases before you replace one with another.**

When re-greasing, stop the motor, remove the outlet plug and add grease according to motor supplier's recommendations with a hand lever gun only. Run the motor for about ten minutes before replacing the outlet plug. Certain TEFC motors have a spring relief outlet fitting on the fan end. If the outlet plug is not accessible at the surface of the hood, it is the spring relief type and need not be removed when re-greasing.

	Danger!
	<i>Over-greasing is a major cause of bearing and motor failure.</i>

The following actions can be taken to correct or prevent motor over-greasing and related problems¹:

1. Review motor lubrication procedures to ensure that they identify the type and quantity of grease to use, the specific fill and drain nozzles to uncap, and the length of time motors should be run with drain plugs off after greasing the bearings.
2. To prevent foreign materials from contaminating the grease, ensure that grease containers are covered during periods of storage and that the nozzles and grease fittings are cleaned.
3. Determine the optimum quantity and correct type of grease required for each motor by examining the manufacturer's recommendations and by monitoring the behavior of grease added to motors.
4. Consider using pre-lubricated sealed bearings in applications where re-lubrication is difficult, where contaminants can adulterate the grease, or where over-greasing might damage safety systems.

¹US Nuclear Regulatory Commission, Information Notice No. [88-12](#)

8.2 Drive Bearing Lubrication

Both the outboard bearing and the inboard bearing are grease lubricated. These bearings are packed with grease prior to shipment from the factory. At 6-month intervals under continuous use these bearings should be re-greased. Adjust the time between re-greasing accordingly if the mixers are not running at least 8 hours a day every day. Do not go more than 12 months regardless of the amount of time the mixer has run without re-greasing. Use the amounts shown in Table 18 for re-greasing a bearing that has previously been greased. Use Table 17 for a new bearing that has not been greased.



Always rotate the bearings by hand while re-greasing to evenly distribute the grease throughout the bearing. Grease can be injected into the outboard bearing housing and the mechanical seals housing grease fittings by accessing them through the pedestal opening. There are 1/4-inch N.P.T. fittings on both housings inside the pedestals or plumbed just outside of the hand hold covers. It is recommended that the agitator be shut down when greasing to avoid accidental contact with the rotating shaft. The mixer shaft can be rotated by hand to distribute the grease after the motor power is turned off.

Always use the same type of grease previously used in the bearing. Some greases lose lubricating capability when mixed with another grease. Never mix greases with unlike bases without first checking compatibility with the supplier. Any good quality general-purpose grease consisting of a refined base oil stock and a lithium, calcium, or polyurea (preferred) complex-based soap, with an NLGI No. 2 classification, will work satisfactorily. Most major oil companies offer such products, usually with extreme pressure (EP) additives for additional protection.

Table 17: Recommended Initial Grease Volumes				
Case Size:	Seal Bearing		Outboard Bearing	
	(oz)	(gm)	(oz)	(gm)
3SB	2.2	63.3	6.7	190.7
4SB	4.0	112.5	10.6	300.1
5SB	6.4	182.6	12.9	366.9

Table 18: Recommended Replenishment Grease Volumes				
Case Size:	Seal Bearing		Outboard Bearing	
	(oz)	(gm)	(oz)	(gm)
3SB	0.8	22.9	0.7	20.2
4SB	1.1	31.1	0.9	26.3
5SB	1.5	41.9	1.2	33.2

8.3 Seal Replacement

8.3.1 Tank Shut-Off System

The SB mixer includes an integral tank shut-off feature which allows the operator to service the mechanical seal and bearings under full tank conditions. The metal to metal seal isolates the tank contents from the mixer’s seal housing. A secondary O-ring seal is also included for redundancy purposes to ensure tank isolation is maintained. Tank isolation can be verified prior to seal removal by using the vent valve [61].

	Note!
	There will always be some residual process fluid trapped outside of the shut-off in the seal cavity. See Table 10 for the volume of this trapped product.

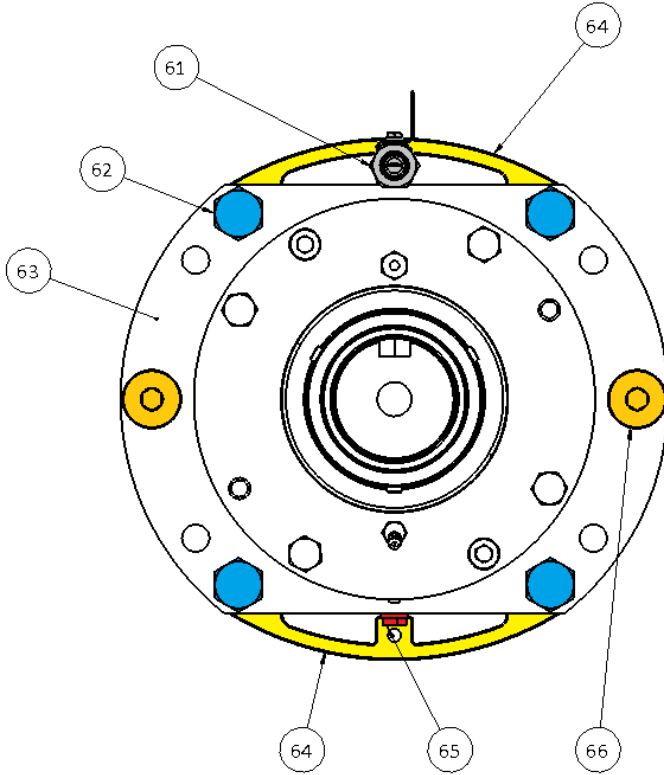

Table 19: Tank Shut-off System		
Item No.	Description	Qty
61	Leak Detection Valve/Vent	1
62	Clamping Bolt	4
63	Seal Gland	1
64	Spacer	2
65	Seal Cavity Plug	1
66	Socket Head Shoulder Bolt	2

Figure 19: Tank Shut-off System

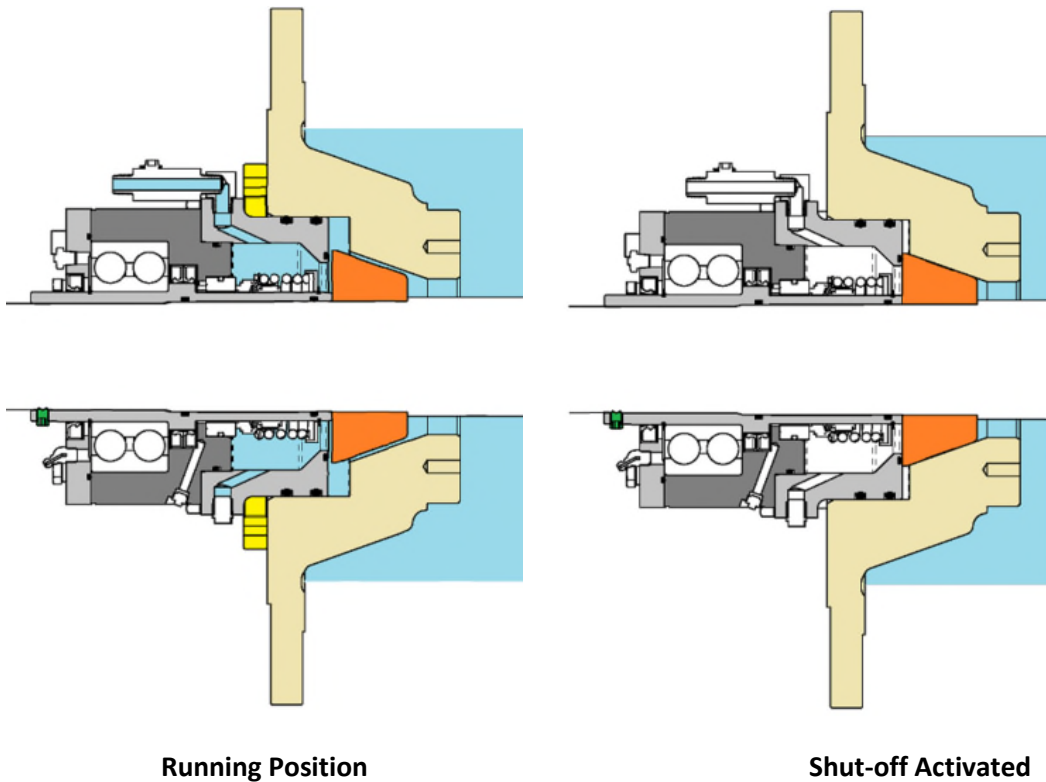



Figure 20: Tank Shut-off System



8.3.2 Steps to Engage Tank Shut-off System for Double Shaft Mixers

1. Turn off the agitator. Lock out all electrical connections so the mixer cannot be energized.
2. Depressurize the vessel.
3. Remove the pedestal side guards to access the seal.
4. Double Mechanical Seal Only: Depressurize the seal lubrication system lines, disconnect the hoses and plug the ports.

	Danger!
	<i>The seal lubricant may be hot. Allow the seal system to cool down prior to disconnecting the hoses.</i>

5. Rotate the shaft by hand so that the split coupling bolts are easily accessible with a wrench. Once the shut-off is engaged the shaft cannot be turned to give better tool access.
6. Loosen but do not remove the (4) split coupling bolts **[80 (Figure 21)]** closest to the mechanical seal to loosen the grip on the mixer shaft just enough to allow the shaft to slide in the coupling in a later step.
7. Remove the four (4) large hex head bolts **[62 (Figure 19)]** from the seal gland **[63]** and thread them into the threaded jacking holes directly next to where they were previously installed in the gland. **DO NOT** loosen or remove the socket head shoulder bolts **[66]**. They will remain in place the entire time.
8. Using a hand wrench, slowly tighten the hex head bolts **[62]** that were just moved to the jacking holes one at a time to push the seal away from the flange. Push the seal off evenly and slowly to avoid binding. Only push the seal back enough to allow the two (2) seal spacers **[64]** to be removed; around 0.13" [3mm]. There is an M8 tapped hole in the middle of the spacers to aid in retrieving them if needed.
9. Once the spacers are removed, return the four (4) hex head bolts **[62]** to the thru holes in the gland **[63]** and thread the bolts into the flange. Tighten the hex head bolts until they are difficult to tighten any more. The shaft and seal should move approximately 0.25" [6mm] axially into the flange. Once the bolts are tight this means the shut-off collar **[83]** has seated into the flange. **Do not** fully torque the hex head bolts **[62]** yet.
10. Loosen the four (4) smaller hex head bolts **[42 (Figure 16 or Figure 17)]** on the bearing cover **[41]** approximately 0.25" [6mm].
11. Further tighten the four (4) large hex head bolts **[62]** on the seal gland. The gland **[63]** should now move a further 0.13" [3mm] to fully engage the shut-off **[83]** while the seal stays in place on the shaft. There should be about a 0.13" [3mm] gap between the seal and the gland now.
12. Test to see if the shut-off has fully engaged by opening the valve **[61]**. There will be a small amount of leakage from residual tank contents in the valve plumbing even when the shut-off is fully engaged. If leakage continues, then the shut-off has not properly engaged. There may be debris that has settled in the seal area that is preventing the metal to metal shut-off from fully closing, or perhaps the bolts **[62]** were not tightened enough. More torque can be applied to the hex head bolts **[62]** to try to crush the debris and to fully seal the shut-off. If that does not work, then a process compatible flushing fluid should be pushed through the leakage indicator valve **[61]** to flush out the shut-off area. See Section 7.4 on page 25 for more information on the optional flush system. Back up the seal a small amount prior to activating

the flush to allow room for trapped debris to leave, and to generate flow. To back the seal off, reverse the steps 9 through 11. After running the flush for a short time, turn off the flush and disconnect it from the valve. Follow steps 9 through 11 again and retest the shut-off. Do not proceed to the next step until the shut-off has been verified.

13. Loosen the three set screws on the seal sleeve [59 (Figure 16 or Figure 17)].
14. Remove all eight (8) socket head bolts [80] on the split coupling [5] and remove the coupling [5] and keys [81].

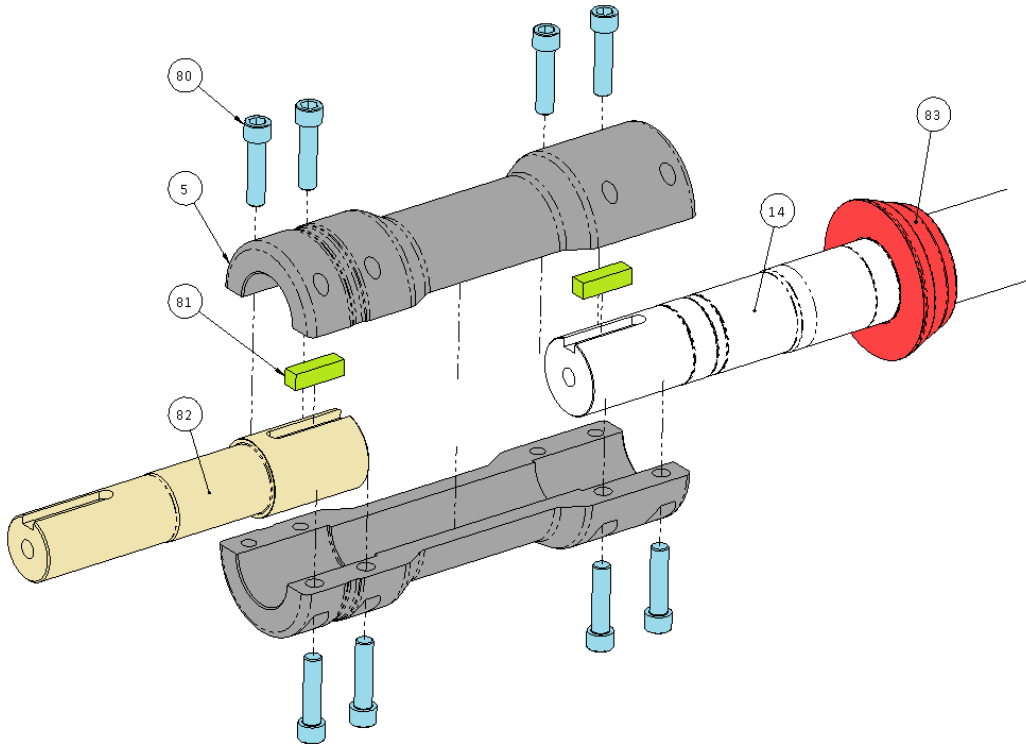



Figure 21: Shaft Coupling Assembly

15. Clean the agitator shaft [14] and fix any scratches outside of the mechanical seal so the seal can slide easily on the shaft when it is time. Grease can be applied to the shaft to make sliding the seal easier, especially on the largest shaft diameter closest to the seal.
16. Fully remove the four (4) smaller hex head bolts [42] on the seal cap [41]. Remove the two plastic plugs on the seal cover [41] and insert two of the hex head bolts [42] into these holes that were plugged and thread them in by hand.
17. Turn the two smaller hex head bolts [42] that were inserted into the holes to slowly push the seal out of the seal gland [63]. The seal can now slide by hand along the shaft and be removed from the pedestal.



8.3.3 Steps to Engage Tank Shut-off System for Single Shaft Mixers

The tank shut-off system for the single shaft mixers is identical in the seal area, but the seal removal process is more involved due to the outboard bearing needing to be removed.

	Danger!
	<i>Some of the large sheaves are very heavy. The outboard bearing housing is also heavy. Extra lifting equipment may be necessary to safely remove these components prior to removing the seal.</i>

1. Turn off the agitator. Lock out all electrical connections so the mixer cannot be energized.
2. Depressurize the vessel.
3. Remove the pedestal side guards to access the seal.
4. Double Mechanical Seal Only: Depressurize the seal lubrication system lines, disconnect and plug the ports.

	Danger!
	<i>The seal lubricant may be hot. Allow the seal system to cool down prior to disconnecting the hoses.</i>

5. Remove the outer belt guard cover **[4A]**.
6. Loosen the hex bolt and nut on the motor bracket **[18, 19]**. Loosen the hex jam nuts **[16]** on the turnbuckles **[17]** on the motor bracket and then loosen the tension on the belt **[2]** by turning the turnbuckles until the belt **[2]** can be slipped off the motor sheave **[1B]**. Remove the belt.
7. Remove the large and small sheaves **[1B, 3B]**. See Sections 8.10.3 on page 46 and Section 8.10.4 on page 46 for instructions on how to do this.
8. Loosen the three set screws on the outboard bearing housing sleeve **[93]**.
9. Follow steps 7 through 13 in Section 8.3.2 to fully engage the shut-off.
10. Remove the remaining portion of the belt guard from the bearing housing **[4]**.
11. Carefully remove the nuts **[97]** that fasten the bearing housing **[105]** to the pedestal **[6]**. Leave the studs **[99]** in the pedestal. Remove the complete bearing housing **[105]** carefully; the bearing assembly is heavy.
12. Clean the agitator shaft **[14]** and fix any scratches outside of the mechanical seal so the seal can slide easily on the shaft. Grease can be applied to the shaft to make sliding the seal easier, especially on the larger shaft diameter closest to the seal.
13. Fully remove the four (4) smaller hex head bolts **[42]** on the seal cap **[41]**. Remove the two plastic plugs on the seal cover **[41]** and insert two of the hex head bolts **[42]** into these holes that were plugged and thread them in by hand.
14. Turn the two smaller hex head bolts **[42]** that were inserted into the holes to slowly push the seal out of the seal gland **[63]**. The seal can now slide by hand along the shaft and be removed from the pedestal.



8.4 Mechanical Seal Disassembly

When the mechanical seal cartridge is disassembled, the bearing [55], lip seals [48, 58] and O-rings [49, 53, 56, 73] should be replaced. Order replacement parts from NOV or obtain full manufacturer's data from NOV before ordering. Prepare a clean work area prior to disassembly/assembly of the mechanical seal cartridge. To service the seal, the seal sleeve and bearing will need to be pressed out of the seal housing with a hydraulic press. No other special tooling is necessary. The instructions for disassembling the single and double mechanical seals are nearly identical.

1. Turn the seal so that the outer cap [41] is facing down on the table and the seal side [50 or 74] is up in the air.
2. *For the double mechanical seal only*, loosen the two socket head cap screws [72] and remove the outer seal housing [75]. Press the stationary seal component out of the outer seal housing your fingers or a soft tool to press on the seal in the cutouts in the back of the housing.
3. *For the single mechanical seal only*, carefully remove the retaining ring [51] on the end of the seal sleeve [52] to release the spring pressure on the seal. Be careful, the spring will expand rapidly once the snap ring is removed. Remove the loose seal components.
4. For both types of seals, clean off the outside of the seal sleeve [52] above the remaining seal components so they can slide up the sleeve as easily as possible. It will help to use a lubricant on the shaft such as soapy water or a compatible lubricant to make it slide easier. If the seal will not come off because of trapped debris or corrosion, it can be removed at the same time as the bearing is pressed out of the housing, but this will likely damage the seal beyond reuse.
5. Remove the seal components by pulling them off the sleeve with your hands. Use of hard tools for this may damaging the seal and sleeve. *For the double mechanical seal only*, remove the inboard seal, then remove the loose spring and other seal piece, and again clean off the exposed seal sleeve [52] as much as possible so the outboard seal pieces can slide up the sleeve.
6. Turn the seal over so the cap [41] is facing up. Remove the set screws [59] from the sleeve [52].
7. Remove the two socket head screws [44] and then remove the cap [41]. Remove the lip seal [58] from the cap.
8. Remove the retention ring [46] from the seal sleeve [52] on top of the bearing [55].
9. With the seal housing [47] upside down such that the bearing [55] is facing down and the sleeve [52] where the seals were installed is facing up, use a mechanical or hydraulic press to push down carefully on the end of the sleeve [52] to push the bearing [55] out of the housing [47]. Have a safe means to catch the sleeve and bearing so they are not damaged once they are pushed clear of the housing.
10. Remove the stationary portion of the seal that is retained in the bearing housing [47]. The housing has two reliefs cut in the back of the seal to provide an area to push against the seal. Also remove the lip seal(s) [48] in the bearing housing.
11. Press the seal sleeve [52] off the bearing [55], again being careful not to damage the seal sleeve as it releases from the bearing.
12. Remove remaining O-rings [49, 53, 56, 73] from all components and inspect all items for damage.



8.5 Mechanical Seal Assembly

Make sure that the seal assembly is done in a clean area. Completely clean all parts that will be reused and inspect for damage. It is recommended to use all new fasteners. The instructions for assembling the single and double mechanical seals are nearly identical.

1. Press the bearing sleeve [52] into the bearing [55], being careful to support both the inner and outer rings of the bearing to avoid damaging the bearing. Insert the retaining ring [46] onto the sleeve [52] above the bearing [55].
2. Press the lip seal(s) [48] into the bearing housing [47]. It is critical that the seals are installed in the correct orientation as shown in the seal assembly drawing or the figures provided in this IOM. Grease the inside diameter of the lip seals with the same grease you intend to use for the bearing.
3. Press the bearing and sleeve assembly into the bearing housing [47] being careful that the sleeve [52] passes easily past the lip seal(s) [48].
4. Insert the lip seal [58] into the bearing cap [41]. Also install the O-ring [56] in the cap [41] using a small amount of grease to keep the O-ring in place.
5. Install the cap [41] onto the bearing housing [47] being sure the O-ring [56] stayed in place. Insert and torque the two socket head cap screws [44] to the values shown in the Appendix, page 50.
6. Reinstall the plastic plugs over the jacking screw holes in the cap.
7. Carefully insert the stationary seal seat into the bearing housing [47] by hand; use of tools to install the seal could cause damage. Apply a small amount of soapy water if needed to ease the installation of the seal into the housing. Be careful to keep the sealing face clean. If there was an anti-rotation pin present originally in the housing, retain that pin and re-use it. If a new one is needed, use a short piece of 1/8" [3mm] 316SS or C276 weld wire. When an anti-rotation pin is present, be sure to align the anti-rotation slot machined in the bottom of the seal with the pin to avoid damaging the pin and seal. *For the double mechanical seal only*, also install the stationary seal seat into the seal housing [75], along with the anti-rotation pin if needed, following the same instructions above.
8. Carefully install the rotary seal elements over the shaft sleeve [52]. A small amount of lubricant such as water mixed with a small amount of dish soap or a compatible light lubricant can be applied to make assembly easier. Install the seal to the seal setting height recommended by the seal supplier as measured from the top of the stationary seal face. After the seal is at the correct height, then install the spring and other loose seal components.
9. *For the double mechanical seal only*, after installing the outboard seal closest the bearing, next install the inboard rotary seal components onto the sleeve. To set the seal height on the inboard seal, measure from the outboard seal already installed to the central "V" groove in the sleeve. Set the second seal to that same distance on the other side of the central groove. Install the seal housing [75] over the seal and install and torque the two socket head cap screws [72] to the values in the Appendix, page 50.
10. *For the single mechanical seal only*, carefully install the snap ring [51] onto the end of the seal sleeve [52] to set the seal spring.
11. Install the two O-rings [53] into the inside of the seal sleeve [52].



12. Retain the seal set screws [59], but they do not need to be installed into the sleeve until the seal has been installed onto the mixer shaft to avoid accidental shaft damage. They will later be installed with blue Loctite® 242 or similar liquid thread locker prior to fully torquing the screws onto the shaft.
13. Add grease to bearing. Remove the grease relief fitting [45] from the cap if it is already installed. Fill with grease slowly using the grease fitting [57] while occasionally spinning the bearing to evenly distribute the grease throughout the bearing cavity. Refer to section 8.2 on page 32 for more information on grease selection and volume. Once filled to the correct volume, install the relief fitting [45].
14. *For the double mechanical seal only*, to test the seal cartridge at 100 psi (690 kpa) or less, fill the seal housing with a fluid that is compatible with the process. This is normally the seal lubricant. Pressurize the mechanical seal housing to the lowest of either 50 psi (345 kpa) above the maximum vessel operating pressure, or 100 psi (690 kpa). Do not test above 100 psi (690 kpa) without consulting NOV as special flanges will be necessary. Check for leaks and correct as required. If the mechanical seal cartridge is to be placed into inventory, the seal housing should be completely filled with a rust preventative or lubricant which is compatible with the sealing fluid to be used in service. Plug the seal fluid ports. If testing the seal with air, do not test above 25psi (173 kpa).

8.6 Disassembling the Outboard Bearing Assembly

It is recommended to rebuild the outboard bearing at the same time you are also going to service the mechanical seal since many of the same steps must be followed to engage the shut-off for the tank so the shaft is supported while the outboard bearing is removed. You cannot remove the outboard bearing without engaging the shut-off.

1. No matter if you have a single or a double shafted unit, to remove the outboard bearing assembly, follow the instructions to engage the shut-off up through step 11 in Sections 8.3.2, starting on page 35. Once the outboard bearing assembly is removed, move it to a clean work area for further disassembly.
2. Remove the three set screws [93] from the shaft sleeve [94].
3. Remove the four (4) hex head bolts [90], then remove the cap [91]. Remove the lip seal [95] from the cap [91].
4. The bearing [98] should slide easily out of the housing [105] along with the shaft sleeve [94]. Remove the lip seal [102] from the housing.
5. Remove the tapered snap ring [92] from the shaft sleeve [94], and then press the bearing [98] off the sleeve [94] using a mechanical or hydraulic press. Be careful to remove the sleeve carefully to avoid damaging the sleeve in the press or when it falls out of the bearing.

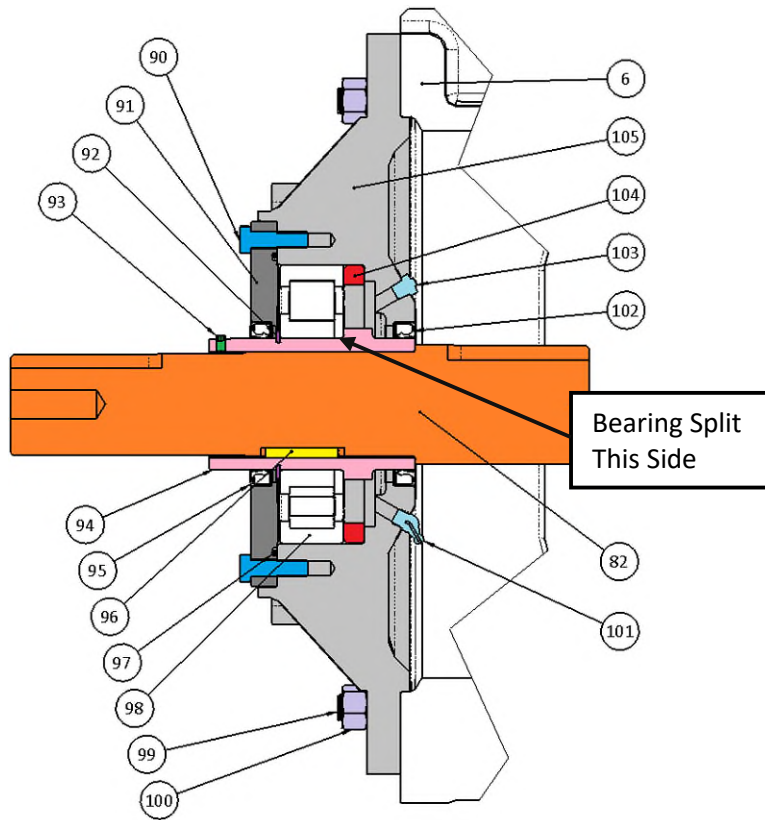

Figure 22: Outboard Bearing Assembly

Table 18: Outboard Bearing Assembly		
Item No.	Description	Qty
6	Pedestal	1
82	Outboard Drive Shaft	1
90	Hex Bolt	4
91	Bearing Cap	1
92	Tapered Snap Ring	1
93	Set Screw	3
94	Shaft Sleeve	1
95	Lip Seal	1
96	Key	1
97	O-ring	1
98	Bearing	1
99	Stud	8
100	Hex Nut	8
101	Grease Fitting	1
102	Lip Seal	1
103	Grease Relief Fitting	1
104	Spacer (2-piece shaft only)	1
105	Bearing Housing	1

8.7 Assembling the Outboard Bearing Assembly

1. Install a new lip seal [95, 102] into the bearing housing [105] and into the bearing cap [91].
2. Slide the split bearing ring from the bearing [98] onto the sleeve [91], making sure that the side of the bearing ring with the radius is all the way against the radius corner of the sleeve shoulder. Press the new cylindrical bearing [98] onto the sleeve [94] until the split ring is firm against the shoulder. If the bearing was installed correctly, a shim should not be fit between the bearing ring and the shoulder. Be careful not to stress the bearing rollers when installing the bearing. Press only on the inner race of the bearing, not the outer race.
3. Insert the tapered snap ring [92] onto the sleeve [94] with the chamfered side of the ring facing away from the bearing.
4. *Double shaft unit only*, ensure the bearing spacer ring [104] is installed in the housing before inserting the bearing.
5. Grease the lip seal [102] installed in the housing [105], then insert the bearing/sleeve assembly into the housing. The bearing [98] should slide into the housing [105] with only a slight tap of a soft mallet.
6. Install the O-ring [97] into the bearing cap [91] with a small amount of grease to keep it in the cap, then install the cap [91] onto the housing [105]. Fully torque the four (4) hex head bolts [90] to the values in the Appendix, page 50.



7. Add grease to the assembly. Remove the grease relief fitting **[103]**. Fill the grease fitting **[101]** with grease slowly while occasionally spinning the bearing to evenly distribute the grease throughout the bearing cavity. Refer to section 8.2 on page 32 for more information on grease selection and volume. Once filled, install the relief fitting **[103]**.
8. Retain the three (3) set screws **[93]** for use later once the shaft is inserted into the sleeve **[94]**. At that time the set screws **[93]** will be inserted with a small amount of blue Loctite® 242 or similar and torqued.

8.8 Installing the Outboard Bearing Assembly

1. Ensure all the mounting studs **[99]** are installed into the pedestal **[6]** such that they are flush with the back side of the pedestal casting. Check for damaged threads and replace as necessary.
2. *For the single shaft unit only*, ensure the key **[96]** for the bearing sleeve **[94]** has been installed in the shaft keyway. Use some adhesive if needed to keep the key in the keyway for installation.
3. Carefully lift and install the bearing housing **[105]** onto the pedestal **[6]** being careful not to bend or damage the studs **[99]** while installing. Ensure that the housing is oriented such that the grease relief fitting **[103]** is at the top.
4. Install the nuts for the outboard bearing assembly **[100]** and fully torque to the values in the Appendix, page 50.
5. Re-install the belt guard plate **[4]** onto the housing **[105]**, fully torquing the hex head bolts to the values in the Appendix, page 50.
6. *For the double shaft units only*, install the drive shaft **[82]** with the bearing sleeve key **[96]** into the bearing sleeve **[94]**. Install the three set screws **[93]** into the sleeve **[94]** using a small amount of blue Loctite® 242 or similar to help retain the screws. Torque the set screws to the values shown in the Appendix, page 50.
7. *For the single shaft units only*, do not install the bearing sleeve set screws **[93]** at this time. These should not be installed until the seal shut-off has been fully disengaged.

8.9 Mechanical Seal Installation



Note!

Prior to installation of a new or rebuilt mechanical seal cartridge, inspect the drive shaft **[82]**, coupling halves **[5]**, extension shaft **[14]** and keys **[81]** for fit and finish. All mating surfaces must be clean and free from burrs and nicks.

1. Inspect the seal cartridge mounting area of the extension shaft **[14]** for wear and/or damage. Clean the drive shaft and polish out any scratches. Pay special attention to the area where the set screws dug into the shaft previously. Clean and inspect the seal gland **[63]** and mounting flange **[8]** prior to installation. Again, clean up any scratches or damage.
2. Coat the drive shaft **[14]** with a lubricant which is compatible with the process and seal elastomers.



3. Slide the new or rebuilt seal cartridge onto the shaft [14] and push the seal until the seal sleeve end [52] contacts the back of the shut-off collar [83]. Watch that your fingers are not behind the seal while pushing. If the seal will not slide on all the way, you may need to use the seal bolts [42] to draw the seal in the last 0.50" [12mm]. Note that the seal will not sit all the way against the gland plate [63]. There should be a 0.13" [3mm] gap between the seal and the gland once the seal contacts the shut-off collar [83]. This gap will be closed later as we dis-engage the shut-off.
4. Install the three seal set screws [59] into the seal sleeve [52] with a small amount of blue Loctite® 242 or similar. Torque the set screws to the values shown in the Appendix, page 50.
5. Align the seal with the seal gland [63] so that the long seal bolts [42] can be threaded into the seal gland [63]. Tighten the four (4) bolts [42] to around 25% of the full torque, or "hand tight". These will be fully torqued later.
6. *For the double shaft units only*, install the split coupling on the shafts [14, 82], but do not fully torque the socket head bolts [80] in the coupling. Match the groove turned on one half of the coupling to make sure the set is in the correct orientation. Torque the bolts [80] to around 25% of the full torque value.
7. *For the single shaft units only*, install the outboard bearing assembly per Section 8.8, page 42. Do not install the set screws [93] into the outboard bearing sleeve [94] at this time.
8. Ensure that the valve [61] on the mechanical seal is in the "off" position to avoid accidental leakage once the shut-off is disengaged.
9. Remove the four large hex head bolts [62] in the seal gland [63]. **Do not** remove the two (2) socket head shoulder bolts [66]. Move the large hex head bolts [62] to the jacking screw holes next to where the bolts were previously installed in the gland.
10. Slowly push the seal gland [63] back just enough for the two gland spacers [64] to slide behind the seal gland [63]. Move the gland back slowly and evenly by tightening each bolt [62] a little at a time using a star pattern to ensure the gland moves back evenly on all sides. If you drive it in too fast with one bolt, the gland may bind in the flange.
11. Once the spacers [64] can fit behind the seal, remove the large hex bolts [62] from the jacking holes and replace them in the thru holes in the seal gland [63], making sure that the bolts go through the holes in the seal spacers [64]. Using a star pattern again, tighten the large hex head bolts [62] in the gland [63] until the gland is fully seated against the spacers. Torque the bolts to the values shown in the Appendix, page 50.
12. Tighten the four smaller hex head bolts [42] on the seal cover [41] to completely seat the seal onto the seal gland [63]. Fully torque the hex bolts [42] to the values shown in the Appendix, page 50. There should no longer be any gap between the seal and the gland.
13. *For single mechanical seals*, if the tank liquid level is above the mixer seal, release the vent valve [61] to vent out trapped air until only process fluid comes out of the valve. Close the valve [61] and continue.
14. *For the double shaft mixers only*, slide the split coupling [80] so it is approximately equally spaced on the two shafts. Tighten the coupling bolts making sure the gaps on both sides of the coupling are the same. Torque the socket head cap screws to the values shown in the Appendix, page 50.
15. *For the single shaft mixers only*, slide the outboard bearing sleeve [94] until it sits against the shoulder of the shaft inside the pedestal. Now install the three (3) outboard bearing sleeve set screws [93] with a



small amount of blue Loctite® 242 or similar. Torque the set screws to the values shown in the Appendix, page 50.

16. *For double mechanical seals only*, replace the lubrication lines on the seal, fill the lubrication reservoir, and bleed off extra air out of the system, per the instructions in Section 6.5 on page 20.
17. *For the single shaft mixers only*, reinstall and tension the belt and reinstall the belt guards per Section 6.3 on page 14.
18. Rotate the mixer shaft by hand a few rotations to feel for any binding or listen for any unusual noises. If there is anything unusual stop and consult the Troubleshooting guide in Section 7.6 on page 27.
19. Replace the guards on the pedestal.

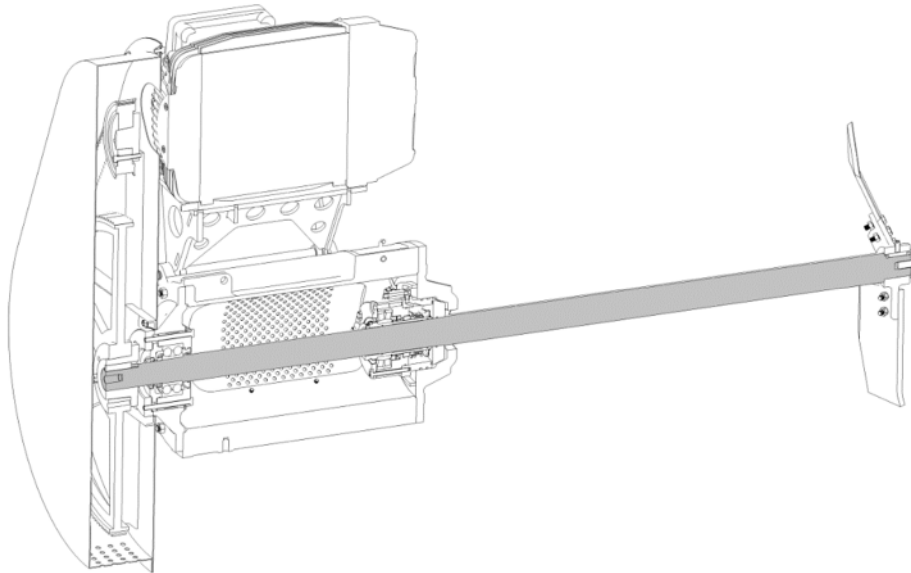

Figure 23: Mixer Assembly with One Piece Impeller Shaft

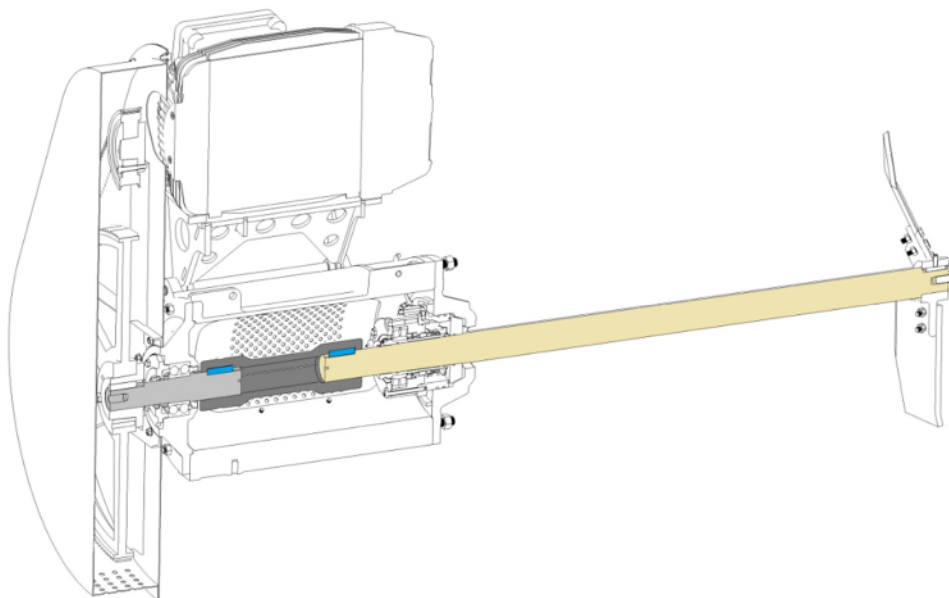

Figure 24: Mixer Assembly with Shaft Coupling

8.10 Belt Drive

8.10.1 Checking the Belt

	Danger!
	To Avoid Possible Injury, Turn Off the Agitator. Lock out and disconnect all power to the drive motor and any optional devices. Turn off and disconnect the lubricant supply.
	Note!
	Do not apply belt dressing during the tensioning procedure as dressing will damage the belt(s) and cause early failure.

Without exception, the most important factor in the successful operation of a belt drive is proper belt tensioning. To achieve the long, trouble-free service associated with belt drives, the belt tension must be sufficient to overcome slipping under maximum peak loads. The general method to increase the tension of the belt drive is to increase the center distance between the two sheaves.

1. If excessive belt wear is evident and multiple belts are present (this is uncommon), replace all belts as a complete set.
2. Check the tension of belt(s) by measuring the deflection force using a tensiometer or equivalent spring scale. Apply a perpendicular force to the belt (or one of the belts) at the midpoint of the span length, **Figure 11**, page 16.
3. Observe the force required to deflect any one belt 1/64 inch for every inch (16 mm/meter) of span length. For example, the deflection for a 32-inch (820 mm) span would be 1/64-inch x 32 inch (16 mm/meter x 0.82 meter), which equals ½ inch (13 mm) of deflection.
4. Achieve correct belt deflection by increasing or decreasing the sheave center distance by adjusting the turnbuckles **[17]** on the motor support base. See Section 6.3 for more details on adjusting the belt.

8.10.2 Replacing the Belt

	Danger!
	To Avoid Possible Injury, Turn Off the Agitator. Lock out and disconnect all power to the drive motor and any optional devices. Turn off and disconnect the lubricant supply.
	Note!
	If multiple belts are used, keep all new belts together as a set separate from other belts. Mixing new and old belts during replacement may result in a loss of power transmitting capability.

1. Remove the belt guard cover **[4A]** from the supporting back panel **[4]**.
2. Reduce the center distance between the sheaves. To do this, loosen the outer turnbuckles' hex jam nuts **[16]**. Loosen the hex bolt and nut **[18, 19]** where the bracket meets the pedestal. Rotate the turnbuckle bodies **[17]** to retract until there is enough clearance for the drive belt to be removed.



3. Make sure the motor shaft remains parallel with the agitator shaft and tightly secured to the mounting base. Loosen the motor bolts and re-align the motor shaft with the mixer shaft as needed to correct any motor shaft to agitator shaft parallel misalignment.
4. Follow the steps in Section 6.3, page 14 to complete the belt installation and alignment.

8.10.3 Dismounting the Flange-In Sheave Hub (Preferred Arrangement)

1. Remove the sheave(s) [1B,3B] from the bushings [1A, 3A] by removing the connecting fasteners [1C, 1D, 3C, 3D] and inserting the bolts into the threaded jacking screw holes (A) in the sheave hub.
2. Tighten the bolts equally against the bushing flange to break the grip of the split “QD” bushing on the shaft and allow the sheave to slide off freely. No wheel puller or heavy tool is necessary to remove the sheave.
3. Loosen the setscrews in the bushing over the key. Remove the bushing from the shaft.

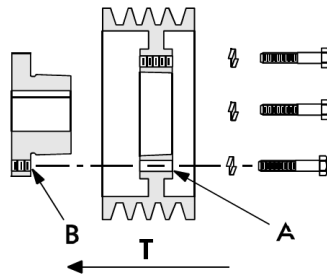

Figure 25: Hub Flange-In Dismounting

8.10.4 Dismounting the Flange-Out Sheave Hub

1. Remove the sheave [1B,3B] from the bushing [1A,3A] by removing the connecting fasteners [1C, 1D, 3C, 3D] and inserting the bolts into the threaded jacking screw holes (A) in the bushing flange.
2. Tighten the bolts equally up against the sheave hub to break the grip of the split “QD” bushing on the shaft and allow the sheave to slide off freely. No wheel puller or heavy tool is necessary to remove the sheave.
3. Loosen the setscrews in the bushing over the key. Remove the bushing from the shaft.

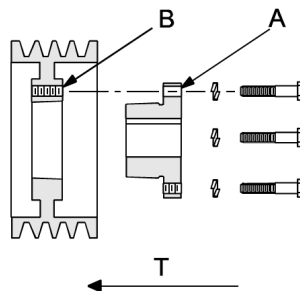

Figure 26: Hub Flange-Out Dismounting



9 Item List for SB Mixer

Item No.	Description	Qty
1	Motor Sheave	1
1A	Bushing, Sheave Motor	1
1B	Sheave, Motor	1
1C	Lock Washer	Varies
1D	Bolt	varies
2	Drive Belt	1
3	Impeller Sheave	1
3A	Bushing, Sheave Ext. Shaft	1
3B	Sheave, Ext. Shaft	1
3C	Lock Washer	Varies
3D	Bolt	Varies
4	Belt Guard, Backing Plate	1
4A	Belt Guard, Outer Shell	1
4B	Belt Guard, Inspection Cover	1
4C	Hex Bolt	Varies
4D	Hex Nut	Varies
5	Shaft Coupling (optional)	1
6	Pedestal	1
7	Seal Assembly	1
8	Mounting Flange	1
9	Plug, Plumbing Access	1
10	Pedestal Guard (not shown)	2
11	Motor Mount	1
12A	Lock Washer	4
12B	Hex Nut	4
12C	Hex Bolt	4
13	Motor	1
14	Impeller Shaft	1
15	Impeller	1
16	Hex Jam Nut	4
17	Turnbuckle	2
18	Hex Bolt	1
19	Hex Nut	1
21	Hex Nut	12
22	Lock Washer	12
23	Hub	1
24	Blade	3
25	Hex Bolt	12
26	Hex Bolt	1
27	Flat Washer	1



Item No.	Description	Qty
28	Key	1
29	Set Screw	1
41	Cover, Bearing	1
42	Hex Bolt	4
43	Lock Washer	4
44	Socket Head Cap Screw	2
45	Relief Fitting	1
46	Retaining Ring	1
47	Housing	1
48	Lip Seal	1 or 2
49	O-ring Seal	1
50	Single Mechanical Seal	1
51	Retaining Ring	1
52	Shaft Sleeve	1
53	O-ring Seal	2
54	Leak Detection Plug	1
55	Bearing	1
56	O-ring Seal	1
57	Grease Fitting	1
58	Lip Seal	1
59	Set Screw	3
61	Leak Detection Valve/Vent	1
62	Clamping Bolt	4
63	Seal Gland	1
64	Spacer	2
65	Seal Cavity Plug	1
66	Socket Head Shoulder Bolt	2
72	Socket Head Cap Screw	2
73	O-ring Seal	1
74	Double Mechanical Seal	2
75	Seal Housing	1
76	Outlet Fitting	1
77	Inlet Fitting	1
82	Outboard Drive Shaft	1
90	Hex Bolt	4
91	Bearing Cap	1
92	Tapered Snap Ring	1
93	Set Screw	3
94	Shaft Sleeve	1
95	Lip Seal	1
96	Key	1
97	O-ring	1



Item No.	Description	Qty
98	Bearing	1
99	Stud	8
100	Hex Nut	8
101	Grease Fitting	1
102	Lip Seal	1
103	Grease Relief Fitting	1
104	Spacer (2-piece shaft only)	1
105	Bearing Housing	1



10 Appendix

Tighten all fasteners to values shown unless specifically instructed to do otherwise. Lubricate all fasteners at assembly with thread lubricant or an anti-seize material. Bolt threads and contact surfaces of bolt heads and nuts should be lubricated. Note that stainless steel and alloy fasteners can gall while being tightened. The risk of galling or thread seizing is reduced by using lubrication, by tightening fasteners with low rpm's and without interruptions, and applying only light pressure. Dry fasteners, components with dirt or dust, bolting faces with rough finish, or even some environmental factors such as heat or moisture can effect the torque readings, and require values different than those listed in the table below.

Table 20: Bolt Tightening Torque

BOLT SIZE	SAE J429 CARBON STEEL						STAINLESS STEEL	
	GRADE 2 METRIC GRADE 4.6		GRADE 5 METRIC GRADE 8.8		METRIC GRADE 12.9		300 Series Stainless Steel (e.g. 304, 316)	
	ft-lb	Nm	ft-lb	Nm	ft-lb	Nm	ft-lb	Nm
1/4 - 20	-	-	6	8.1	-	-	4.1	5.6
5/16 - 18	-	-	13	18	-	-	8	11
3/8 - 16	-	-	23	31	-	-	15	20
1/2 - 13	38.0	52	55	75	-	-	38	52
9/16 - 12	50.0	68	79	107	-	-	50	68
5/8 - 11	68.0	92	110	149	-	-	68	92
3/4 - 10	120.0	163	195	264	-	-	95	129
7/8 - 9	122.0	165	314	426	-	-	153	207
1 - 8	184.0	250	470	637	-	-	230	312
1-1/8 - 7	260.0	353	587	796	-	-	326	442
1-1/4 - 7	368.0	499	828	1123	-	-	460	624
1-3/8 - 6	482.0	654	1085	1471	-	-	602	816
1-1/2 - 6	640.0	868	1440	1953	-	-	800	1085
M6 x 1.00	3.8	5.1	6.9	9.4	9.7	13	4.3	5.8
M8 x 1.25	8	10	17	23	24	32	10	14
M10 x 1.50	15	20	34	45	47	63	21	28
M12 x 1.75	26	35	58	79	81	110	36	49
M16 x 2.00	64	87	145	196	202	274	89	121
M20 x 2.50	126	170	282	383	394	534	174	236
M24 x 3.00	217	295	489	663	537	728	300	407

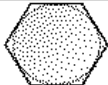
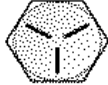
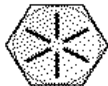
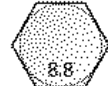
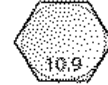

Table 21: Bolt Tightening Torque (Contd.)

BOLT SIZE	ALLOY 600 (UNS#N06600), ALLOY C4 (UNS#N06455), ALLOY G30 (UNS#N06030), ALLOY 2205 (UNS#S32205)		ALLOY C276 (UNS#N10276), ALLOY C2000 (UNS#N06200)		ALLOY 20 (UNS#N08020), ALLOY 400 (UNS#N04400), ALLOY 825 (UNS#N08825)	
	ft-lb	Nm	ft-lb	Nm	ft-lb	Nm
1/4 - 20	4	5.4	5	6.8	3.4	4.6
5/16 - 18	8	11	10	14	7	9
3/8 - 16	15	20	18	25	12	17
1/2 - 13	36	49	45	61	30	41
9/16 - 12	52	70	65	88	43	59
5/8 - 11	72	97	89	121	60	81
3/4 - 10	127	172	159	215	106	143
7/8 - 9	205	277	256	347	170	231
1 - 8	307	416	383	520	256	346
1-1/8 - 7	435	589	543	737	362	491
1-1/4 - 7	613	832	767	1040	511	693
1-3/8 - 6	804	1090	1005	1363	670	908
1-1/2 - 6	1067	1447	1334	1809	889	1206
M6 x 1.00	3.7	5.0	4.9	6.6	3.1	4.2
M8 x 1.25	9	12	12	16	7	10
M10 x 1.50	18	24	24	32	15	20
M12 x 1.75	31	42	41	56	26	35
M16 x 2.00	77	104	102	139	64	87
M20 x 2.50	150	203	200	271	125	169
M24 x 3.00	276	374	345	468	216	292



Table 22: Bolt Grades and Mechanical Properties

Head Marking	Grade and Material	Nominal Size Range (inches)	Mechanical Properties		
			Proof Load (psi)	Min. Yield Strength (psi)	Min. Tensile Strength (psi)
US Bolts					
 No Markings	Grade 2 Low or medium carbon steel	1/4 thru 3/4	55,000	57,000	74,000
		Over 3/4 thru 1-1/2	33,000	36,000	60,000
 3 Radial Lines	Grade 5 Medium Carbon Steel, Quenched and Tempered	1/4 thru 1	85,000	92,000	120,000
		Over 1 thru 1-1/2	74,000	81,000	105,000
 6 Radial Lines	Grade 8 Medium Carbon Alloy Steel, Quenched and Tempered	1/4 thru 1-1/2	120,000	130,000	150,000
Stainless markings vary. Most stainless is non-magnetic	18-8 Stainless Steel alloy with 17-19% Chromium and 8-13% Nickel	1/4 thru 5/8		40,000 Min. 80,000 – 90,000 Typical	100,000 – 125,000 Typical
		3/4 thru 1		40,000 Min. 45,000 – 70,000 Typical	100,000 Typical
		Above 1			80,000 – 90,000 Typical
Head Marking	Class and Material	Nominal Size Range (mm)	Mechanical Properties		
			Proof Load (MPa)	Min. Yield Strength (MPa)	Min. Tensile Strength (MPa)
Metric bolts					
 8.8	Class 8.8 Medium Carbon Steel, Quenched and Tempered	All Sizes below 16mm	580	640	800
		16mm - 72mm	600	660	830
 10.9	Class 10.9 Alloy Steel, Quenched and Tempered	5mm - 100mm	830	940	1040
12.9	Class 12.9 Alloy Steel, Quenched and Tempered	1.6mm - 100mm	970	1100	1220
Stainless markings vary. Most stainless is non-magnetic. Usually stamped A-2	A-2 Stainless Steel alloy with 17- 19% Chromium and 8-13% Nickel	All Sizes thru 20mm		210 Min. 450 Typical	500 Min. 700 Typical
Tensile Strength: The maximum load in tension (pulling apart) which a material can withstand before breaking or fracturing. Yield Strength: The maximum load at which a material exhibits a specific permanent deformation Proof Load: An axial tensile load which the product must withstand without evidence of any permanent set. 1MPa = 1N/mm ² = 0.2248 pounds/mm ²					

(Source: www.boltdepot.com)