

DT Small Mixers Installation, Operation, Maintenance Manual

Equipment Reference:
60DTD Style Mixer

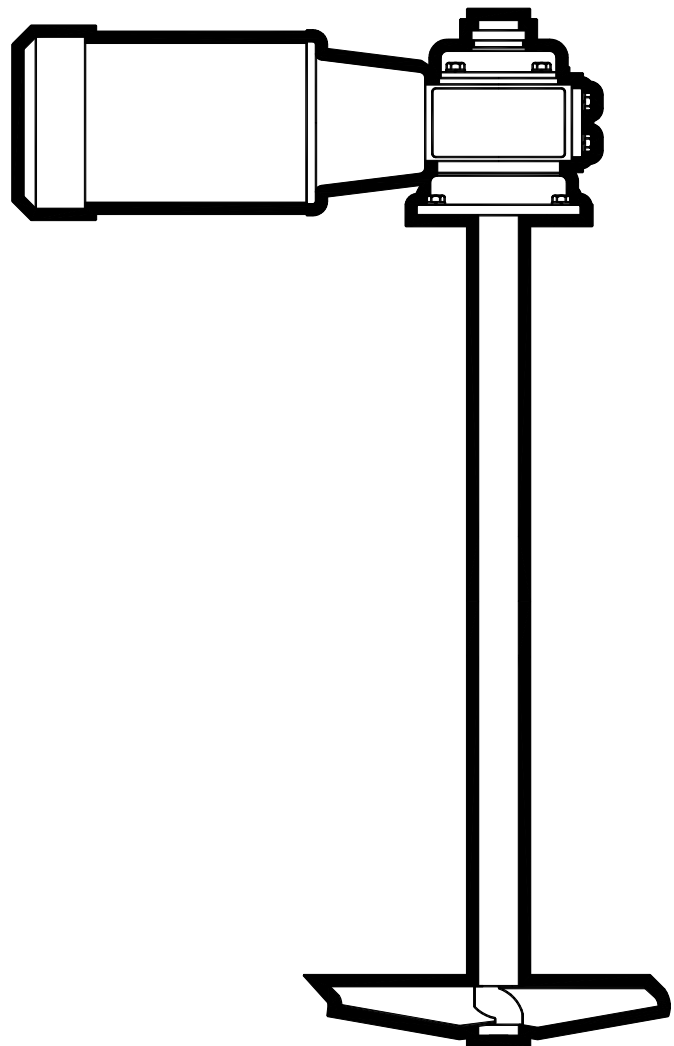

TABLE OF CONTENTS

Initial Inspection	1
Chemineer Assistance	1
Storage	2
Mounting & Installation	3
Open Tank Mixer Installation	3
Mixer Installation	12
Lubrication	15
Electric Motor	15
Air Motor	15
Gear Drive	15
Operation	16
Mixer	16
Electric Motors	17
Air Motors	17
Gear Drive	17
Maintenance	18
Mixer Maintenance – Mixer Removal & Disassembly	18
Mixer Maintenance – Mixer Assembly	20
Parts	22

TABLE OF CONTENTS

Tables	Page
Table 1: Recommended Beam Sizes	3
Table 2: Off-Center Positioning	11
Table 3: Bolt Tightening Torque	14
<hr/>	
Figures	
Figure 1: Model 60DTD, Installation	4
Figure 2: Extension Shaft Installation	6
Figure 3: Model 60DT	7
Figure 4: Shaft Guard Installation	8
Figure 5: Angle Riser Mounting	9
Figure 6: Angle Mount Installation	10
Figure 7: Wiring Diagram, Motors	13

INITIAL INSPECTION

Step 1: Inspect crates. Upon receipt, inspect all crates and equipment for shipping damage. Report shipping damage to your local Chemineer office or to the factory in Dayton, Ohio. A claim should be filed immediately with the carrier involved.

Step 2: Uncrate. Check the contents. Do not uncrate the unit until you have read the *Mounting & Installation* section of this manual and looked at the assembly drawing shipped with the unit. Be careful in uncrating and handling. Do not discard the crating without making sure that all mixer parts have been removed. Correct assembly of this unit requires referring to both the unit assembly drawing and this manual.

Step 3: Questions? Call Chemineer. If the shipment is not complete or you do not understand what you have received, please contact *your local Chemineer office* immediately.

CHEMINEER ASSISTANCE

Chemineer maintains a fully staffed Parts and Field Service Department ready to help you with any service requirement. Simply contact your local Chemineer office, or contact Parts/Field Service at the Chemineer Factory in Dayton, Ohio:

Chemineer, Inc.
P.O. Box 1123
Dayton, Ohio 45401
Phone: (937) 454-3200
FAX: (937) 454-3375

Services available are as follows:

Installation and maintenance training seminars,
Installation and start-up supervision,
Preventative maintenance planning,
Parts order service,
Special instructions.

STORAGE

Do not remove any protective packaging, coatings (generally applied to the motor output shaft), or any protective coverings that may be applied to the wetted parts until the mixer is to be put into service. If the equipment is to be stored, *do not stack crates*. Store in a clean dry indoor location that is free from wide variations in temperature. The storage area should be free from vibration and excessive heat.

Inspect for external rust at six-month intervals. Apply rust preventative as required. If the unit has been in storage for more than six months or subjected to adverse moisture conditions, the motor windings may have to be dried prior to operation.

CAUTION! Coated/rubber covered agitator parts require special handling to avoid damage to coatings/rubber coverings. Do not use chains or hooks on coated/covered surfaces. Special care is required to prevent damage to edges and outside corners. Contact Chemineer Field Service for instructions.

Short-Term Indoor Storage

Mixers should be stored indoors in areas with no vibration and relatively constant temperatures and humidity. The factory storage preparations should be acceptable for up to six months storage.

Rotate the gear drive output shaft by rotating the extension shaft 10 to 15 revolutions at least once per month to reduce the possibility of brinelling of the bearings and to redistribute bearing grease.

OPEN TANK MIXER INSTALLATION

Refer to the mixer assembly drawing for the required support structure design loads.

In designing the structure to accommodate bending moment, the structure should be sufficiently rigid so that the mixer extension shaft will not move more than 1/64 inch (.4mm) per foot of length due to deflection of the mounting system.

The agitator support in open tanks is typically constructed of two steel beams with lateral bracing. See *Table 1, below* for beam size.

TABLE 1: RECOMMENDED BEAM SIZES

MODEL	TANK DIAMETER, FT (M)											
	2 (.61)	2.5 (0.76)	3 (0.91)	4 (1.22)	5 (1.52)	6 (1.83)	7 (2.13)	8 (2.44)	9 (2.74)	10 (3.05)	12 (3.66)	
60DTD	L2x2x3/16			L2.5x2.5x1/4						C3x4.1		

 Cells shaded in gray are “not recommended”.

Diagonal bracing (45 degree) should be used between the span beams. The ends of the span beams should be boxed in. Both lateral bracing and diagonal bracing to be identical to span beams.

Refer to *Figure 1, page 4* for mounting dimensions.

OPEN TANK MIXER INSTALLATION

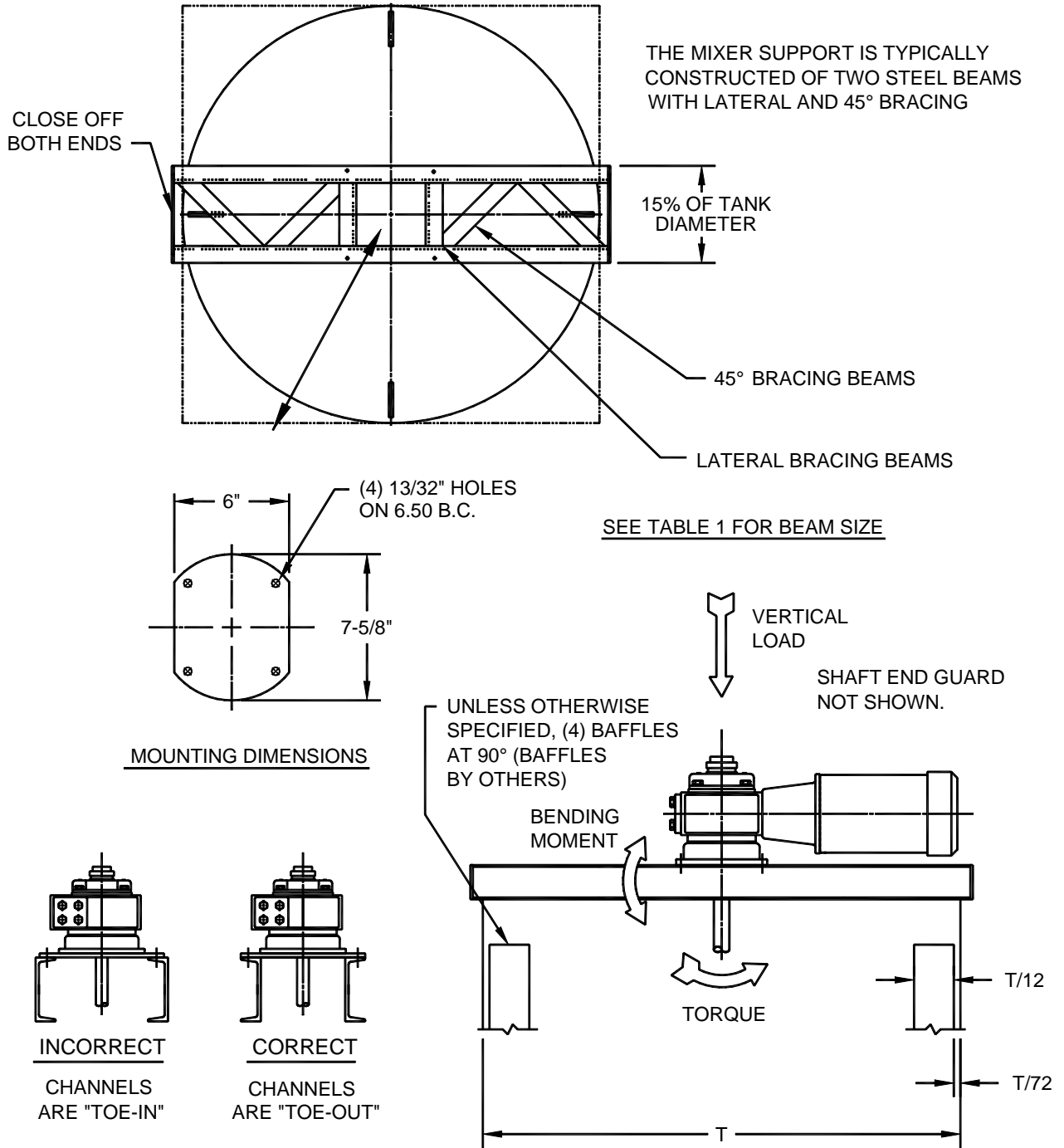

Figure 1: Model 60DTD, Installation

OPEN TANK MIXER INSTALLATION

Correct unit installation requires both the unit assembly drawing and this manual.

The model 60DTD is a gear reduced, beam mount mixer. The drive unit is typically shipped with the motor [100] mounted to the gear reducer [200]. Also in the main unit box will be the shaft guard assembly [295], the impellers [500] and all other required accessories. Shafting [400] is shipped separately.

Be certain to locate all contents before discarding packaging materials.

1. Remove all shipping constraints. A nylon strap, or similar, should be secured around the motor/gear reducer drive assembly to lift and move the mixer. Please note the approximate net weight of the unit as shown on the assembly drawing and use caution when moving or lifting these items. *At no point during installation or maintenance of the mixer, should the extension shaft ever be used as a lifting point!*

WARNING: *DO NOT connect the mixer to the power source until the unit is fully assembled and properly positioned in the vessel.*

2. Mount the motor/reducer drive assembly to support structure using customer supplied fastener set (3/8" bolts). Refer to *Figure 2, page 6*.

The mixer should never be mounted with the shaft and propeller(s) installed.

3. Clean the mixer extension shaft [400] and reducer slow speed shaft [264]. Make sure both surfaces are completely dry and free from any burrs or nicks.
4. Install the shaft key [288] into the extension shaft keyway making sure it is fully bottomed into the keyway. Insert the mixer extension shaft [400] into the reducer slow speed shaft [264] being careful not to install the shaft at an angle to the reducer. Lift shaft through reducer until the machined recess on the upper end of the shaft is clearly visible above the top collar of the reducer slow speed shaft.
5. Install snap ring [289] over shaft end and slide into groove on extension shaft. Lower shaft until snap ring rests on top collar of reducer slow speed shaft [264]. Install and tighten setscrews [272]. Refer to *Figure 2*.
6. Install breather [290] on top of gear drive. Reference *Figure 7, page 19*.
7. Eight plastic plugs have been inserted into the two opposite sides of the reducer. Remove the upper two plugs on each side and install shaft guard [296] as shown in *Figure 4, page 8*.

OPEN TANK MIXER INSTALLATION

- For single impeller assemblies, install the impeller with the lower hub face even with the shaft end. Impeller orientation should allow the driving edge of the impeller to pump toward the bottom of the mixing vessel. Tighten the impeller setscrews (typically quantity two).

For dual impeller assemblies, space the upper impeller at a recommended minimum of two impeller diameters and maximum of three impeller diameters above the lower impeller. The lower impeller should be a minimum of one impeller diameter below the liquid surface at all times during mixer operation.

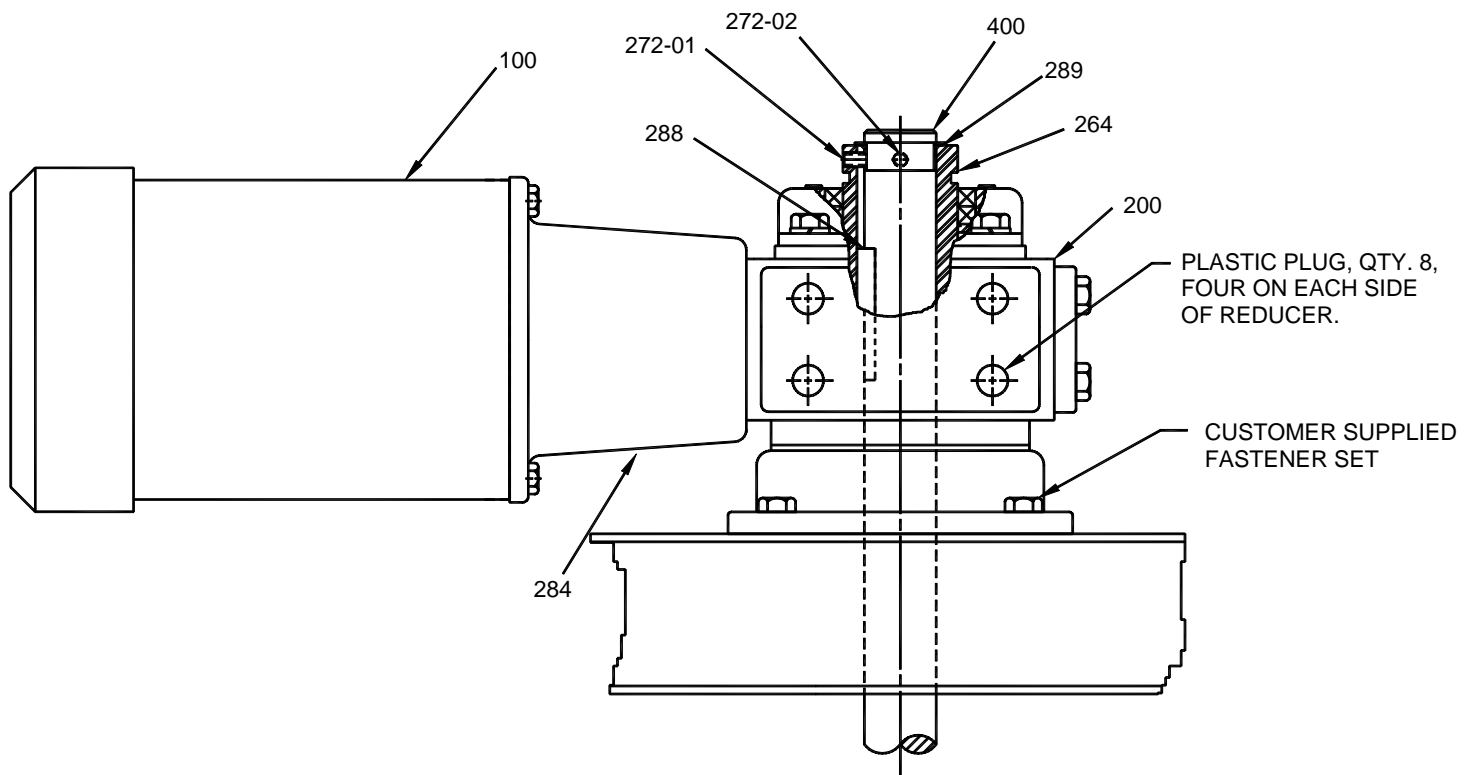

Figure 2: Extension Shaft Installation

OPEN TANK MIXER INSTALLATION

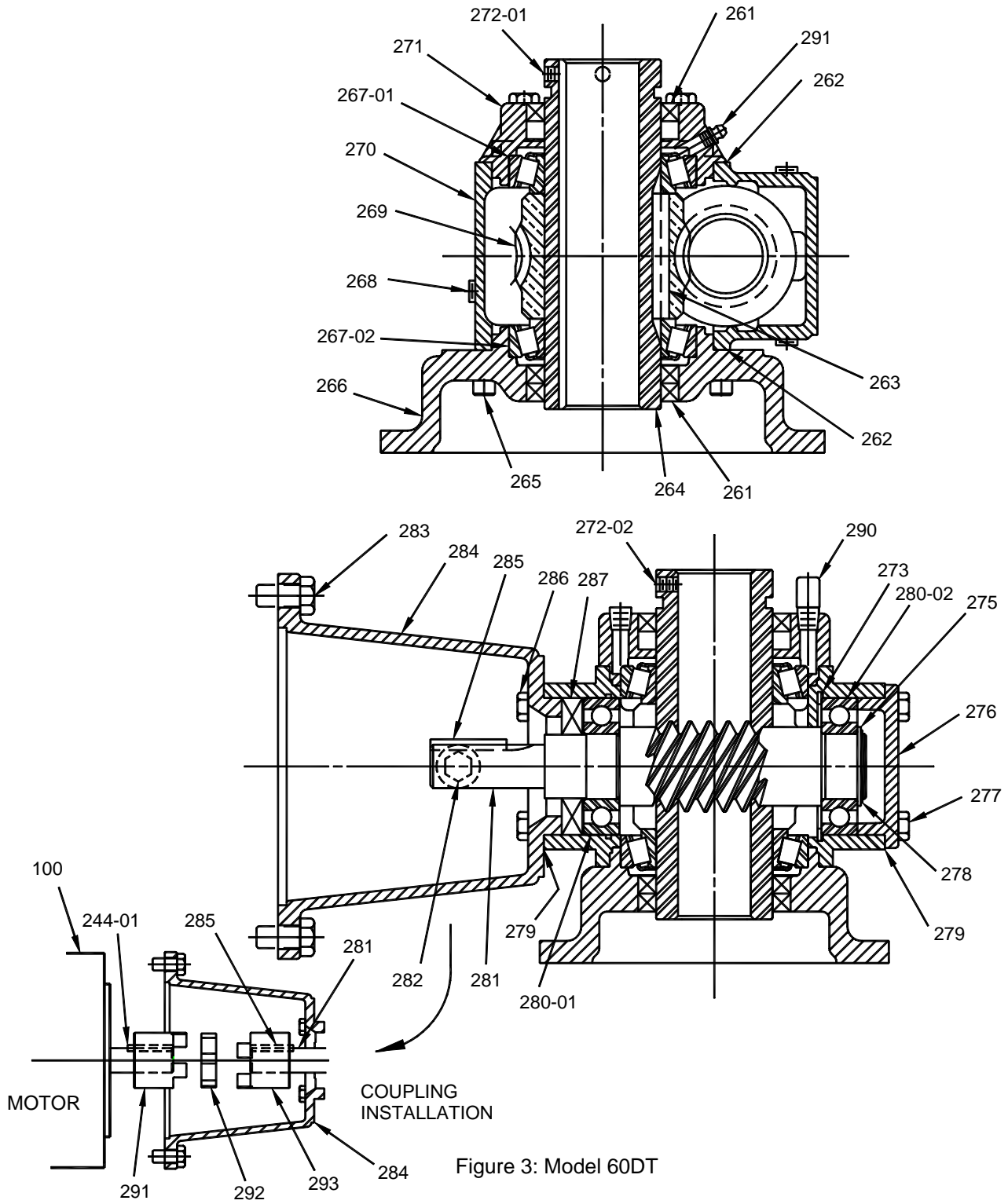

Figure 3: Model 60DT

OPEN TANK MIXER INSTALLATION

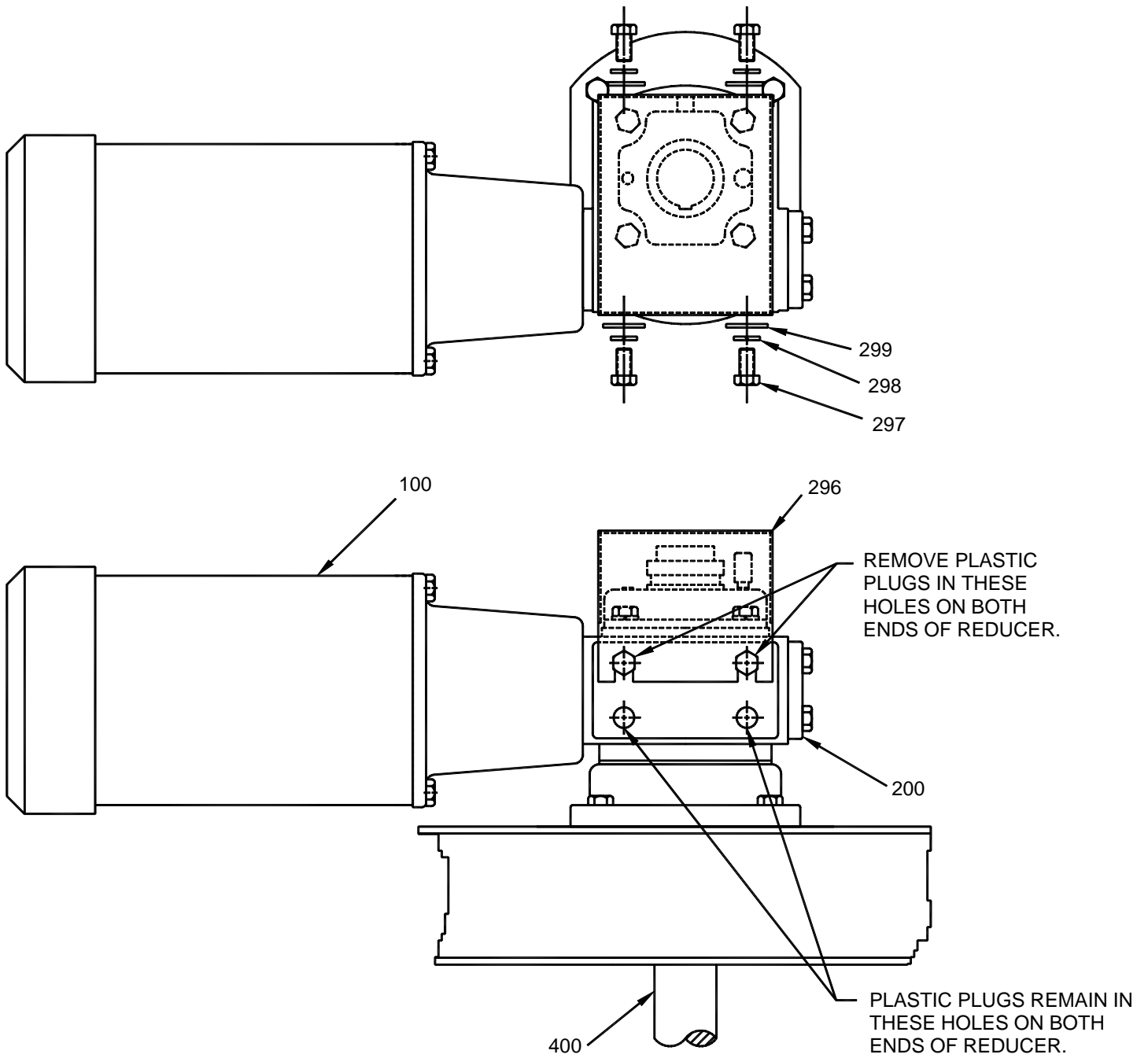

Figure 4: Shaft Guard Installation

OPEN TANK MIXER INSTALLATION OPTIONAL ANGLE RISERS

Model 60DTD mixers may be angle mounted to 10 degrees off vertical. See *Figure 6, page 10* for angle mount installation information.

The drive unit must be angle mounted with the motor mounted on the low side. The motor will be parallel to the floor if mounted correctly. Unit will attach to support structure using customer supplied angle risers and mounting fasteners.

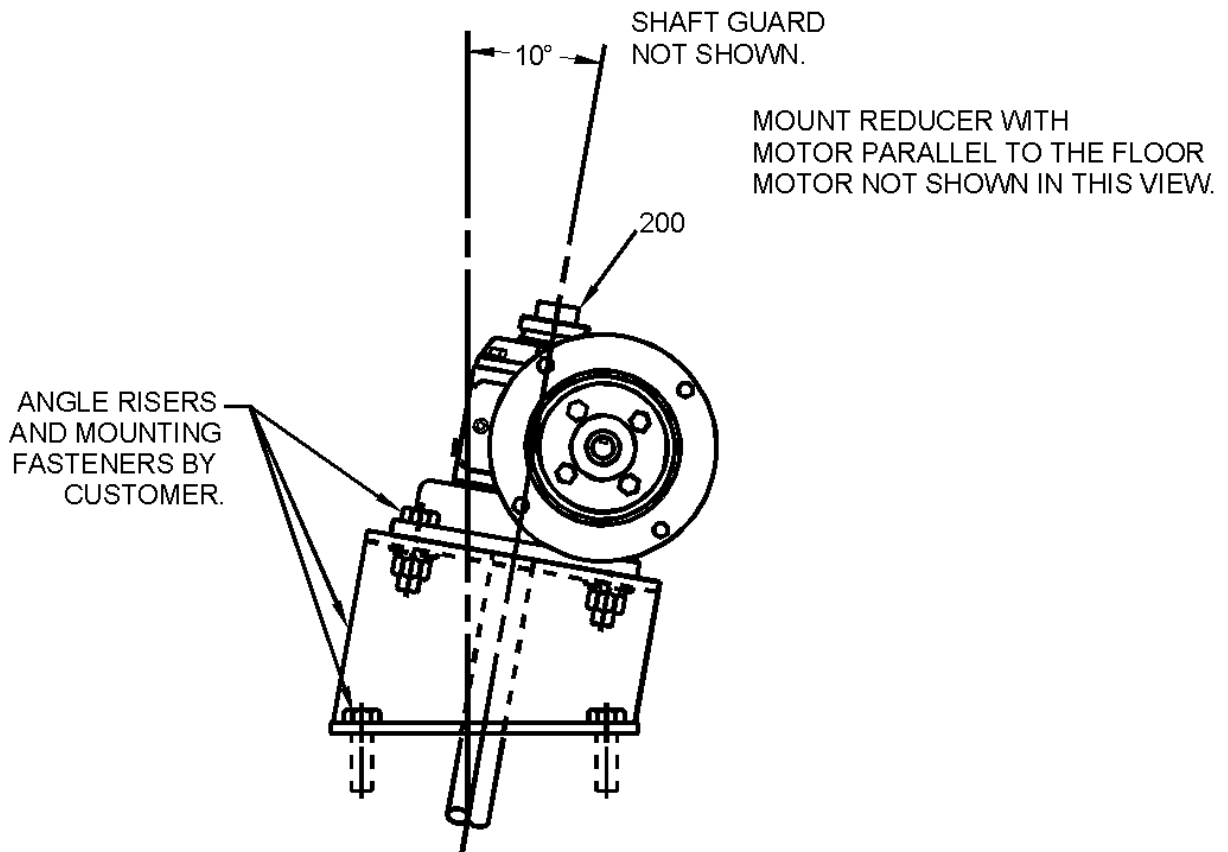
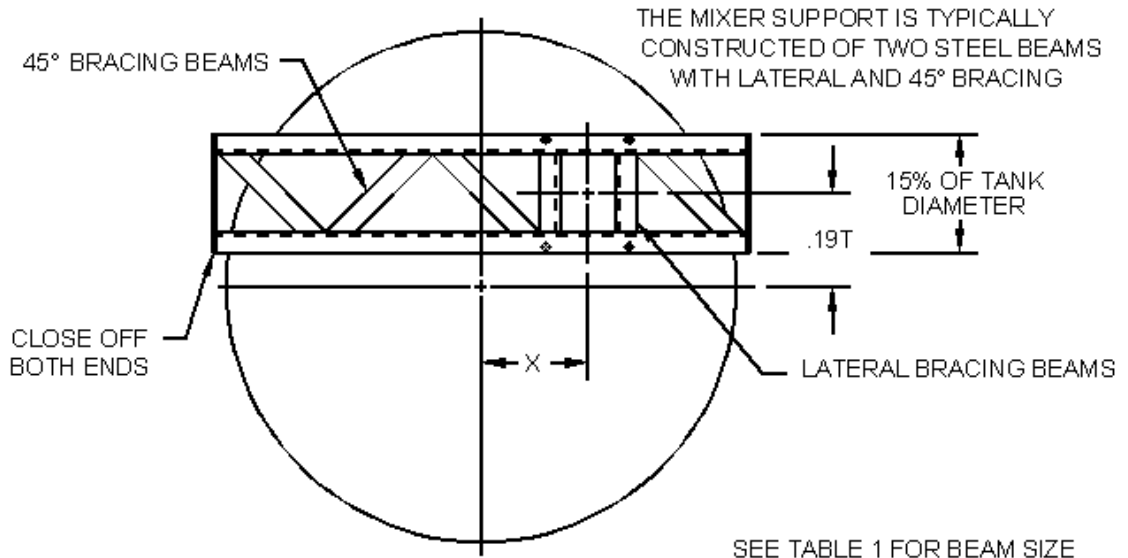

Figure 5: Angle Riser Mounting

**OPEN TANK MIXER INSTALLATION
OPTIONAL ANGLE RISERS**



ANGLE RISERS SUPPLIED BY CUSTOMER.

SEE TABLE 2 FOR OFF-CENTER POSITION DIMENSION "X"

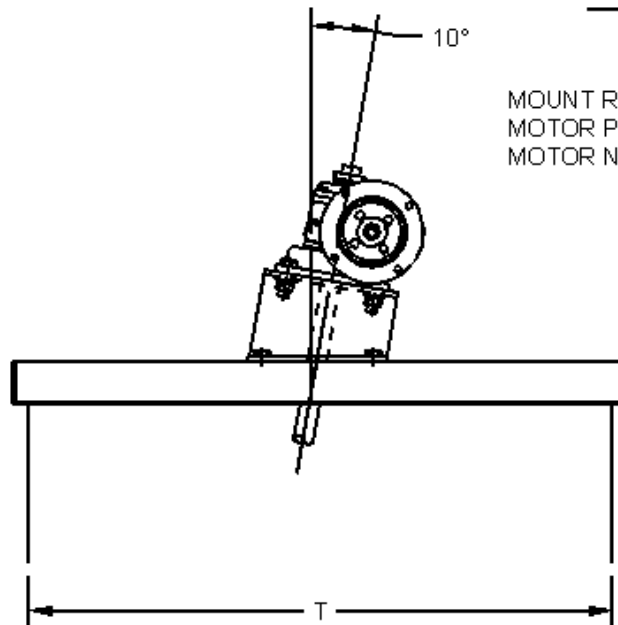

Figure 6: Angle Mount Installation

**OPEN TANK MIXER INSTALLATION
OPTIONAL ANGLE RISERS****TABLE 2: OFF-CENTER POSITIONING**

SHAFT EXTENSION RANGE IN (MM)	“X” DIMENSION, IN (MM)	MINIMUM TANK DIAMETER “T”, IN (MM)
20” – 37” (508 – 940)	5” (127)	18” (457)
38” – 53” (965 – 1346)	7.5” (191)	22” (559)
54” – 76” (1372 – 1930)	10.75” (273)	32” (813)
77” – 110” (1956 – 2794)	15.5” (394)	46” (1168)
111” – 135” (2819 – 3429)	21.25” (540)	64” (1626)

MIXER INSTALLATION ELECTRIC MOTORS

1. Check the nameplate data on the motor to assure that the available power supply agrees with the motor requirements. Protective devices should be of the proper size and rating to safely carry the load and interrupt the circuit on overloads.
2. If the motor has been stored in a damp location, the windings may require drying.

NOTE: Do not obstruct the normal flow of ventilating air through or over the motor.

3. Many of the motors supplied with this product are dual voltage. The motor cord supplied with a single phase motor is applicable for use on 125VAC systems only. Customer is responsible for supplying all necessary motor connections and for properly wiring the motors. Refer to wiring diagram *Figure 7, page 13* for normal motor connections. Consult *Chemineer Field Service* if there are any questions pertaining to the installation or operation of the motor or mixer unit.
4. Connect the motor in accordance with the National Electric Code and local requirements, but do not make the connections permanent until the motor rotation has been checked. Jog the motor to check for correct rotation prior to securing wiring. Refer to unit assembly drawing for unit rotation direction.
5. If any additional motor auxiliary devices such as space heaters or temperature sensors are used, connect them in proper circuits and insulate them from motor power cables.

AIR MOTORS

1. Air motors are designed to be driven by compressed air. Under no circumstances should they be driven with any other type of gas, fluids, particles, solids, or any substance mixed with air.
2. The muffler is shipped uninstalled on the air motor. Always install a moisture trap and filter in the air line ahead of the motor.
3. "Reversible" type air motors will work equally in both directions. A 4-way valve may be connected to both air ports to allow reversible operation. For efficiency of output and control of speed, use air lines of the same size or the next larger pipe size than the intake port of the motor.
4. *Lubrication of the air motor is required.* Refer to **Lubrication** section of this manual for more information.

MIXER INSTALLATION

**SINGLE-PHASE MOTOR
(WITHOUT THERMAL PROTECTOR)**

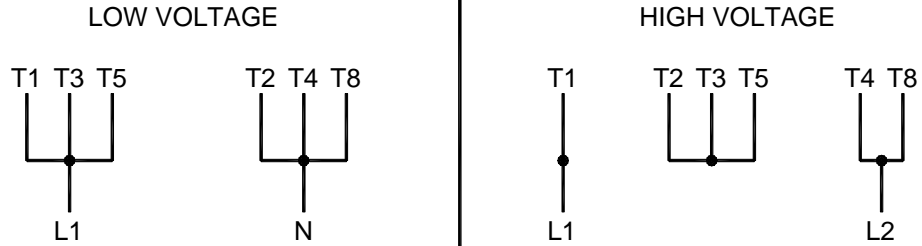

CCW ROTATION (LOOKING AT THE MOTOR FROM THE SHAFT END)

NOTE: TO REVERSE MOTOR SHAFT ROTATION,
INTERCHANGE MOTOR LEADS T5 AND T8

**THREE-PHASE MOTOR
(WITHOUT THERMAL PROTECTOR)**

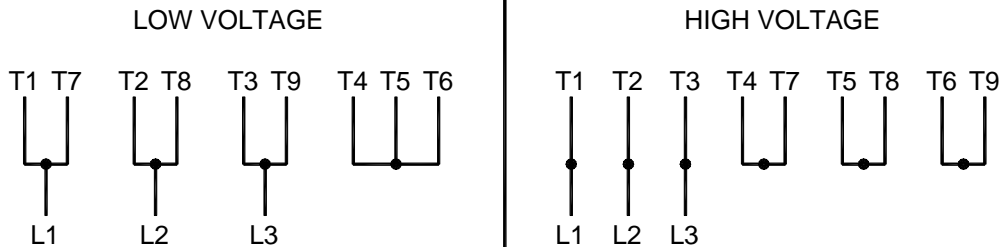

NOTE: TO REVERSE MOTOR SHAFT ROTATION,
INTERCHANGE ANY TWO LINE LEADS

CHECK MOTOR LEADS WITH CONNECTION DIAGRAMS ON MOTOR
NAMEPLATE OR CONDUIT BOX FOR PROPER WIRING

CHECK THE MIXER SHAFT ROTATION AGAINST THE PROPER
ROTATION INDICATED ON THE ASSEMBLY DRAWING

NOTE:
THE NORMAL MOTOR SHAFT ROTATION SHOULD BE CCW WHEN
LOOKING AT THE MOTOR FROM THE SHAFT END.
THE NORMAL MIXER SHAFT ROTATION IS CW WHEN LOOKING INTO THE
TANK FOR STANDARD ROTATION IMPELLERS.

Figure 7: Wiring Diagram, Motors

MIXER INSTALLATION

TABLE 3: BOLT TIGHTENING TORQUE

BOLT SIZE	CARBON STEEL ⁽¹⁾				300 SERIES STAINLESS ⁽²⁾	
	GRADE 2		GRADE 5		Ft-lb	Nm
	Ft-lb	Nm	Ft-lb	Nm		
1/4-20	4.1	5.6	6	8.1	4.1	5.6
5/16-18	8.3	11	13	17	8.3	11
3/8-16	15	20	23	31	15	20
1/2-13	38	51	56	76	38	51
5/8-11	68	92	113	153	68	92
3/4-10	120	163	200	271	120	163

Tighten all fasteners to values shown unless specifically instructed to do otherwise. Lubricate all fasteners at assembly with grease, oil or an anti-seize material. Bolt threads and contact surfaces of bolt heads and nuts should be lubricated.

⁽¹⁾If fasteners cannot be lubricated, multiply table values by 1.33.

⁽²⁾If fasteners cannot be lubricated, multiply table values by 1.25.

LUBRICATION

This section defines the proper oils and greases that must be used with this equipment.

ELECTRIC MOTOR

All 56C frame size motors supplied with this product have the motor bearings properly greased by the manufacturer and should not require re-lubrication for the life of the mixer. Always refer to the motor nameplate for lubrication requirements.

AIR MOTOR

Lubrication of the air motor is required. An automatic air line lubricator must be installed in the air line just ahead of the air motor. The lubricator should be adjusted to feed one drop of oil for every 50-75 CFM of air going through the motor. Detergent SAE #10 automotive engine oil or equivalent is the recommended air motor lubricant.

GEAR DRIVE

The gear drive has been filled with synthetic oil at the factory. The oil level should be checked and adjusted (if necessary) prior to operation, using the oil level plug provided on the unit. This check should occur while the unit is in its operating position. For ambient temperatures from -30°F (-34°C) to 165°F (74°C), lubricate gear drive Mobil SHC629 or equal. *Do not use a phosphorous based oil.*

The oil in a new reducer should be changed at the end of 250 hours of operation. Subsequent oil changes should occur after every 2500 hours of operation, or every six months, whichever occurs first. High ambient operating temperatures, excessive moisture, dust, corrosive fumes, and/or wide temperature fluctuations will require more frequent replacement of lubricant. Even under normal operating conditions, it is recommended that you inspect the gear drive regularly for lubricant leaks, abnormal noise, vibration, etc.

Some units are equipped with grease fittings to lubricate bearings not adequately lubricated by the oil splash. These fittings must be lubricated every 3-6 months depending on operating conditions. Bearing greases must be compatible with the type of gear lubricant being used. For synthetic oils, use a synthetic bearing grease such as Mobil Synthetic Universal grease, Mobilith SHC 100 or a suitable equivalent.

A breather [290] has been supplied separately, and should be installed on the top of the gear drive to allow pressures inside and outside the gearcase to equalize. Do not obstruct its function.

MIXER

Proper operating procedures will allow maximum performance of your Chemineer DT Mixer. The following list will aid in the safe operation of your unit.

- **Do not** operate the unit before reading and following the instructions on all tags and nameplates attached to the unit.
- **Do not** operate the unit with less than one impeller's diameter liquid coverage above the lowest impeller. Increased side loading caused by operations at liquid level will decrease unit life.
- **Do not** operate the unit in a fluid with a specific gravity or viscosity higher than that for which the unit was designed.
- **Do not** attempt to start the unit with the mixing impeller buried in solids or a "set up" fluid.
- **Do not** locate tank internals or other rotating equipment close to the mixer impellers or extension shaft.
- **Do not** make any modifications to the mixer unit in the field (i.e. motor horsepower, mixer speed, shaft length, impeller diameter, etc.) without reviewing the change with *your local Chemineer office or Chemineer Field Service.*

CAUTION: There may be a speed range where the unit cannot be operated because of shaft resonant frequency. This range must be avoided or passed through quickly or destructive forces can be generated. Refer to main unit assembly drawing for speed range information or consult *your local Chemineer office.*

Should there be problems operating the unit, confirm that the installation is correct. If you are unable to resolve the problem, contact *your local Chemineer office.*

ELECTRIC MOTORS

Air circulation is very important to get full performance and long life from an electric motor. Do not block the suction inlets on fan-cooled motors. Motor life will be decreased if its temperature exceeds its thermal rating. The allowable temperature is stamped on the motor nameplate.

Prior to permanently wiring the electric motor:

- Check nameplate data on motor to assure that the available power supply agrees with the motor requirements. Protective devices should be the proper size and rating to safely carry the load and to interrupt the circuit on overloads.
- Check motor leads with connection diagrams on motor nameplate and/or conduit box so that the proper connections are made. All motors should be installed in accordance with the National Electric Code and local requirements.
- Check the output shaft rotation against the proper rotation indicated on the assembly drawing. For standard three-phase electric motors, the rotation is reversed by switching any two power leads.
- Check operating motor amperage against nameplate amperage.

The motor should start quickly and run smoothly. If the motor should fail to start or make abnormal noise, immediately shut motor off, disconnect it from the power supply, and investigate the cause. If the problem cannot be corrected, contact *your local Chemineer office* for assistance.

AIR MOTORS

Air motors are designed to be driven by compressed air. Under no circumstances should they be driven with any other type of gas, fluids, particles, solids, or any substance mixed with air.

Operating pressures should not exceed 100psi (689 kPa). The speed and torque can be regulated by using a pressure regulator or shut-off valve to obtain the desired power and conserve air.

GEAR DRIVE

The normal gear drive operating temperature can reach 200°F (93°C). The surface temperature should not exceed 200°F (93°C). Should a temperature of greater than 200°F (93°C) exist, review the installation for unusually high ambient conditions, poor air circulation, or other unusual conditions.

MIXER MAINTENANCE

Refer to *Figure 2, page 6 and Figure 3, page 7*.

Mixer Removal & Disassembly

CAUTION: Prior to removing mixer, review the installation to assure that all safety issues are resolved.

1. Lock out and disconnect all power to the mixer motor and any optional devices.
2. Remove the shaft guard assembly [295].
3. Loosen the setscrews [272] and raise the extension shaft [400] enough to remove the snap ring [289]. Carefully lower shaft through reducer [200] and remove shaft key [288].
4. Remove the mixer drive unit from the tank and move to a suitable service area.
5. Remove the motor mounting bolts [283]. Carefully separate and remove the motor [100] from the motor adapter bell housing [284]. Loosen coupling half [293] setscrew on reducer high speed shaft [281] and remove coupling half. Remove high speed shaft key [285].
6. Remove the motor bell housing mounting bolts [286]. Remove the bell housing [284].
7. Remove the lubricant from the housing.
8. Remove bolts [265] from the lower slow speed cover/flange [266]. Remove bolts from upper slow speed cover [271]. Remove both upper and lower covers from the housing.
9. Remove the slow speed shaft [264] assembly from the housing.
10. Remove the bolts [277] from the high speed cap cover. Remove the high speed cap cover from the housing.
11. Remove the high speed shaft [281] assembly by tapping the motor end toward the high speed cap cover end. Tap with a mallet until the front and rear high speed bearings [280] disengage from their respective bores. Remove retaining ring [273]. *NOTE: The retaining ring must be removed before the high speed shaft [281] and front high speed bearing [280-01] can be removed through the rear high speed bearing bore.*
12. Continue tapping the high speed shaft [281] assembly out of the housing.
13. Remove the high speed seal [287] from the housing.

MIXER MAINTENANCE

14. Remove the two slow speed seals **[261]** from the lower slow speed cover/flange **[266]**. Remove the lower bearing **[267-02]** cup from the cover/flange.
15. Remove the slow speed seal **[261]** from the upper slow speed cover **[271]**. Remove the upper bearing **[267-01]** cup from the cover.
16. Before removing the slow speed shaft bearings, measure and record their positions on the shaft. Use these measurements to correctly position new bearings. Remove the upper and lower bearing **[267]** cones from the shaft.
17. Remove retaining ring **[278]** from the high speed shaft **[281]**. Remove spacer **[275]** and front and rear high speed bearings **[280]**.

The mixer drive is now fully disassembled. Clean parts and inspect for wear. Replace worn parts as required. Remove all gasket material and sealant from mating surfaces.

MIXER MAINTENANCE

Refer to *Figure 2, page 6 and Figure 3, page 7.*

Mixer Assembly

1. Press the front high speed bearing **[280-01]** onto the high speed shaft **[281]** until tight against the shaft shoulder. Position the retaining ring **[273]** onto the high speed shaft before installing the rear high speed bearing **[280-02]**. *NOTE: The retaining ring should be loosely trapped between the high speed shaft bearings.* Press the rear high speed bearing **[280-02]** onto the high speed shaft until tight against the shaft shoulder. Apply press to the bearing inner races only to avoid damaging the bearings. Install the rear high speed bearing spacer **[275]** and retaining ring **[278]**.
2. With the slow speed gear **[269]** and key **[263]** in position on the slow speed shaft **[264]**, press the upper **[267-01]** and lower **[267-02]** bearing cones onto the shaft, to their respective original positions as previously measured, until tight against the gear hub. Apply press to the bearing inner race only, to avoid damaging the bearing. Do not damage the shaft seal surfaces.
3. Install the upper bearing **[267-01]** cup into the upper slow speed cover **[271]**. Apply press until tight against the cover shoulder.
4. Install the lower bearing **[267-02]** cup into the lower slow speed cover/flange **[266]**. Apply press until tight against the cover shoulder.
5. Insert the high speed shaft **[281]** assembly into the rear high speed cap cover **[276]** side of the housing **[270]**. Slide the shaft through until the front high speed bearing **[280-01]** clears the rear retaining ring **[273]** groove in the housing. Install the retaining ring **[273]** into the groove, making sure it is seated properly. Continue inserting the high speed shaft assembly into the housing until the rear high speed bearing **[280-02]** rests against the retaining ring.
6. Install the high speed cap cover **[276]** to the housing using the required thickness of gaskets **[279]** that will take up the clearance between the cap cover and the housing. Tighten bolts **[277]** securely.
7. Insert the slow speed shaft and gear assembly into the housing. Position the gear in mesh with the high speed shaft worm.
8. Install the lower slow speed cover/flange to the housing without gaskets. Tighten bolts **[265]**.

MIXER MAINTENANCE

9. Install the upper slow speed cover [271] to the housing with the proper thickness of gaskets [262] that will provide up to .002" endplay, avoiding bearing pre-load. Tighten bolts [271]. Tap each end of the slow speed shaft with a mallet to seat the bearings before checking the endplay. Once the correct endplay is obtained, remove both covers and re-install with the gaskets equally distributed between the upper and lower covers. Tighten bolts securely. *NOTE: Apply sealant to the bolt threads to prevent leakage.*
10. Install the high speed seal [287] into the front high speed bearing bore, until the seal casing rests against the bearing [280-01]. *NOTE: Apply sealant to the housing bore to prevent leakage.*
11. Install the motor adapter bell housing [284] using gasket [279]. Tighten bolts [286] securely.
12. Install the upper and lower slow speed seals [261] into the covers. *NOTE: Apply sealant to the cover bores to prevent leakage.* Insert the seals with the lip facing the bearings. Fill the cavity between the tandem seals with grease. Use the outer seal to drive in the inner seal.
13. Recheck all fasteners and tighten securely.
14. The housing should require approximately .09 U.S. gallon (.34 liters) of Mobilux SHC629 (or equal) synthetic oil. Refer also to the **Lubrication** section of this manual, page 15. An oil level plug is present on the geardrive. Fill drive until oil just begins to flow from level plug.
15. Clean reducer input shaft [281] and install key [285]. Install reducer flexible coupling half [293] flush with reducer shaft end and setscrew into place. Install motor flexible coupling half [291] flush with shaft end and setscrew into place. Place flexible coupling insert [292] into reducer flexible coupling half.
16. Mount motor [100] to bell housing [284], being careful to line up the flexible coupling insert [292] and the teeth in motor flexible coupling half [291]. Un-cap plug [282] in bell housing for better alignment visibility. Tighten motor mounting bolts [283] to value shown in Table 3, page 14. Replace plug in bell housing.

Do not install the extension shaft at this time. Refer to the **Mounting & Installation** section of the manual for mixer drive installation instructions.

MIXER PART NUMBERS

Part #	Description	Qty.
100	Motor	1
200	Gear Reducer Assembly	
261	Slow Speed Seal	3
262-01	Upper Slow Speed Gasket	1
262-02	Lower Slow Speed Gasket	1
263	Slow Speed Key	1
264	Slow Speed Shaft	1
265	Socket Head Bolts	4
266	Lower Slow Speed Cover/Flange	1
267-01	Upper Bearing – Cup/Cone	1
267-02	Lower Bearing – Cup/Cone	1
268	Pipe Plug	7
269-01	Slow Speed Gear, 5:1 Gear Reduction	1
269-02	Slow Speed Gear, 10:0 Gear Reduction	1
270	Housing	1
271	Upper Slow Speed Cover with Four Bolts	1
272-01	Set Screw	1
272-02	Set Screw	1
273	Retaining Ring	1
275	Spacer	1
276	High Speed Cap Cover	1
277	Hex Bolt	8
278	Retaining Ring	1
279	High Speed Gasket	2
280-01	Front High Speed Bearing	1
280-02	Rear High Speed Bearing	1
281-01	High Speed Shaft, 5:1 Gear Reduction	1
281-02	High Speed Shaft, 10:1 Gear Reduction	1
282	Pipe Plug	1
283	Hex Bolt	4
284	Motor Adapter Bell Housing	1
285	Key	1
286	Hex Bolt	4
287	High Speed Seal	1
288	Shaft Key	1
289	Snap Ring	1
290	Breather	1
291	Grease Fitting	1

MIXER PART NUMBERS

Part #	Description	Qty.
295	Shaft Guard Assembly	
296	Shaft Guard	1
297	Hex Bolt	4
298	Spring Lockwasher	4
299	Flatwasher	4
400	Extension Shaft	1
500	Propellers/Impellers	
	Marine Propeller, Type JP-3	
	High Efficiency Impeller, Type SC-3	



P.O. Box 1123
Dayton, Ohio 45401
Phone: (937) 454-3200
FAX: (937) 454-3375

www.chemineer.com

© Chemineer, Inc. 2004