

# Chemineer XPress Portable Mixers Installation, Operation, Maintenance Manual

Equipment Reference:  
XPB Style Mixer  
XPC Style Mixer

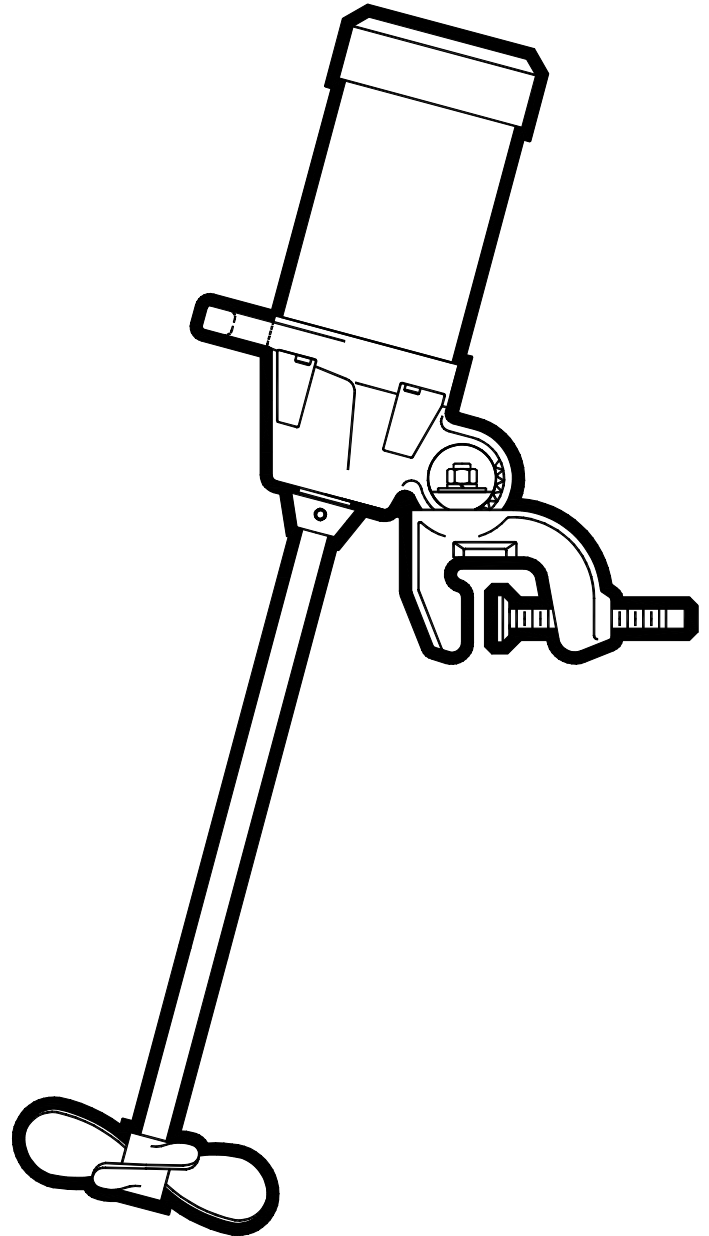

---

**TABLE OF CONTENTS**

<b>Initial Inspection</b>	<b>1</b>
<b>Chemineer Assistance</b>	<b>1</b>
<b>Storage</b>	<b>2</b>
<b>Mounting &amp; Installation</b>	<b>3</b>
10XPB – Bung Mount Mixer Installation .....	3
10XPC, 30XPC, 40XPC – Clamp/Cup Plate Mount Mixer Installation .....	5
Mixer Installation .....	11
<b>Lubrication</b>	<b>16</b>
Electric Motor – Models 10XP, 30XP .....	16
Air Motor – Models 10XP, 30XP .....	18
Gearmotor – Model 40XP .....	18
<b>Operation</b>	<b>19</b>
Mixer .....	19
Electric Motors .....	20
Air Motors .....	20
<b>Maintenance</b>	<b>21</b>
10XPB – Bung Mount Mixer Drive Disassembly .....	21
10XPC – Clamp/Cup Plate Mount Mixer Drive Disassembly .....	21
30XPC/40XPC – Clamp/Cup Plate Mount Mixer Drive Disassembly .....	22
10XPB – Bung Mount Mixer Drive Assembly .....	23
10XPC – Clamp/Cup Plate Mount Mixer Drive Assembly .....	23
30XPC/40XPC – Clamp/Cup Plate Mount Mixer Drive Assembly .....	24
<b>Parts</b>	<b>25</b>

---

## TABLE OF CONTENTS

<b>Tables</b>	<b>Page</b>
<b>Table 1: Bolt Tightening Torque</b> .....	<b>15</b>
<b>Table 2: Motor Bearing Grease Addition</b> .....	<b>16</b>
<b>Table 3: Typical NLGI No. 2 Greases</b> .....	<b>17</b>
<b>Table 4: Lubrication Frequency</b> .....	<b>18</b>

<b>Figures</b>	
<b>Figure 1: Model 10XPB</b> .....	<b>4</b>
<b>Figure 2: Model XPC, Installation</b> .....	<b>7</b>
<b>Figure 3: Model 10XPC</b> .....	<b>8</b>
<b>Figure 4: Model 30XPC</b> .....	<b>9</b>
<b>Figure 5: Model 40XPC</b> .....	<b>10</b>
<b>Figure 6: Wiring Diagram, 1ph Gearmotor</b> .....	<b>12</b>
<b>Figure 7: Wiring Diagram, 3ph Gearmotor</b> .....	<b>13</b>
<b>Figure 8: Wiring Diagram, Motors</b> .....	<b>14</b>

---

## INITIAL INSPECTION

**Step 1: Inspect crates.** Upon receipt, inspect all crates and equipment for shipping damage. Report shipping damage to your local Chemineer office or to the factory in Dayton, Ohio. A claim should be filed immediately with the carrier involved.

**Step 2: Uncrate. Check the contents.** Do not uncrate the unit until you have read the *Mounting & Installation* section of this manual and looked at the assembly drawing shipped with the unit. Be careful in uncrating and handling. Do not discard the crating without making sure that all agitator parts have been removed. Correct assembly of this unit requires referring to both the unit assembly drawing and this manual.

**Step 3: Questions? Call Chemineer.** If the shipment is not complete or you do not understand what you have received, please contact *your local Chemineer office* immediately.

## CHEMINEER ASSISTANCE

Chemineer maintains a fully staffed Parts and Field Service Department ready to help you with any service requirement. Simply contact your local Chemineer office, or contact Parts/Field Service at the Chemineer Factory in Dayton, Ohio:

Chemineer, Inc.  
P.O. Box 1123  
Dayton, Ohio 45401  
Phone: (937) 454-3200  
FAX: (937) 454-3375

Services available are as follows:

Installation and maintenance training seminars,  
Installation and start-up supervision,  
Preventative maintenance planning,  
Parts order service,  
Special instructions.

---

## STORAGE

Do not remove protective packaging or coatings (generally applied to the motor or gearmotor output shafts) until the mixer is to be put into service. If the equipment is to be stored, *do not stack crates*. Store in a clean dry indoor location that is free from wide variations in temperature. The storage area should be free from vibration and excessive heat.

Inspect for external rust at six-month intervals. Apply rust preventative as required. If the unit has been in storage for more than six months or subjected to adverse moisture conditions, the motor windings may have to be dried prior to operation.

### **Short-Term Indoor Storage**

Mixers should be stored indoors in areas with no vibration and relatively constant temperatures and humidity. The factory storage preparations should be acceptable for up to six months storage.

Rotate the drive coupling 10 to 15 revolutions at least once per month to reduce the possibility of brinelling of the bearings and to redistribute bearing grease.

## 10XPB – BUNG MOUNT MIXER INSTALLATION

*Correct unit installation requires both the unit assembly drawing and this manual.*

The 10XPB is a direct drive, bung mounted drum mixer with a 2” NPT connection. The drive unit is typically shipped with the motor [100] mounted to the cast aluminum housing [201-01]. A rigid sleeve coupling [207] should be pre-installed on the motor output shaft. Propellers [500] and all accessories are shipped in the main unit box. Shafting [400] is shipped separately.

*Be certain to locate all contents before discarding packaging materials.*

1. Remove all shipping constraints. A cast aluminum handle is provided to aide in the maneuvering and the positioning of the mixer. This handle is not recommended for use as the primary lifting point for the mixer. A nylon strap, or similar, should be secured around the mixer housing [201-01] to lift and move the mixer. Please note the approximate net weight of the unit as shown on the assembly drawing and use caution when moving or lifting these items.

*At no point during installation or maintenance of the mixer, should the extension shaft ever be used as a lifting point!*

*WARNING: DO NOT connect the mixer to the power source until the unit is fully assembled and properly positioned in the drum vessel.*

2. Install pipe nipple [204] into the 2” NPT drum opening. Refer to *Figure 1, page 4*.
3. Mount the collapsible propeller [500] (setscrew attachment) with the lower hub face even with the shaft end.
4. Assemble the extension shaft [400] to the drive housing assembly [200] by inserting the shaft end with the machined recess into the rigid sleeve coupling [207] 1-1/2” (38mm). Fasten securely by tightening setscrews [203].
5. Insert extension shaft with propeller through drum opening, and turn mixer tightly onto NPT connection.

### 10XPB – BUNG MOUNT MIXER INSTALLATION

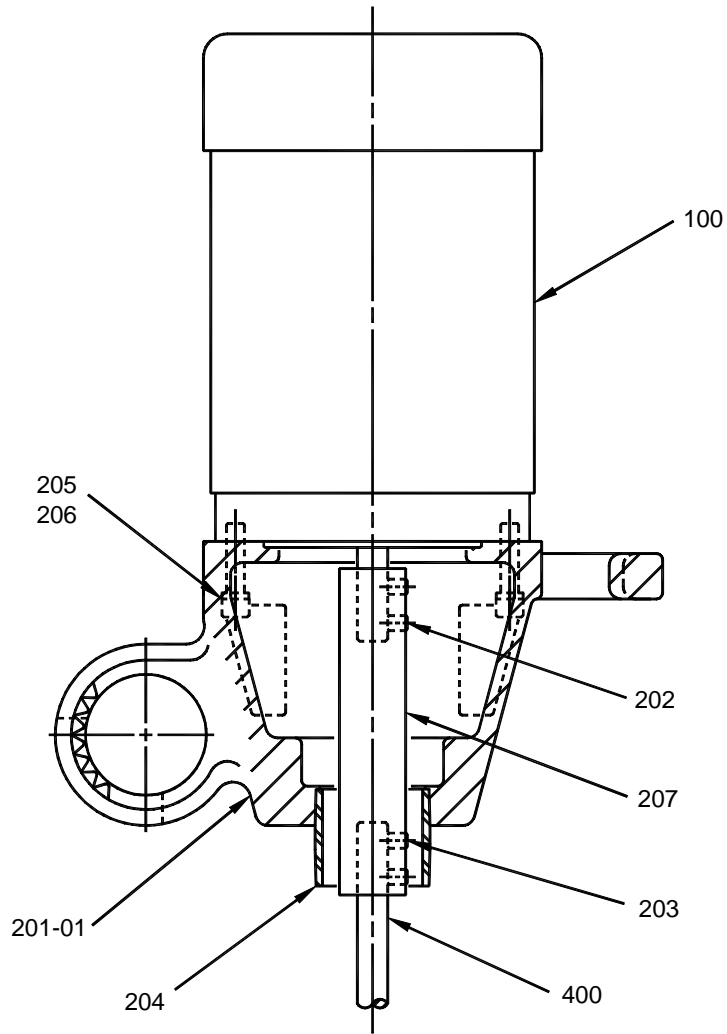

Figure 1: Model 10XPB

## 10XPC, 30XPC, 40XPC – CLAMP/CUP PLATE MOUNT MIXER INSTALLATION

*Correct unit installation requires both the unit assembly drawing and this manual.*

The model 10XPC is a direct drive, clamp or cup plate mount, portable mixer. The drive unit is typically shipped with the motor [100] and standard c-clamp [150] (or optional cup plate [159]) mounted to the cast aluminum housing [201-02]. A rigid sleeve coupling [207] should be installed on the motor output shaft. Propellers [500] and all accessories are shipped in the main unit box. Shafting [400] is shipped separately. Refer to *Figure 3, page 8*.

The model 30XPC is a direct drive, clamp or cup plate mount, portable mixer. The drive unit is typically shipped with the motor [100] and standard c-clamp [150] (or optional cup plate [159]) mounted to the cast aluminum housing [201-02]. A plated chuck drive shaft [214] coupling with bearing support extends from the housing for extension shaft attachment. Propellers [500] and all accessories are shipped in the main unit box. Shafting [400] is shipped separately. Refer to *Figure 4, page 9*.

The model 40XPC is a gear reduced, clamp or cup plate mount, portable mixer. The drive unit is typically shipped with the gearmotor (integral motor/gear reducer) [105] and standard c-clamp [150] (or optional cup plate [159]) mounted to the cast aluminum housing [201-02]. A plated chuck drive shaft [214] coupling with bearing support extends from the housing for extension shaft attachment. Propellers or impellers [500] and all accessories are shipped in the main unit box. Shafting [400] is shipped separately. Refer to *Figure 5, page 10*.

*Be certain to locate all contents before discarding packaging materials.*

1. Remove all shipping constraints. A cast aluminum handle is provided to aide in the maneuvering and the positioning of the mixer. This handle is not recommended for use as the primary lifting point for the mixer. A nylon strap, or similar, should be secured around the mixer housing assembly [201-02] to lift and move the mixer. Please note the approximate net weight of the unit as shown on the assembly drawing and use caution when moving or lifting these items. *At no point during installation or maintenance of the mixer, should the extension shaft ever be used as a lifting point!*

*WARNING: DO NOT connect the mixer to the power source until the unit is fully assembled and properly positioned on the vessel.*

2. Install the mixer drive assembly on the tank edge or other suitable support by means of the c-clamp [150] or cup plate [159] mounting. Support structure must be rigid enough to prevent deflection and vibration and clean from debris.

*The mixer should never be mounted with the shaft and propeller(s) installed.*

3. Clamp mounted units should be set squarely on the mounting surface with the actual clamped surfaces contacting as much as possible.



**10XPC, 30XPC, 40XPC – CLAMP/CUP PLATE MOUNT MIXER INSTALLATION**

4. The unit is shipped with the clamp **[150]** or cup plate **[159]** bolted to the housing. This connection is generally “loosely” bolted and will require tightening in the following installation order:
  - a. For clamp **[150]** mounted units, lubricate the clamp bolt **[151]** and initially torque to 18 ft-lb (24.4 Nm). The clamp bolt should be tight enough to keep the unit located on the tank. For cup plate **[159]** mounted units, attach plate to mounting surface.
  - b. After orientation of mixer is determined (reference *Figure 2, page 7*), torque hex nut **[155]** in the socket area to 50 ft-lb (67.8 Nm).
  - c. For clamp mounted units, final torque the clamp bolt **[151]** to 36 ft-lb (48.8 Nm).
5. For 10XPC units, assemble the extension shaft **[400]** to the drive housing assembly **[200]** by inserting the shaft end with the machined recess into the rigid sleeve coupling **[207]** 1-1/2” (38mm). Tighten sleeve setscrews **[203]** with a 5/32” hex key wrench.
6. For 30XPC or 40XPC units, assemble the extension shaft **[400]** to the drive housing assembly **[200]** by inserting the shaft end with the machined recess and “flats” into the chuck coupling until the shaft bottoms out, approximately 5” (127mm). Orient the shaft to allow the chuck coupling setscrews **[213]** (two at 90°) to engage the “flats”. Refer to *Figure 4, page 9 and Figure 5, page 10*. Tighten chuck setscrews **[213]** with a 3/16” hex key wrench.
7. For single propeller assemblies, install the propeller with the lower hub face even with the shaft end. Propeller orientation should allow the driving edge of the propeller to pump toward the bottom of the mixing vessel. Tighten the propeller setscrews (typically quantity two).

For dual propeller assemblies, space the upper propeller at a recommended minimum of two propeller diameters and maximum of three propeller diameters above the lower propeller. The lower propeller should be a minimum of one propeller diameter below the liquid surface at all times during mixer operation.

**10XPC, 30XPC, 40XPC – CLAMP/CUP PLATE MOUNT MIXER INSTALLATION**

8. In operation, some adjustments of position may be required to obtain best mixing results. Adjust orientation of mixer as shown in *Figure 2, below* for best top to bottom flow and optimum mixing efficiency. Both the clamp and cup plate mount assemblies provide for 3-dimensional adjustment.

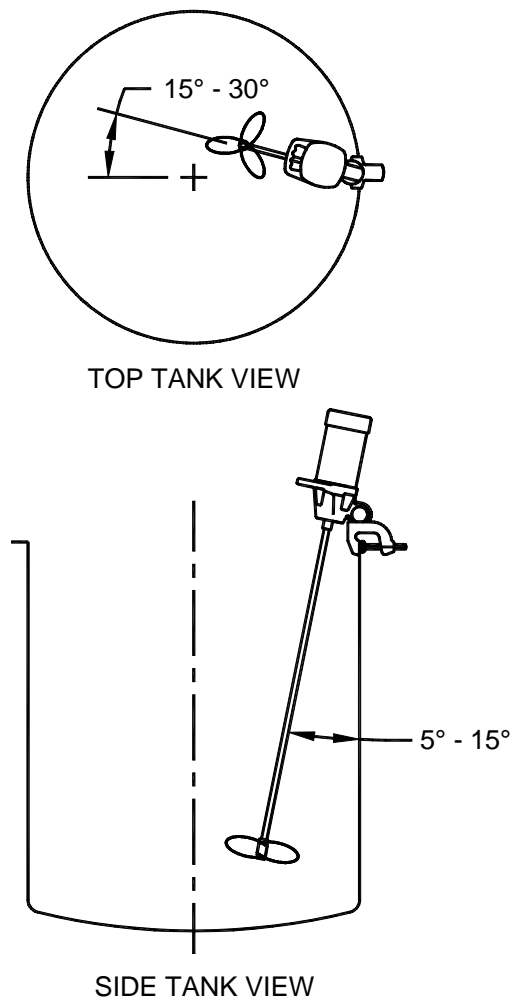

Figure 2: Model XPC, Installation

10XPC – CLAMP/CUP PLATE MOUNT MIXER INSTALLATION

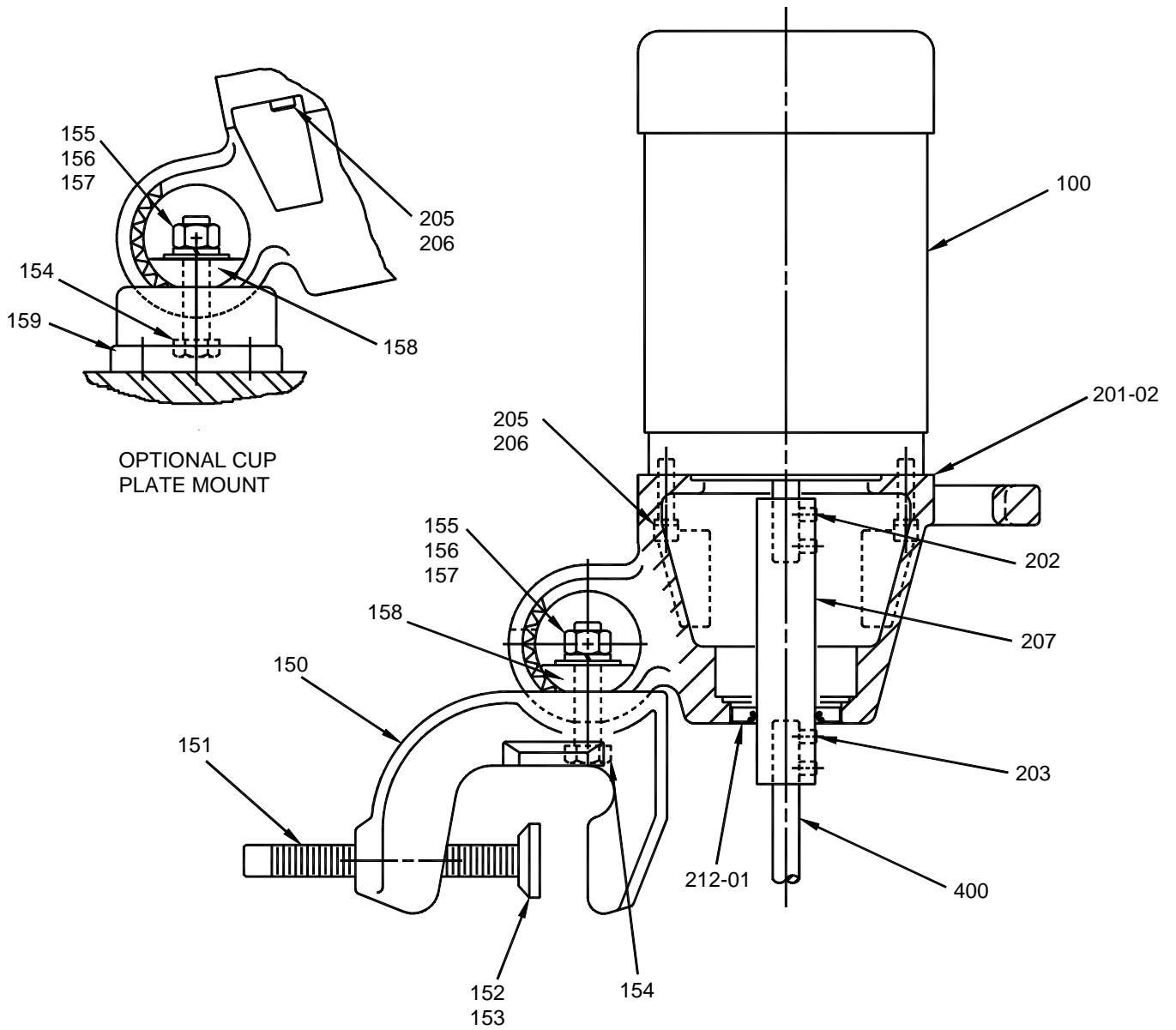

Figure 3: Model 10XPC

### 30XPC – CLAMP/CUP PLATE MOUNT MIXER INSTALLATION

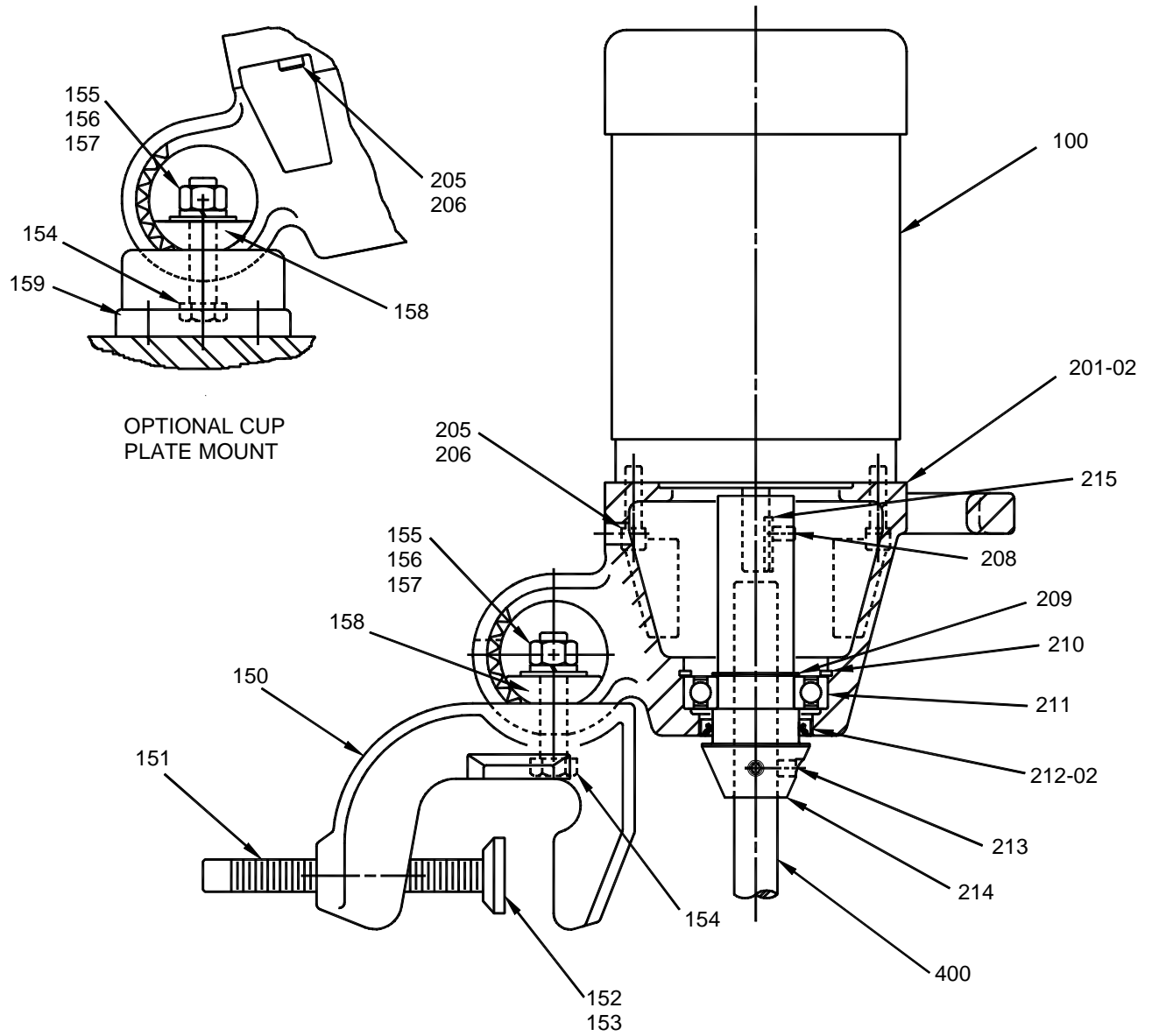

Figure 4: Model 30XPC

### 40XPC – CLAMP/CUP PLATE MOUNT MIXER INSTALLATION

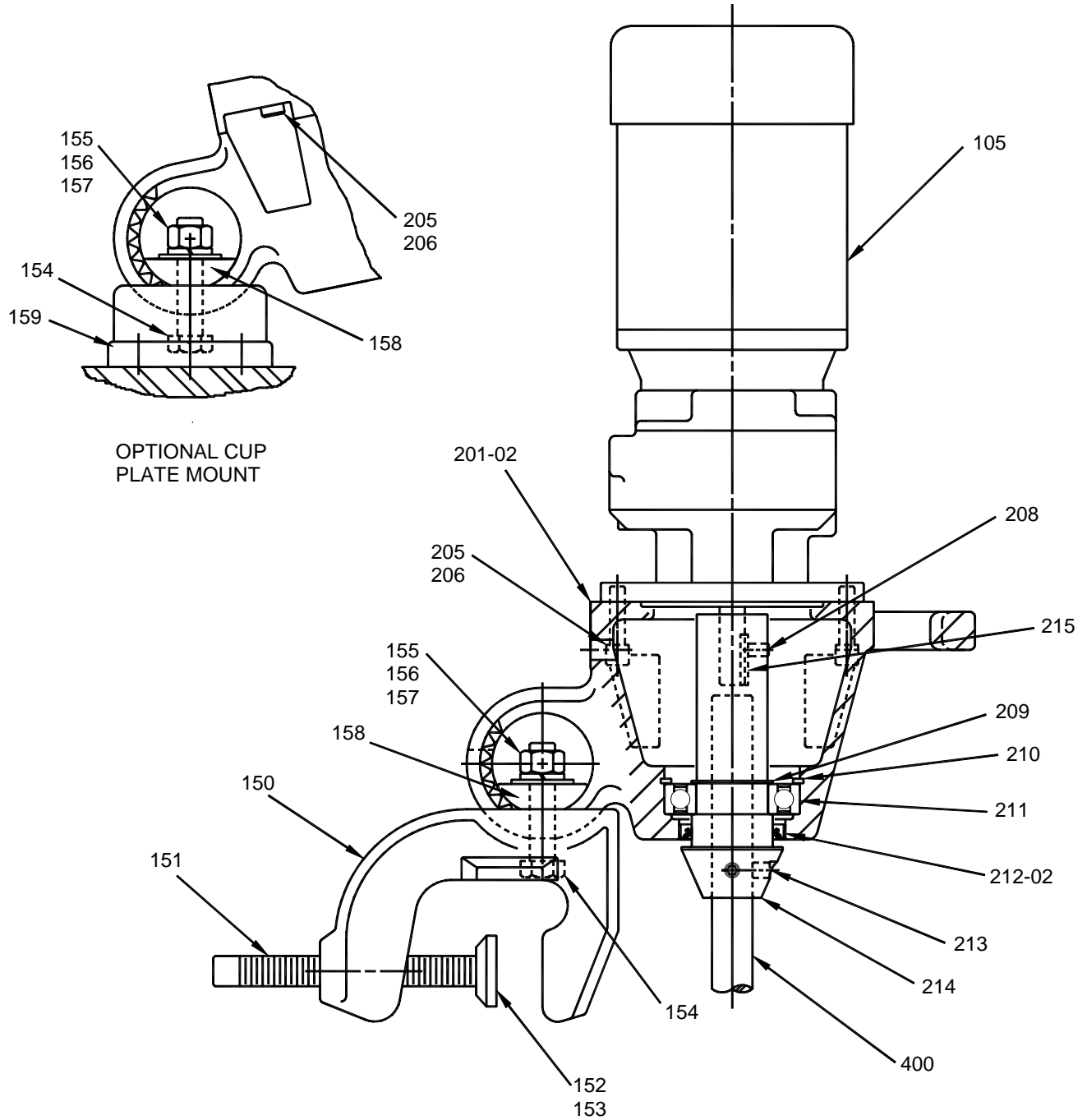

Figure 5: Model 40XPC

## MIXER INSTALLATION ELECTRIC MOTORS, GEARMOTORS

1. Check the nameplate data on the motor/gearmotor to assure that the available power supply agrees with the motor requirements. Protective devices should be of the proper size and rating to safely carry the load and interrupt the circuit on overloads.
2. If the motor/gearmotor has been stored in a damp location, the windings may require drying.

*NOTE: Do not obstruct the normal flow of ventilating air through or over the motor/gearmotor.*

3. Many of the motors supplied with this product are dual voltage. The motor cord supplied with a single phase motor is applicable for use on 125VAC systems only. Customer is responsible for supplying all necessary motor connections and for properly wiring the motors. Refer to wiring diagrams *Figures 6 and 7, pages 12 and 13*, for gearmotor connections and *Figure 8, page 14* for normal motor connections. Consult *Chemineer Field Service* if there are any questions pertaining to the installation or operation of the motor or mixer unit.
4. Connect the motor/gearmotor in accordance with the National Electric Code and local requirements, but do not make the connections permanent until the motor/gearmotor rotation has been checked. Jog the motor/gearmotor to check for correct rotation prior to securing wiring. Refer to unit assembly drawing for unit rotation direction.
5. If any additional motor/gearmotor auxiliary devices such as space heaters or temperature sensors are used, connect them in proper circuits and insulate them from motor/gearmotor power cables.

## AIR MOTORS

1. Air motors are designed to be driven by compressed air. Under no circumstances should they be driven with any other type of gas, fluids, particles, solids, or any substance mixed with air. The muffler is shipped uninstalled on the air motor. Always install a moisture trap and filter in the air line ahead of the motor.
2. “Reversible” type air motors will work equally in both directions. A 4-way valve may be connected to both air ports to allow reversible operation. For efficiency of output and control of speed, use air lines of the same size or the next larger pipe size than the intake port of the motor.
3. *Lubrication of the air motor is required.* Refer to **Lubrication** section of this manual for more information.

**MIXER INSTALLATION**

TYPE EAR (CAPACITOR START & RUN)

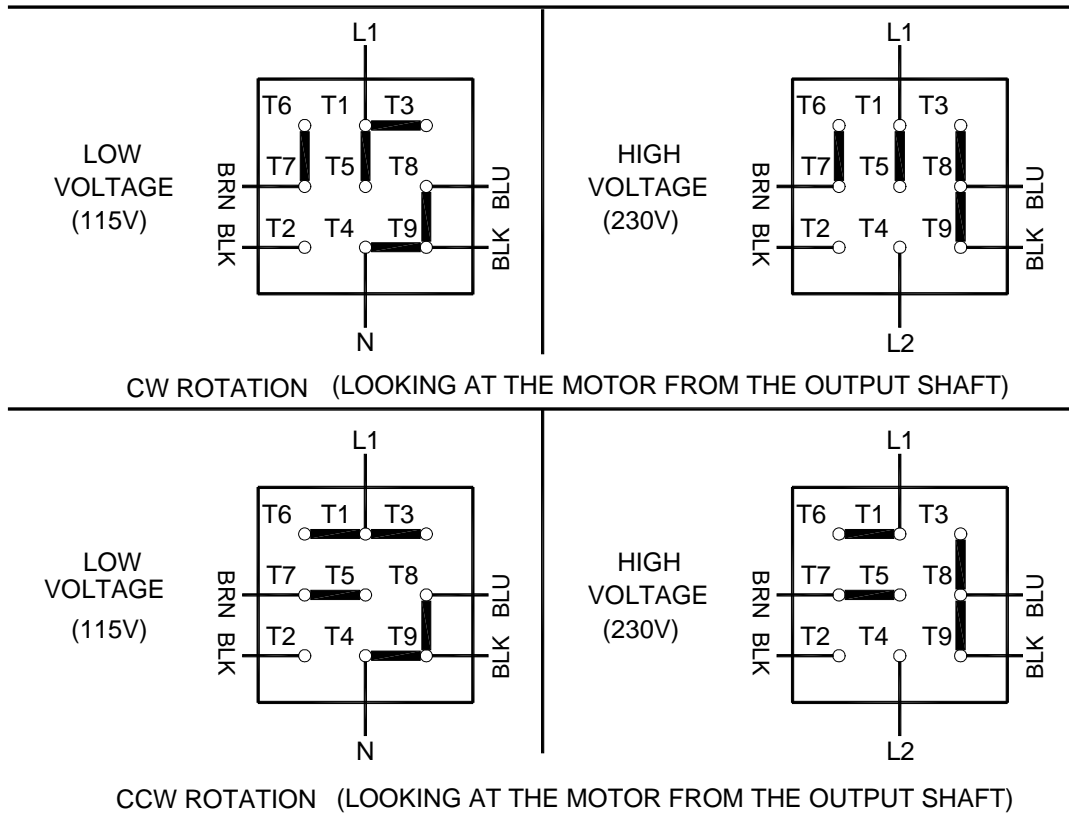
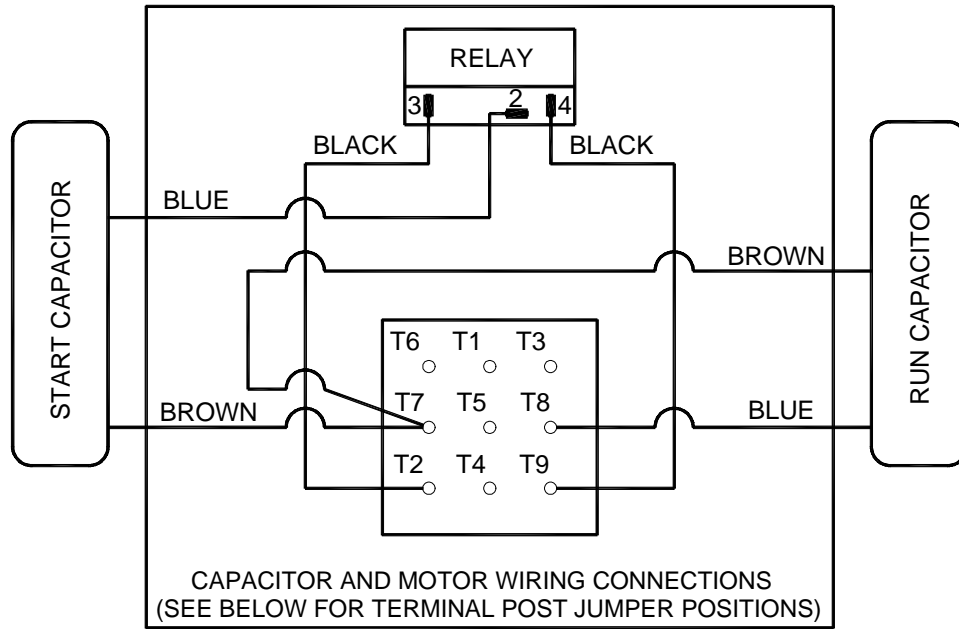
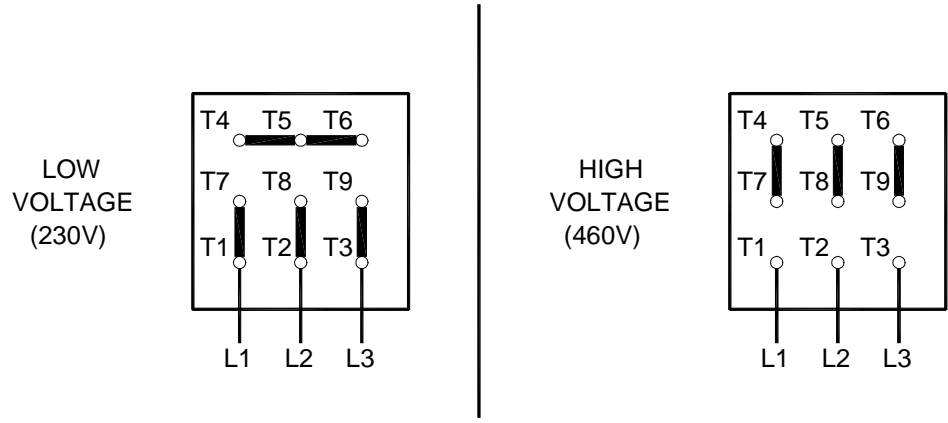

Figure 6: Wiring Diagram, 1ph Gearmotor

**MIXER INSTALLATION**

MOTOR WIRING CONNECTIONS AND  
TERMINAL POST JUMPER POSITIONS



NOTE: TO REVERSE GEARMOTOR SHAFT ROTATION,  
INTERCHANGE ANY TWO LINE LEADS

CHECK MOTOR LEADS WITH CONNECTION DIAGRAMS ON MOTOR  
NAMEPLATE OR CONDUIT BOX FOR PROPER WIRING

CHECK THE MIXER SHAFT ROTATION AGAINST THE PROPER  
ROTATION INDICATED ON THE ASSEMBLY DRAWING

NOTE:  
THE NORMAL GEARMOTOR OUTPUT SHAFT ROTATION SHOULD BE CCW  
WHEN LOOKING AT THE GEARMOTOR FROM THE OUTPUT SHAFT END.  
THE NORMAL MIXER SHAFT ROTATION IS CW WHEN LOOKING INTO THE  
TANK FOR STANDARD ROTATION IMPELLERS.

Figure 7: Wiring Diagram, 3ph Gearmotor



**MIXER INSTALLATION**

**SINGLE-PHASE MOTOR  
(WITHOUT THERMAL PROTECTOR)**

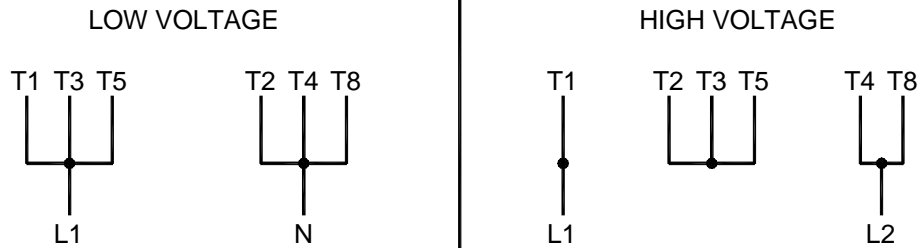

CCW ROTATION (LOOKING AT THE MOTOR FROM THE SHAFT END)

NOTE: TO REVERSE MOTOR SHAFT ROTATION,  
INTERCHANGE MOTOR LEADS T5 AND T8

**THREE-PHASE MOTOR  
(WITHOUT THERMAL PROTECTOR)**

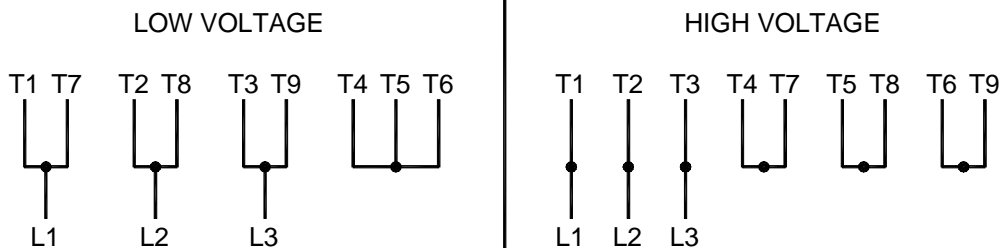

NOTE: TO REVERSE MOTOR SHAFT ROTATION,  
INTERCHANGE ANY TWO LINE LEADS

CHECK MOTOR LEADS WITH CONNECTION DIAGRAMS ON MOTOR  
NAMEPLATE OR CONDUIT BOX FOR PROPER WIRING

CHECK THE MIXER SHAFT ROTATION AGAINST THE PROPER  
ROTATION INDICATED ON THE ASSEMBLY DRAWING

NOTE:  
THE NORMAL MOTOR SHAFT ROTATION SHOULD BE CCW WHEN  
LOOKING AT THE MOTOR FROM THE SHAFT END.  
THE NORMAL MIXER SHAFT ROTATION IS CW WHEN LOOKING INTO THE  
TANK FOR STANDARD ROTATION IMPELLERS.

Figure 8: Wiring Diagram, Motors

**MIXER INSTALLATION****TABLE 1: BOLT TIGHTENING TORQUE**

BOLT SIZE	CARBON STEEL <sup>(1)</sup>				300 SERIES STAINLESS <sup>(2)</sup>	
	GRADE 2		GRADE 5		Ft-lb	Nm
	Ft-lb	Nm	Ft-lb	Nm		
1/4-20	4.1	5.6	6	8.1	4.1	5.6
5/16-18	8.3	11	13	17	8.3	11
3/8-16	15	20	23	31	15	20
1/2-13	38	51	56	76	38	51
5/8-11	68	92	113	153	68	92
3/4-10	120	163	200	271	120	163

Tighten all fasteners to values shown unless specifically instructed to do otherwise. Lubricate all fasteners at assembly with grease, oil or an anti-seize material. Bolt threads and contact surfaces of bolt heads and nuts should be lubricated.

<sup>(1)</sup>If fasteners cannot be lubricated, multiply table values by 1.33.

<sup>(2)</sup>If fasteners cannot be lubricated, multiply table values by 1.25.

## LUBRICATION

This section defines the proper oils and greases that must be used with this equipment.

### ELECTRIC MOTOR – MODELS 10XP, 30XP

The motor bearings have been properly greased by the manufacturer. Motor bearings should be regreased at 12-month intervals when installed in clean, dry environments, or every six months for heavy duty and dusty locations. Any good quality general purpose grease consisting of a refined base oil stock and a lithium or calcium-complex based soap, with an NLGI No. 2 classification, will work satisfactorily. Most major oil companies offer such products, usually with extreme pressure (EP) additives for additional protection. *Table 3, page 17* lists some commonly available greases.

When regreasing, stop the motor, remove the outlet plug and add grease according to *Table 2* with a hand lever gun only. Run the motor for about ten minutes before replacing the outlet plug. Certain TEFC motors have a spring relief outlet fitting on the fan end. If the outlet plug is not accessible at the surface of the hood, it is the spring relief type and need not be removed when regreasing.

*CAUTION! Overgreasing is a major cause of bearing and motor failure.*

**TABLE 2: MOTOR BEARING GREASE ADDITION**

MOTOR FRAME SIZE	RELIANCE		LEESON		BALDOR	
	in <sup>3</sup>	cm <sup>3</sup>	in <sup>3</sup>	cm <sup>3</sup>	in <sup>3</sup>	cm <sup>3</sup>
56C	sealed for life		sealed for life		sealed for life	
140TC	sealed for life		sealed for life		0.6	9.8

**ELECTRIC MOTOR – MODELS 10XP, 30XP****TABLE 3: TYPICAL NLGI NO. 2 GREASES**

<i>For Ambient Temperature Range of 0° to 104° F (-18° to 40° C)</i>		
<b>MANUFACTURER</b>	<b>GENERAL PURPOSE</b>	<b>EP</b>
Amoco Oil Co.	Amolith grease: Grade 2	Amolith grease: Grade 2EP
Ashland Oil Co.		Multi-lube Lithium EP grease: Grade 2
		EP Lithium #2
Chevron U.S.A.Inc.	Industrial grease: Grade medium	Dura-Lith greases EP: Grade 2
CITGO Petroleum Corp.		Premium Lithium EP grease: Grade 2
Conoco Inc.		EP Conolith grease: Grade 2
Exxon Co. U.S.A.	Unirex N: Grade 2	Nebula EP: Grade 2
		Ronex MP: Grade 2
Mobil Oil Corp.		Mobilux EP 2
Pennzoil Products Co.		Pennlith EP grease 712
Phillips 66 Co.	Philube L Multi-purpose grease L-2	Philube EP grease: EP-2
Shell Oil Co.	Alvania grease 2	Alvania grease EP 2
		Alvania grease EP LF 2
Texaco Lubricants Co.	Premium RB grease	Multifak EP 2
Unocal 76		Unoba EP grease: Grade 2
		Multiplex EP: Grade 2

### ELECTRIC MOTOR – MODELS 10XP, 30XP

The following table may be used as a guide in determining frequency of lubrication. The periods listed assume a clean, dry environment with an ambient temperature not exceeding 104°F (40°C). If conditions are less desirable than this, adjust the frequency accordingly. (*Table 4* is for motor speeds 1800 RPM or slower).

**TABLE 4: LUBRICATION FREQUENCY**

DUTY	LUBRICATION INTERVAL (Months)
Intermittent	36
8-16 Hours/Day	30
Continuous	24

### AIR MOTOR – MODELS 10XP, 30XP

*Lubrication of the air motor is required.* An automatic air line lubricator must be installed in the air line just ahead of the air motor. The lubricator should be adjusted to feed one drop of oil for every 50-75 CFM of air going through the motor. Detergent SAE #10 automotive engine oil or equivalent is the recommended air motor lubricant.

### GEARMOTOR – MODEL 40XP

The gearmotor (gear reducer) has been permanently lubricated with mineral oil, ISO 220 grade, acceptable for operation in ambient temperatures not exceeding 104°F (40°C). The gearmotor can be operated at up to a 10 degree off vertical mounting angle, any orientation.

## MIXER

Proper operating procedures will allow maximum performance of your Chemineer XPress Portable Mixer. The following list will aid in the safe operation of your unit.

- **Do not** operate the unit before reading and following the instructions on all tags and nameplates attached to the unit.
- **Do not** operate the unit with less than one propeller's diameter liquid coverage above the lowest propeller. Increased side loading caused by operations at liquid level will decrease unit life.
- **Do not** operate the unit in a fluid with a specific gravity or viscosity higher than that for which the unit was designed.
- **Do not** attempt to start the unit with the mixing propeller buried in solids or a "set up" fluid.
- **Do not** locate tank internals or other rotating equipment close to the mixer propellers or extension shaft.
- **Do not** make any modifications to the mixer unit in the field (i.e. motor horsepower, mixer speed, shaft length, impeller diameter, etc.) without reviewing the change with *your local Chemineer office or Chemineer Field Service.*

**CAUTION:** There may be a speed range where the unit cannot be operated because of shaft resonant frequency. This range must be avoided or passed through quickly or destructive forces can be generated. Refer to the main unit assembly drawing for speed range information or consult *your local Chemineer office.*

Should there be problems operating the unit, confirm that the installation is correct. If you are unable to resolve the problem, contact *your local Chemineer office.*

## ELECTRIC MOTORS

Air circulation is very important to get full performance and long life from an electric motor. Do not block the suction inlets on fan-cooled motors. Motor life will be decreased if its temperature exceeds its thermal rating. The allowable temperature is stamped on the motor nameplate.

Prior to permanently wiring the electric motor:

- Check nameplate data on motor to assure that the available power supply agrees with the motor requirements. Protective devices should be the proper size and rating to safely carry the load and to interrupt the circuit on overloads.
- Check motor leads with connection diagrams on motor nameplate and/or conduit box so that the proper connections are made. All motors should be installed in accordance with the National Electric Code and local requirements.
- Check the output shaft rotation against the proper rotation indicated on the assembly drawing. For standard three-phase electric motors, the rotation is reversed by switching any two power leads.
- Check operating motor amperage against nameplate amperage.

The motor should start quickly and run smoothly. If the motor should fail to start or make abnormal noise, immediately shut motor off, disconnect it from the power supply, and investigate the cause. If the problem cannot be corrected, contact *your local Chemineer office* for assistance.

## AIR MOTORS

Air motors are designed to be driven by compressed air. Under no circumstances should they be driven with any other type of gas, fluids, particles, solids, or any substance mixed with air.

Operating pressures should not exceed 100psi (689 kPa). The speed and torque can be regulated by using a pressure regulator or shut-off valve to obtain the desired power and conserve air.

## MIXER MAINTENANCE

### *Mixer Removal & Disassembly*

*CAUTION: Prior to removing mixer, review the installation to assure that all safety issues are resolved.*

1. Lock out and disconnect all power to the mixer motor and any optional devices.
2. Remove the extension shaft **[400]**, models 10XPC, 30XPC and 40XPC only.
3. Remove the mixer drive unit from the tank and move to a suitable service area. For model 10XPB, turn (un-screw) the drive assembly off of the NPT connection and lift entire unit including shaft from tank.

### *10XPB – Bung Mount Mixer Drive Disassembly*

Refer to *Figure 1, page 4*.

- a. Remove the extension shaft **[400]**.
- b. Remove the motor mounting bolts **[205]**. Remove the motor **[100]** and sleeve coupling **[207]** assembly from the housing **[201-01]**.
- c. Remove the sleeve coupling from the motor output shaft by loosening the setscrews **[202]**.

### *10XPC – Clamp/Cup Plate Mount Mixer Drive Disassembly*

Refer to *Figure 3, page 8*.

- a. Remove the motor mounting bolts **[205]**. Remove the motor **[100]** and sleeve coupling **[207]** assembly from the housing **[201-02]**.
- b. Remove the sleeve coupling from the motor output shaft by loosening the setscrews **[202]**.
- c. Remove the lip seal **[212-01]** from the housing.



## MIXER MAINTENANCE

### 30XPC/40XPC – Clamp/Cup Plate Mount Mixer Drive Disassembly

Refer to *Figures 4 & 5, pages 9 & 10.*

- a. Rotate the chuck drive shaft **[214]** until the motor shaft setscrew **[208]** is aligned with the setscrew access hole located in the housing **[201-02]**. Insert a 3/16" hex key wrench into the access hole and engage the setscrew. Loosen the setscrew.
- b. Remove the motor mounting bolts **[205]**. Remove the motor **[100]** or gearmotor **[105]** from the housing **[201-02]**.
- c. Remove the motor shaft setscrew **[208]**. Remove the snap ring **[209]** from the chuck drive shaft **[214]**.
- d. Mount the housing, motor mounting end up, in an arbor press. Press the chuck drive shaft out of the housing.
- e. Remove the snap ring **[210]** from the housing.
- f. Turn the housing over, motor mounting end down, and remove the lip seal **[212-02]**.
- g. Press the bearing **[211]** out of the housing.

#### ***Applicable to all units:***

*The mixer drive is now fully disassembled. Clean parts and inspect for wear. Replace worn parts as required.*

## MIXER MAINTENANCE

### *Mixer Assembly*

#### **10XPB – Bung Mount Mixer Drive Assembly**

Refer to *Figure 1, page 4*.

1. Install the sleeve coupling [207] onto the motor shaft [100]. Tighten setscrews [202] securely.
2. Install the motor and sleeve coupling assembly into the housing [201-01].
3. Install the motor mounting bolts [205] and hi-collar lockwashers [206]. Tighten bolts securely.

Do not install the extension shaft at this time. Refer to the **Mounting & Installation** section of the manual for mixer drive installation instructions.

#### **10XPC – Clamp/Cup Plate Mount Mixer Drive Assembly**

Refer to *Figure 3, page 8*.

1. Install the sleeve coupling [207] onto the motor shaft [100]. Tighten setscrews [202] securely.
2. Install the lipseal [212-01] into the housing (seal lip facing inward, flush with the bottom of the housing).
3. Apply grease to the lip of the lip seal.
4. Install the motor and sleeve coupling into the housing [201-02]. *NOTE: Make sure that the sleeve coupling extension shaft setscrews [203] do not damage the lip seal [212-01].*
5. Install the motor mounting bolts [205] and hi-collar lockwashers [206]. Tighten bolts securely.

Do not install the extension shaft at this time. Refer to the **Mounting & Installation** section of the manual for mixer drive installation instructions.

## MIXER MAINTENANCE

### 30XPC/40XPC – Clamp/Cup Plate Mount Mixer Drive Assembly

Refer to *Figures 4 & 5, pages 9 & 10.*

1. Mount the housing **[201-02]**, motor mounting end up, in an arbor press. Press the bearing **[211]** into the housing, to the shoulder of the housing bearing bore. *NOTE: Apply press to the outer bearing race only, to avoid damaging the bearing.*
2. Install the snap ring **[210]** into the housing bearing bore.
3. Turn the housing over, motor mounting end down. Install the lip seal **[212-02]** into the housing (seal lip facing the bearing, flush with the bottom of the housing).
4. Support the housing, motor mounting end down, by resting the inner race of the bearing **[211]** on a suitable pipe or tube fixture. *NOTE: The inner bearing race must be supported while installing the chuck drive shaft **[214]** to avoid damaging the bearing.*
5. Apply grease to the lip of the lip seal **[212-02]**.
6. Press the chuck drive shaft **[214]** into the bearing **[211]**, to the shoulder of the shaft.
7. Install snap ring **[209]** onto chuck drive shaft.
8. Install the motor shaft setscrew **[208]**.
9. Install the motor or gearmotor key **[215]** onto the motor shaft using Loctite Adhesive.
10. Align the motor shaft key and the chuck drive shaft keyway, and install the motor or gearmotor onto the housing.
11. Install the motor mounting bolts **[205]** and hi-collar lockwashers **[206]**. Tighten bolts securely.
12. Rotate the chuck drive shaft **[214]** until the motor shaft setscrew **[208]** is aligned with the setscrew access hole located in the housing **[201-02]**. Insert a 3/16" hex key wrench into the access hole and engage the setscrew. Tighten the setscrew securely.

Do not install the extension shaft at this time. Refer to the **Mounting & Installation** section of the manual for mixer drive installation instructions.

**XPRESS PORTABLE MIXER PART NUMBERS**

Part #	Description	Qty.
100	Motor	1
105	Gearmotor	1
150	C-Clamp	1
151	Clamp Bolt	1
152	Clamp Pad	1
153	Pad Retainer	1
154	Hex Bolt	1
155	Hex Nut	1
156	Spring Lockwasher	1
157	Flatwasher	1
158	Lock Shoe	1
159	Cup Plate	1
200	Housing Assembly	
201-01	Housing, Model 10XPB	1
201-02	Housing, Models 10XPC, 30XPC, 40XPC	1
202	Setscrew, Motor Output Shaft/Sleeve Coupling	2
203	Setscrew, Extension Shaft/Sleeve Coupling	2
204	Pipe Nipple, 2" NPT Connection	1
205	Socket Head Bolt	4
206	Hi-Collar Lockwasher	4
207	Sleeve Coupling	1
208	Setscrew, Motor Output Shaft/Chuck Coupling	1
209	Snap Ring	1
210	Snap Ring	1
211	Bearing	1
212-01	Lip Seal	1
212-02	Lip Seal	1
213	Setscrew, Extension Shaft/Chuck	2
214-01	Chuck Drive Shaft, Mate 56C to 1" Shaft	1
214-02	Chuck Drive Shaft, Mate 140TC to 1" Shaft	1
215-01	Motor Key, 56C Motor	1
215-02	Motor Key, 140TC Motor	1
400	Extension Shaft	1
500	Propellers/Impellers	
	Collapsible Propeller	
	Dispersion Blade Impeller	
	Marine Propeller, Type JP-3	
	High Efficiency Impeller, Type SC-3	