



Pipex Offsite Build Civil Engineered Chambers

Our Pipex offsite build civil engineered chambers are manufactured from advanced polypropylene or high-density polyethylene thermoplastic material and provide a corrosion resistant, fully sealed, fluid and gas tight alternative to traditional concrete and brick chambers.

Our chambers are designed to handle surface water and foul water surcharges during peak flow storm events in public drains and sewers, and are currently installed by 8 of the 10 largest water companies in the UK.

We can build circular or rectangular chambers manufactured to BS EN12573 complete with optional internal equipment including safety handrails, access ladders to flow control devices, and static/mechanical screens. In addition, we can add integral steel rebar and timber shuttering to accept site poured concrete surround with minimal concrete waste.

Key Advantages:

- Manufactured from advanced thermoplastic materials that are corrosion resistant, versatile and robust
- Lightweight - typically $\frac{1}{3}$ the weight of traditional materials
- Low electrical and thermal conductivity properties
- Guaranteed fluid and gas tight dependent on client specifications
- Optional specifications such as shuttering/rebar available
- Delivered to site in prefabricated units minimising installation schedules
- Cost effective solutions
- Up to 60-year design life dependant on application
- Cable and pipe connections will be configured to suit existing system design drawings
- Chambers designed to suit project specifications
- All internal equipment can be installed prior to delivery and onsite install

Offsite Build Civil Engineered Chambers

Civil Engineered Chamber Features

- Circular or rectangular chambers manufactured to BS EN12573 in reinforced self-cleansing, hygienic HDPE materials that minimise risk of leaks, blockages and FOG accumulation
- Access steps factory installed BS EN131:2002
- Cable Ducts position to suit
- Jet wash and spray systems can be installed within factory for external connection
- Lifting lugs for chamber offloading
- Optional integral temporary shuttering to accept site poured concrete surround with minimal concrete waste
- Optional integral rebar mesh reinforcement
- Full welded, sealed and integral pre-formed benching, channels and pipe work swept in direction of flow
- Adjustable weir walls
- Supplied with any make or model of static, rotational or mechanical screens as specified by designers/client
- Supplied with any make or model of flow control device as specified by designers/client
- Bespoke pipe connections and couplings
- Dimensions and configurations of chambers 100% bespoke to suit design requirements
- Inlet and outlet pipework diameter and configuration to suit
- Optional integral penstock valves
- Open top chamber for interface with structural slabs or optional integral top form to accept in-situ poured concrete cover slab
- Integral rib reinforcement provides structural strength for loading and prevent floatation and external groundwater pressure

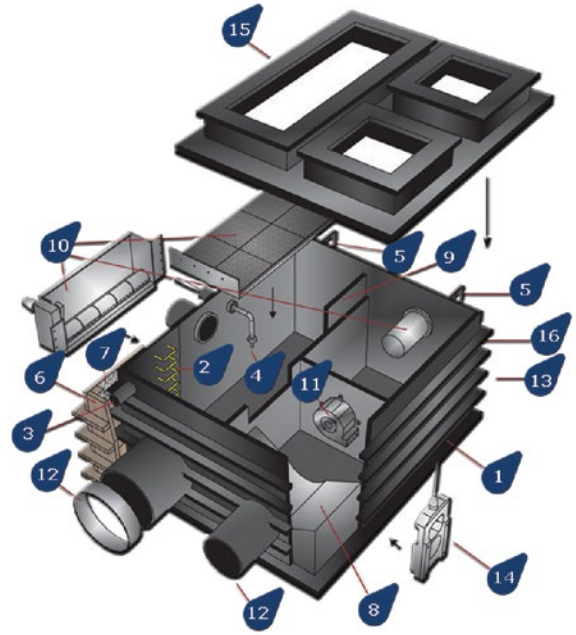

Factory fitted rebar reinforcement and shuttering

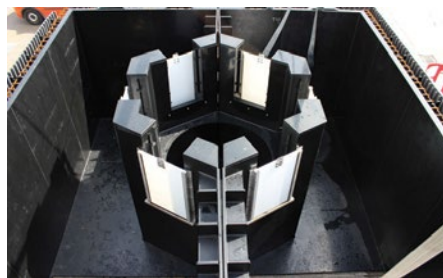

Bespoke designs to suit project requirements

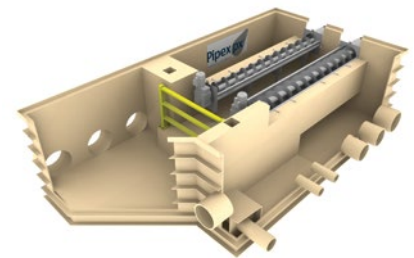

BIM model of civil engineered chambers



Chamber with optional flow control activated penstock and walkway cover or odour control cover



Our modular chambers are lightweight and fast to install



Factory installed equipment such as screens, baffles with benching and weir walls to suit project specific designs complete with optional access ladders & rebar