

Mining

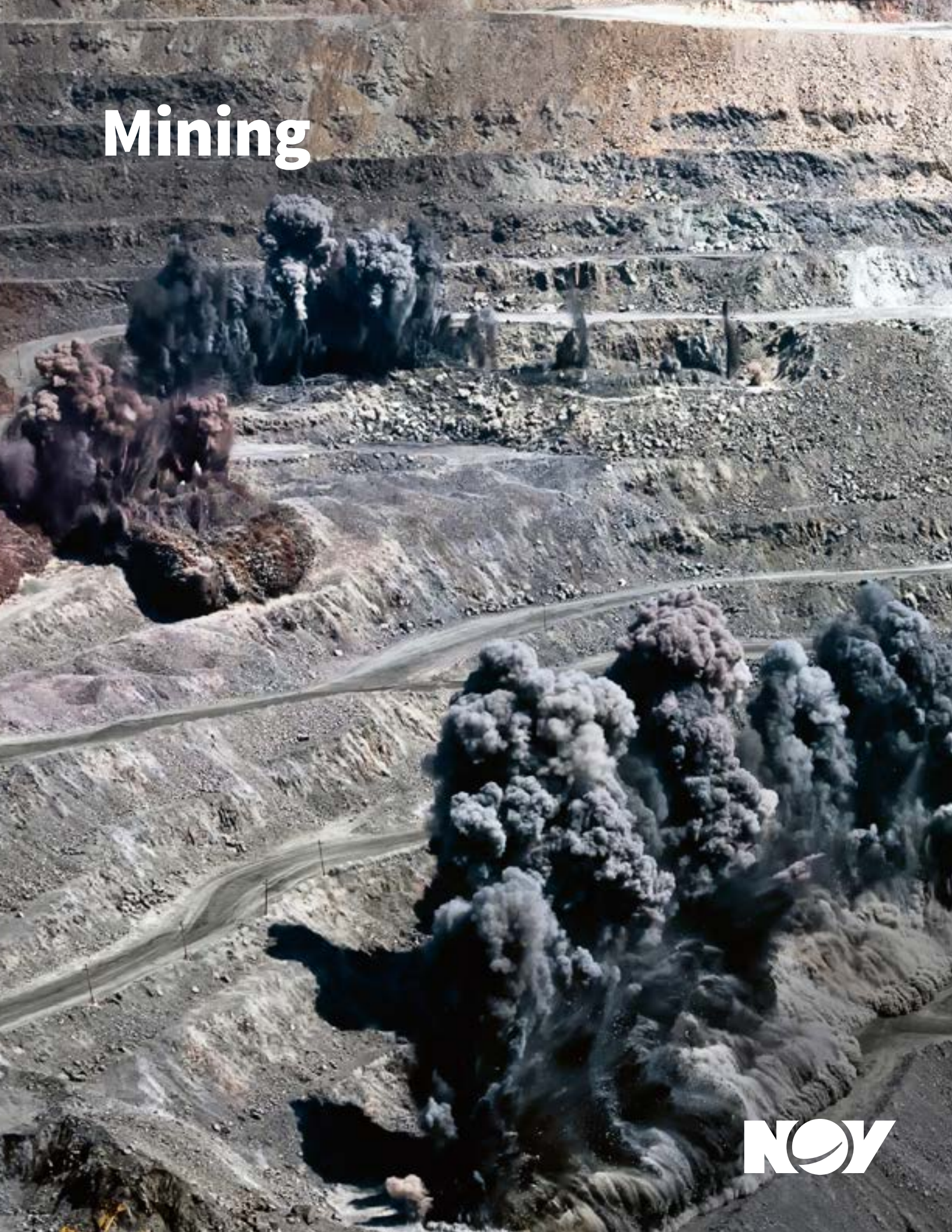

Process and Flow Technologies

We provide process expertise and innovative technology that enhance the efficiency and profitability of your business.

Whether in oil and gas or across various industrial markets, we work with you from the beginning to develop an integrated solution with superior performance—maximizing your project lifecycle economics.

Service expertise drives predictable uptime that is critical to your operation. In every situation, you can rely on us to provide quick and effective support throughout the entire life of your project. Our deep knowledge of your processes ensures you have the latest technology for your application to get the job done right, with trusted products you can depend on – first time, on time, every time.

By consistently providing reliable, technical solutions, we will help your business grow and provide you with the confidence you are looking for in a strategic partner.

Mining

NOV is a leading name in the design, manufacture and supply of progressive cavity pumps, aftermarket components, grinders, screens and packaged fluid transfer solutions worldwide. We have a global manufacturing and distribution network with over 75 years of experience in PC pump design and over 30 years of pump supply into the mining industry. We have combined all of our technology and experience to develop the most reliable dewatering solutions, aimed at keeping your mine dry and production on-line.

With global manufacturing of rotors and stators, sales and service facilities across the globe, we will support you across all aspects of your mine dewatering program. From concept design, through to full turn-key pump station projects, we have the equipment, experience and knowledge to get the job done.

Products & Services

Capital Projects

- Pumps
- Complete systems
- On-site and underground
- Service and maintenance contracts
- Conditioning monitoring

Service Exchange

- Rotors
- Shafts
- Bearing housings
- Bareshaft pumps

Installation and Commission

- Above or below ground
- Qualified personnel
- System design assistance
- Post installation report
- Pre-commissioning advice
- Post-commissioning report
- Technical assistance

Hire

- Progressing cavity pumps
- Starters
- Dewatering rigs
- Process pumps

Aftermarket

Service Exchange

With our National Service Exchange Program we can take away your pump and leave you with a completely rebuilt unit - reducing costly downtime and maintaining peak productivity.

We provide fast response, short lead times plus removal and installation if required. All of our specialist work is carried out using only genuine OEM parts, which are backed by our 12 month nationwide warranty.

Rotor Reclamation

We also offer a rotor reclamation service, returning a worn rotor to near new condition. To achieve maximum performance from our pumps it is critical that the rotor and stator fit is to the tolerances we have taken years to develop.

Universal Parts™ & Spare Parts

We manufacture and supply parts for a variety of PC pumps, all of which have the same warranties and guarantees as the parts for our own products.

Our style of pump is the most efficient dewatering pump on the world market today. When comparing to a large multistage centrifugal and even piston pumps the efficient helical pump will use on average 1/3 of the power consumption required by these other systems.

When reviewing whole life costs of your next pump station, we recommend you take into account:

- power consumption
- average downtime required to do commonly required preventive maintenance and wear component change outs
- plus the cost of components that would be required

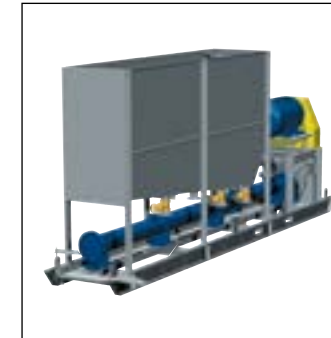

Mining Stations (Standard EZstrip)

- Least whole life options available.
- Suit fixed or mobile situations
- Different configurations available to meet your requirements

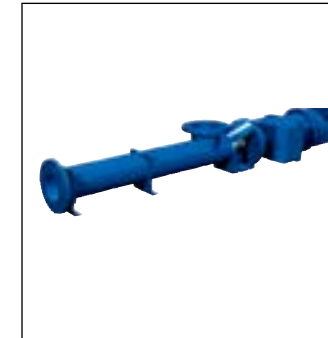

Compact Range

- Flocculants
- Process plants
- General transfer



X Range

- Explosive emulsions
- Truck and surface mounting
- Intrinsically safe flexishaft connections



LF Range

- Metered dosing
- Compact size
- Polymer & flocculant transfer



CP Range

- Compact & versatile
- Oily water separators
- Oil transfer in maintenance bay

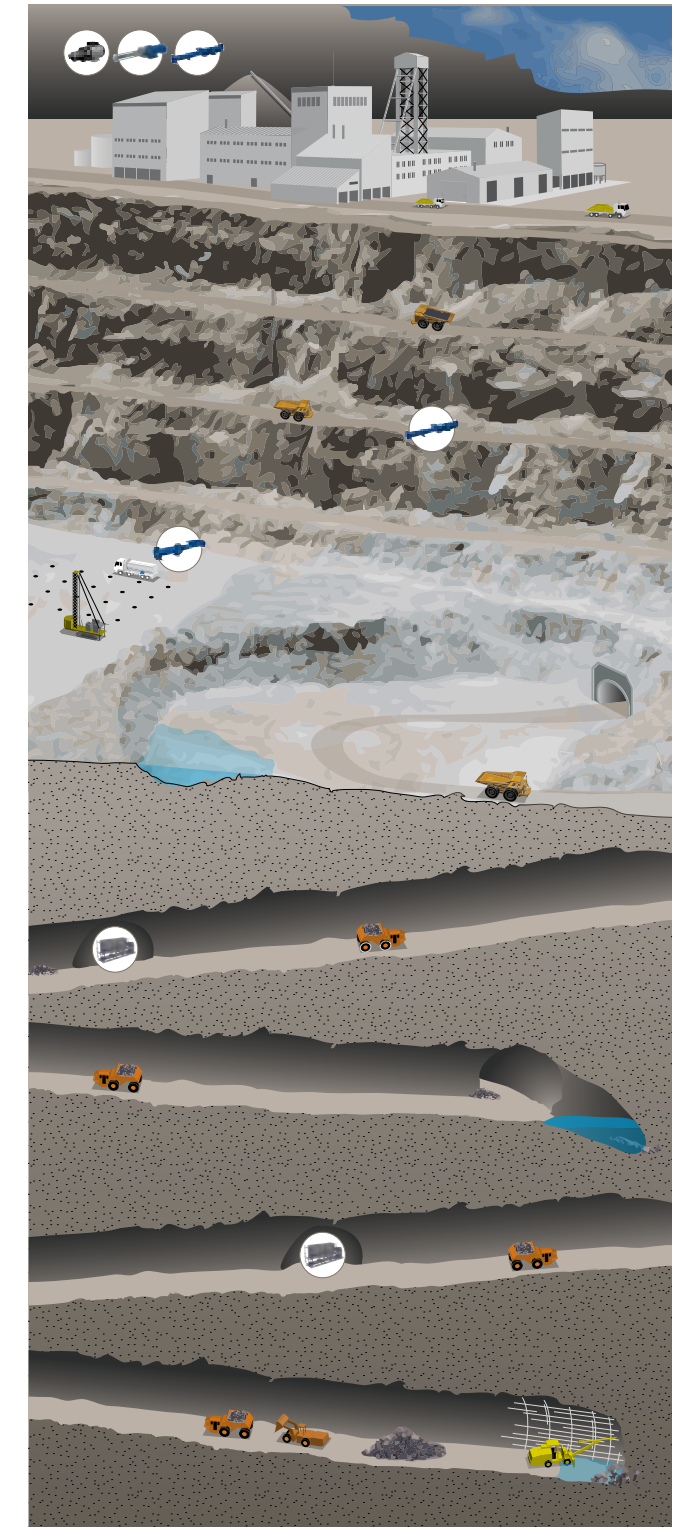

The biggest revolutionary change to mine dewatering in 30 years.

We have taken the challenge out of dewatering by launching the new EZstrip™ mine dewatering range.

We have grown our family of revolutionary maintain-in-place (MIP) solutions, by launching yet another EZstrip™ innovation which is set to transform the mine dewatering industry by significantly reducing down times.

By consulting our customers, we have developed the first progressive cavity pump MIP system that will dramatically improve efficiencies in maintenance and decline interruptions. This new shorter, lighter and lower pumping package provides the solution for mines that require a smaller more compact area to work with.

Features & Benefits

- 6-7 hour maintenance operation changing out rotor and stator reduced to 1 hour.
- Reduction in maintenance time by up to 80%
- Eliminates dismantling lengths
- Optimal safety to maintenance staff i.e. no working at height or under hoppers
- No packed glands, belts or pulleys to maintain
- 3 pumps to fit in same station footprint
- Ex versions available

Technical Specifications

Capacity	up to 20 l/s (317 gpm)
Pressure	up to 36 bar (522 psi)
Temperature	-10°C up to 110°C
Rotors	316 stainless steel
Stator	Nitrile rubber
Models	3 options available

Range Overview

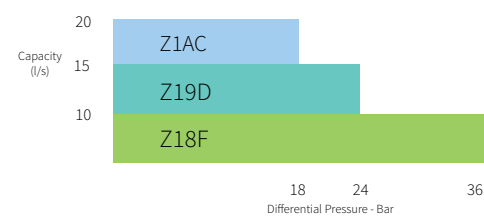

Packaged Dewatering Solution

Our standard EZstrip™ mining pump station assembled and ready to ship from one of our global manufacturing facilities.

1. Rotor

Where capital costs are important, we can offer HCP coated rotors. In all cases, maximum attention is paid to the rotor profile to maximise efficiency and part life. Where arduous environments are causing significant wear on standard product we can offer alternative rotor coatings to increase life.

6. End Cover

All standard pumps are fitted with marine grade Ni-Resist end covers and adaptor flanges to minimise the effects of erosion, corrosion and leakage traditionally found in stainless steel and cast iron end covers.

4. Tie Bars & Anti-Rotation Rings

The use of tie bars with the addition of anti-reversing rings is the recommended solution for elimination of the stator moving when in place.

5. Stator

Made of resilient and abrasion resistant synthetic rubber compound (Nitrile). Dimensional accuracy can be assured through sophisticated co-ordinate measuring technologies.

2. Flexishaft

Our patented flexishaft has been proven over 40 years of service. It is protected with an inert Halar coating and comes with a 5 year warranty.

7. Bearing Housing

The standard mining pump is built with a heavy duty bearing housing, including taper roller bearings and grease packed labyrinth seals. With easy access to multiple greasing points, the bearings can be kept clean and well lubricated to maximise bearings life in extremely harsh often wet environments.

3. Gland

We have again listened to our customer's requirements, all standard pumps now come assembled with Teflon coated braided packing rings.

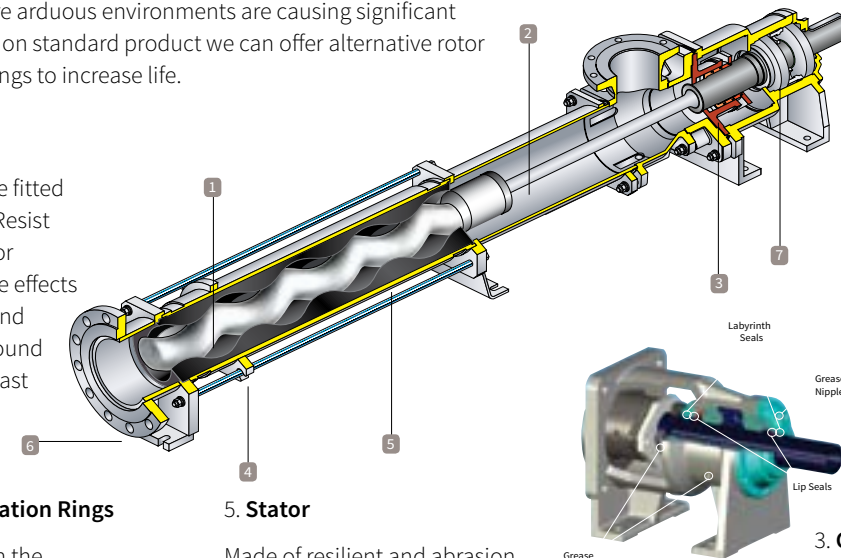

Labyrinth Seals
Grease Nipple
Lip Seals

Grease Nipples

Utilising years of service to the mining industry, we have developed a standardized mine dewatering station in a configuration to suit your needs, be it fixed or mobile situation they are available in bareshaft, motorized or full hopper station with the options shown here.

1. Rotor made of quality 316 S/S, coated with .5mm HCP (diametrically). With years of experience in this field Mono do not recommend a thicker Chrome coating as it can lead to faster degradation of tolerance between rotor and stator.

2. Hopper fully seam welded from 6mm sheet steel, then epoxy painted with quality "International Protective Coatings" product.

3. Flexishaft®, originally designed by Mono pumps 30 years ago, comes with 5 year Warranty.

4. High efficiency 1000V motors with class H insulation and IP66 rating.

5. Pulley guards made to strict Australian standards with no risk to personal injury per OH&S guidelines.

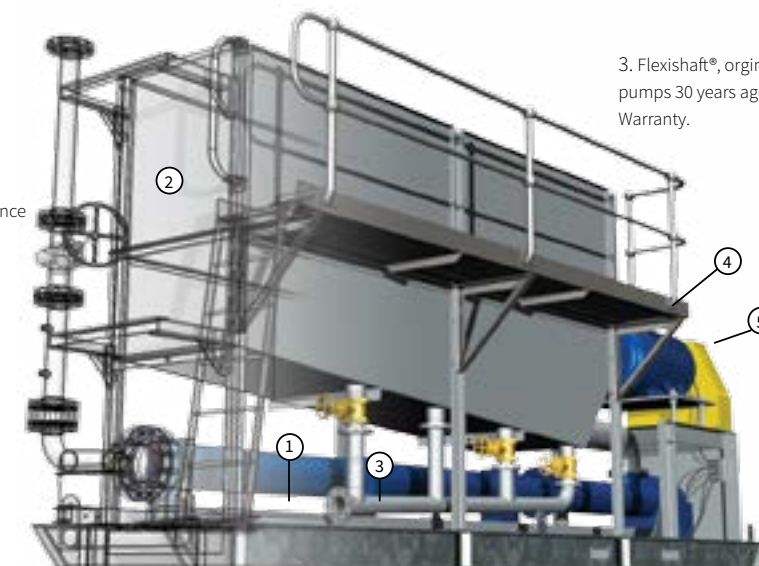

Mission Magnum™ and 2500 Supreme™

The Mission Magnum and 2500 Supreme centrifugal pumps are proven as reliable, heavy duty, low-cost slurry pumps. These pumps are equipped with a heavy duty 2½” shaft protected by a stainless steel shaft sleeve, double row outboard bearings and inboard roller bearings.

Magnum and 2500 Supreme pumps are rated for continuous service in applications up to 200 HP (149 kW). Fluid ends are available in hard iron, stainless steel, aluminum bronze, Magnachrome™, and Supreme Hard™. (Not all sizes are furnished in all materials listed. Call for availability.)

For more information visit www.nov.com or email mining@nov.com.

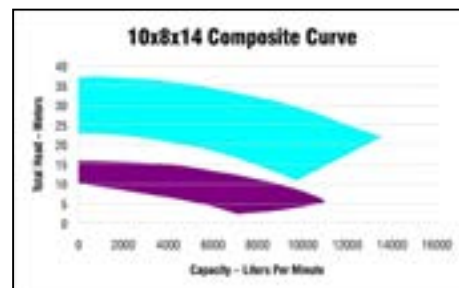
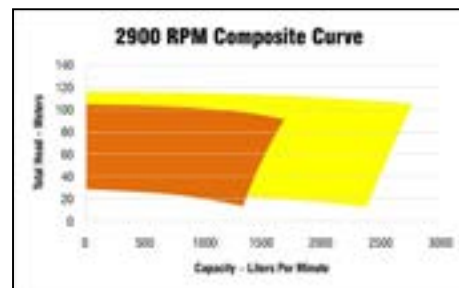
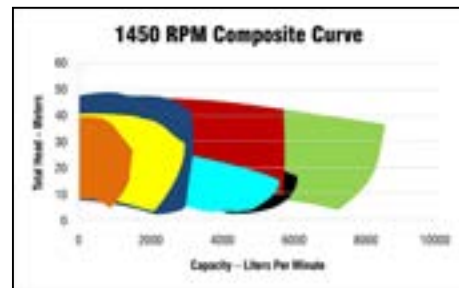
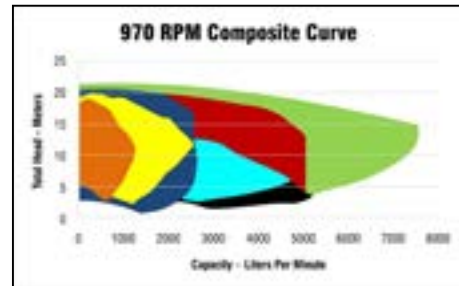

We offer a broad range of reciprocating pumps along with custom fabrication, training, commissioning, and field service to meet customer pumping requirements worldwide.



Continuous Duty Single-Acting

- Input range: 2 – 1200 HP (1 – 895 kW)
- Pressure: up to 6,175 PSI (42,575 kPa)

Continuous Duty Double-Acting

- Input range: 9 – 182 kW (12 – 244 HP)
- Pressure: up to 12,411 kPa (1,800 PSI)

Pumps and Services

Our line of premium pump expendables includes tungsten carbide plungers, spherical valve assemblies, and premium plunger packing.

- High mechanical efficiency (90%) and high volumetric efficiency (95%) regardless of operating point
- Can be adapted to pump fluids with entrained sand particles or slurries
- Constant delivered flow independent of system pressure
- Easily field maintained and repaired
- Can be equipped with a diverse range of fluid-end materials

Fluid End Expendables

Our line of premium pump expendables includes tungsten carbide plungers, spherical valve assemblies, and premium plunger packing.

Features and Benefits

- High mechanical efficiency (90%) and high volumetric efficiency (95%) regardless of operating point
- Can be adapted to pump fluids with entrained sand particles or slurries
- Constant delivered flow independent of system pressure
- Easily field maintained and repaired
- Can be equipped with a diverse range of fluid-end materials

Accessories

We also offer a wide range of relief valves and pulsation dampeners in sizes of 100, 300, 600, 900, and 1200 cubic inches.

Multistage Surface Pump (MSP)

Our MSP unit is a cost effective, low maintenance solution for high volume, high pressure fluid** movement.

- Max head 247 bar, max flow 82 l/s
- Thrust chamber is field repairable with no need to remove pump or motor.
- Mechanical seal can be replaced in situ in 1 hour
- Minimal downtime for scheduled maintenance in comparison to similar units.

**Fluid being pumped cannot contain large solids, recommend filtration prior to pump.



Typical Mining Applications

- Single lift (high head) dewatering of unsettled (dirty) mine water
- High concentration slurry pipeline pumps
- Tailings disposal
- Filter press pumps
- Longwall (hydraulic) coal mining

Filtration

We also offer a range of Reverse Osmosis, Hydro Cyclones, solids handling & filtration control solutions to suit your needs in this ever increasing market place.

National Oilwell Varco has produced this brochure for general information only, and it is not intended for design purposes. Although every effort has been made to maintain the accuracy and reliability of its contents, National Oilwell Varco in no way assumes responsibility for liability for any loss, damage or injury resulting from the use of information and data herein. All applications for the material described are at the user's risk and are the user's responsibility.

Corporate Headquarters
7909 Parkwood Circle Drive
Houston, Texas 77036
USA

Process and Flow Technologies
2500 City West Blvd., Suite 2000
Houston, Texas 77042
USA

