

P/N 20090035

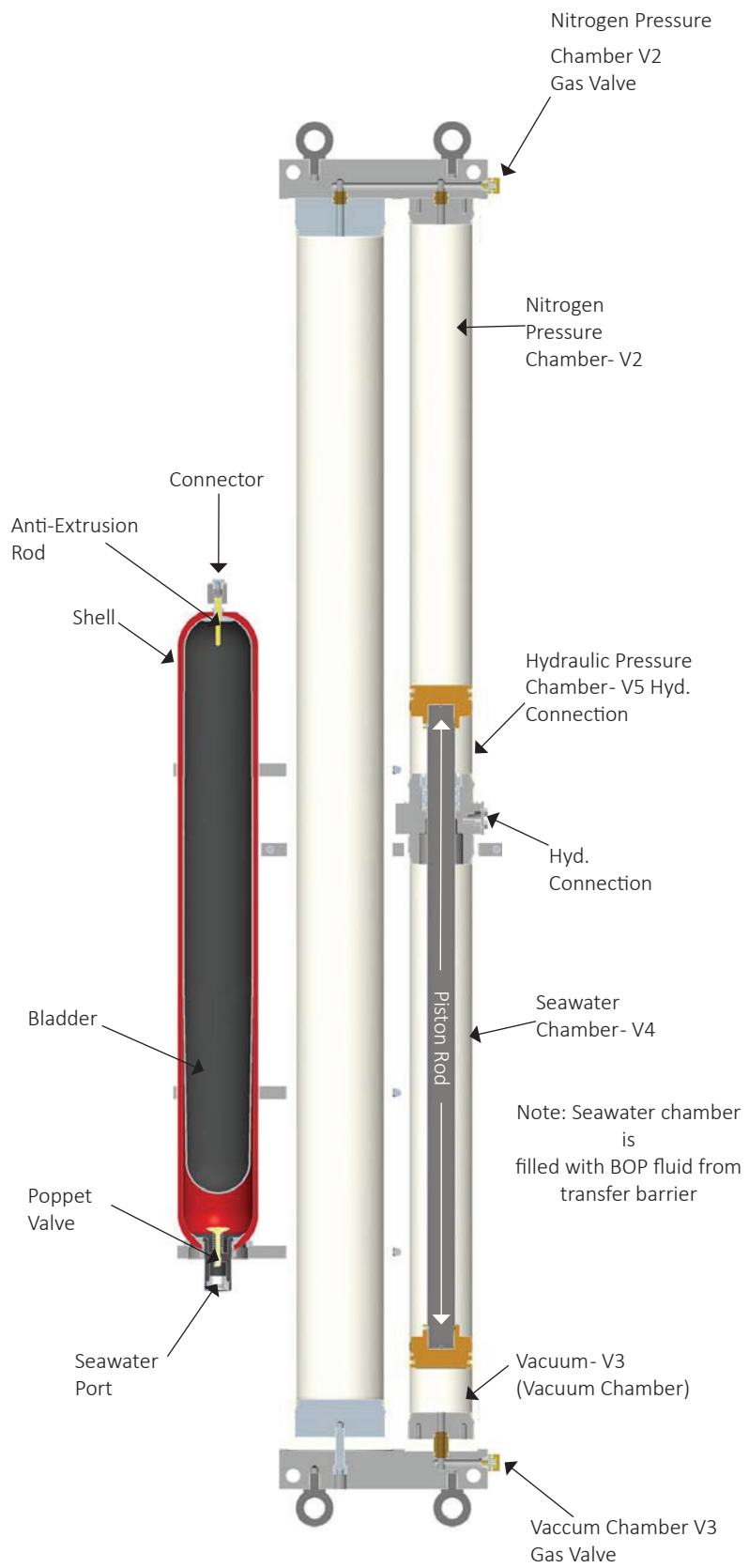

Specifications:

P/N	V5 Vol.	V1 Vol.	V2 Vol. (Max)	Height	Width	Depth	Weight
200900 35	7.9 Gal (30 liters)	43.8 Gal (166 liters)	10 Gal (38 liters)	150.24" (3,816.1 mm)	25.5" (647.7 mm) 11.9" (302.3mm)	14.12" (358.6 mm)	3,995 lb (1,812 bar)
10641709-001	17 Gal (64.35 liters)	116.9 Gal (442.5 liters)	19.95 (75.5 liters)	150" (3,181 mm)	34" (863.6 mm)	19.5" (495.3 mm)	7,208 lb (3,269 kg)
10641709-002	20.6 Gal (77.98 liters)	138.1 Gal (522.8 liters)	24.2 Gal (91.6 liters)	175" (4,445 mm)	34" (863.6 mm)	19.5" (495.3 mm)	7,984 lb (3,621 kg)
10641709-004	25.8 Gal (97.66 liters)	167.9 Gal (635.6 liters)	30.3 Gal (114.7 liters)	210" (5,334 mm)	34" (863.6 mm)	19.5" (495.3 mm)	9,077 lb (4,117 kg)
10641709-003	28 Gal (105.99 liters)	180.8 Gal (684.4 liters)	32.8 Gal (124.2 liters)	225" (5,715 mm)	34" (863.6 mm)	19.5" (495.3 mm)	9,545 lb (4,329 kg)

Configuration:

(Transfer Barrier can be mounted separately if desired)

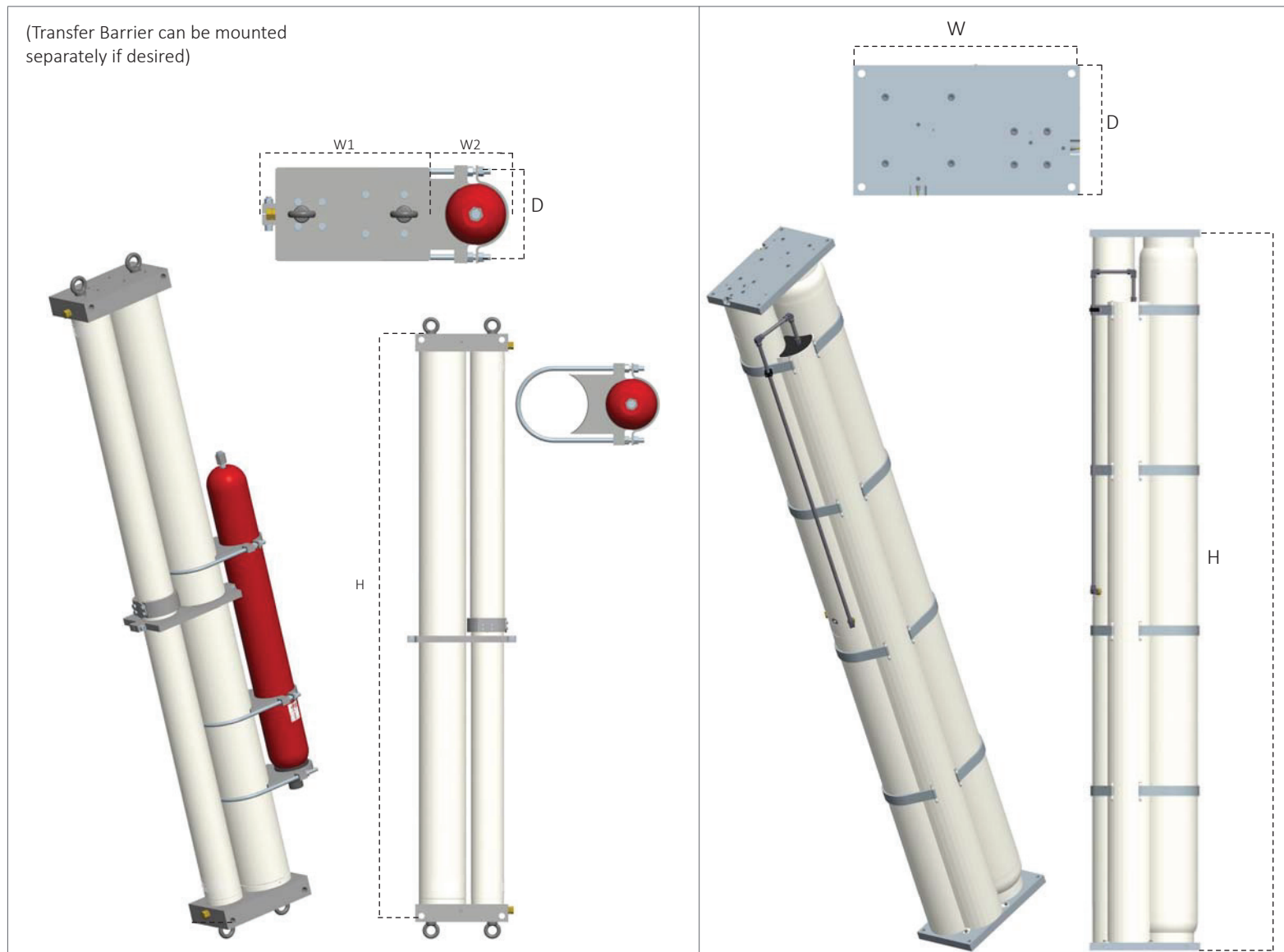

P/N 10641709-003

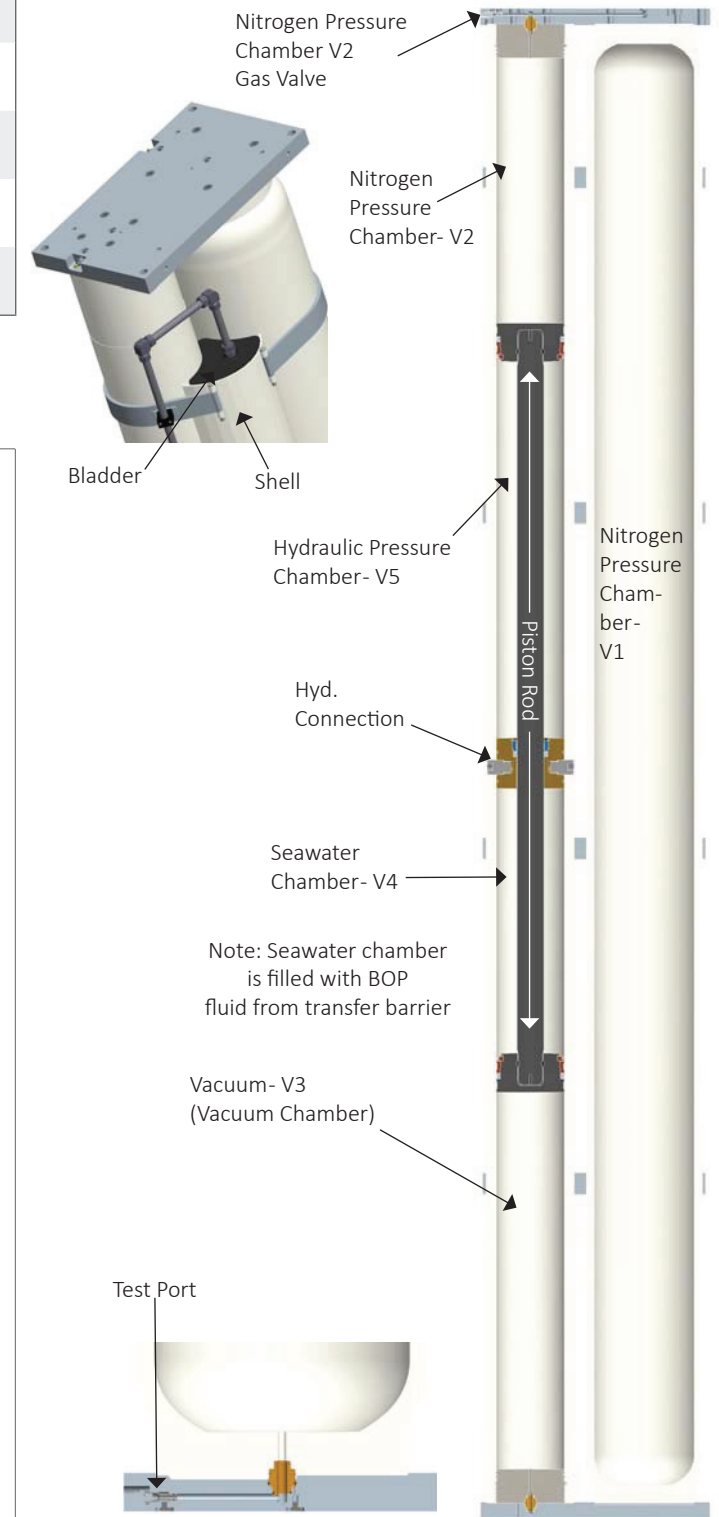

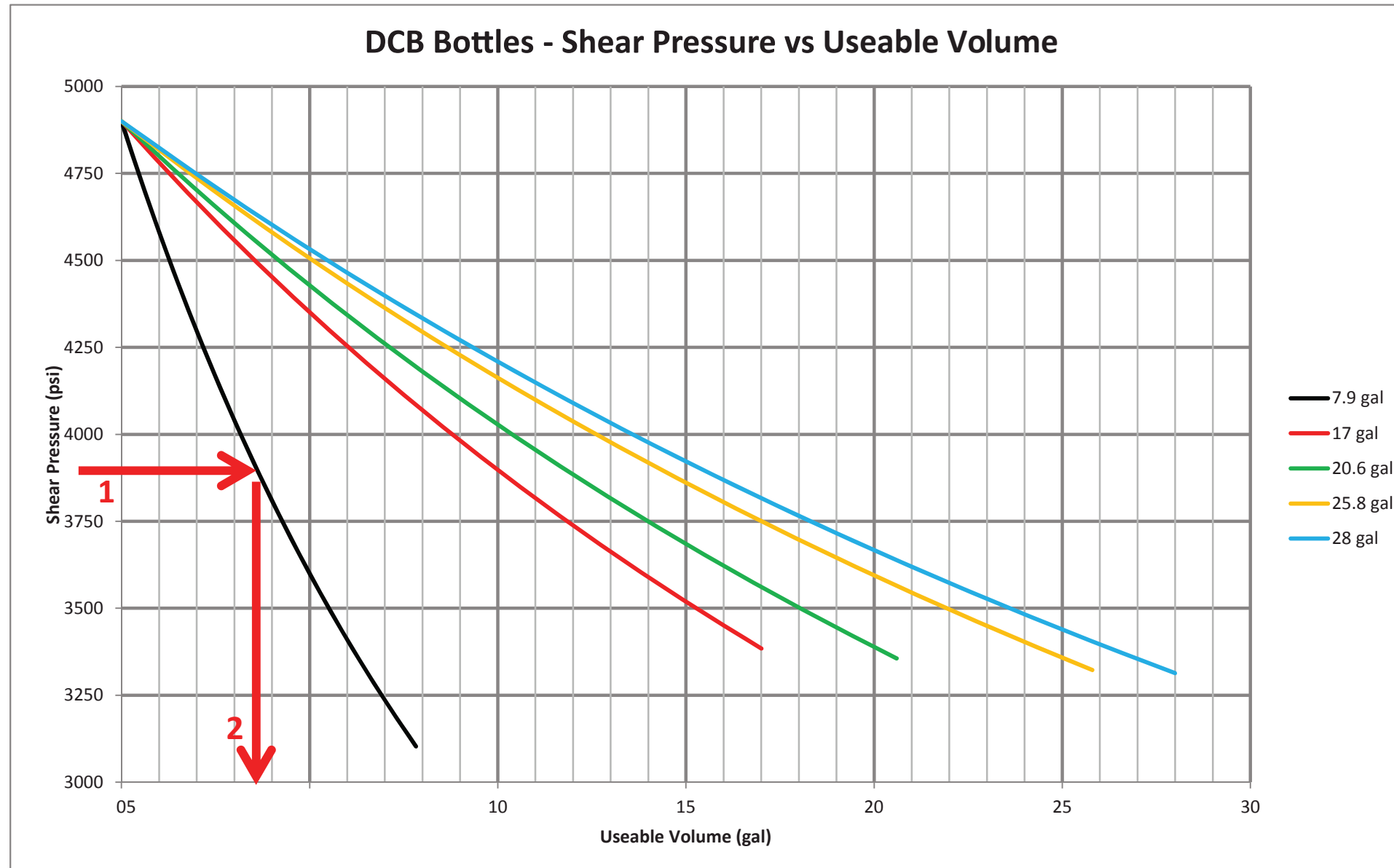

Operation:

Today's designed operating environment for stack mounted accumulators is challenging. Design criteria include 12,000 ft water depths, temperatures as low as 32°F with surface temperatures of 120°F, rapid discharge (adiabatic), as well as higher minimum system pressures. All of these things add up to a large number of bottles on a lower BOP stack.

It is not uncommon to see as many as 126 accumulator bottles on a lower BOP Stack, 98 of which are dedicated to the shear system alone. This adds weight to the overall assembly, increases maintenance requirements, and decreases stack equipment access.

By using the water column pressure and mechanically boosting the hydraulic pressure, a Depth Compensated Accumulator has reduced the total number of stack mounted shear circuit bottles dramatically.

Functionality:

This system is comprised of a double-piston accumulator. The two pistons are connected by a piston rod. This creates five separate chambers within the DCB, plus the transfer barrier.

The first two chambers (V1 and V2) contain a Nitrogen precharge acting against one piston.

The third chamber (V3) is a vacuum that acts against the other piston.

The fourth chamber (V4) is filled with BOP fluid from the transfer barrier. The transfer barrier is open to ambient seawater pressure on one end and forces more fluid into V4 as depth increases.

The fifth chamber (V5) contains the hydraulic fluid.

The result is 100% usable hydraulic fluid while subsea.

Example:

Estimating the number of bottles required:

1- On the vertical axis, find the required Shear Pressure (Including the effects of Mud Weight and Water Depth) and intersect with the curve for DCB bottle type.

(Example : 3900 psi, 7.9 Gal DCB)

2- Draw a line down from the point of intersection to the horizontal axis of the chart and read useable volume for one bottle.

(Example : 3.6 gal)

3- Multiply the required operator volume by 1.1 (API 16D Volume Design factor) to obtain the total required volume.

(Example: 18'-15M NXT 22" Operator, closing volume = 37.3 gal, required volume = 37.3 x 1.1 = 41.03 gal)

4- Divide the required volume by the useable volume for one bottle to obtain the required number of bottles. (Round up to the next whole number.)

(Example: 41.03/3.6 = 11.4, round up to 12 bottles)

Note: This is only an estimate. Contact NOV Pressure Control Engineering for certified calculations.

Equation:

$$\frac{\text{Required Operational Volume} \times 1.1}{\text{Volume Used Per Bottle}} = \text{Number of Bottles Required (Round Up)}$$